

ITEM NO.	QTY.	PART NO.	DESCRIPTION
1	2	08490	BEARING
2	1	19308	SHAFT
3	1	06837	RET. RING
4	1	05126	RET. RING
5	1	04432	WOODRUFF KEY
6	1	18652	SEAL
7	1	10944	CAM
8	1	10615	IMPELLER
9	1	21120	COVER
10	4	00343	LOCK WASHER
11	1	19995	Cam Screw
12	1	19996	CAM WASHER
13	1	12231	O-RING (Nitrile)
14	1	23791	BODY
15	4	2220-0099	BOLT
16	1	23854	ADAPTER

NOTATIONS:  
1. STAMP P110 AND DATE CODE ON BACK COVER.

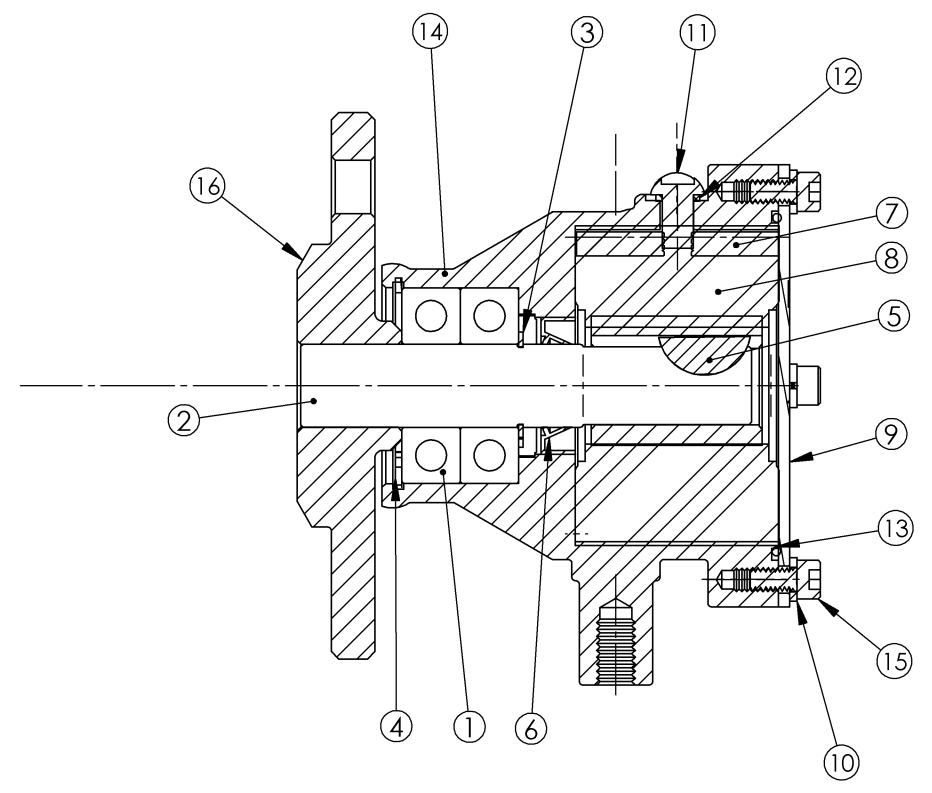
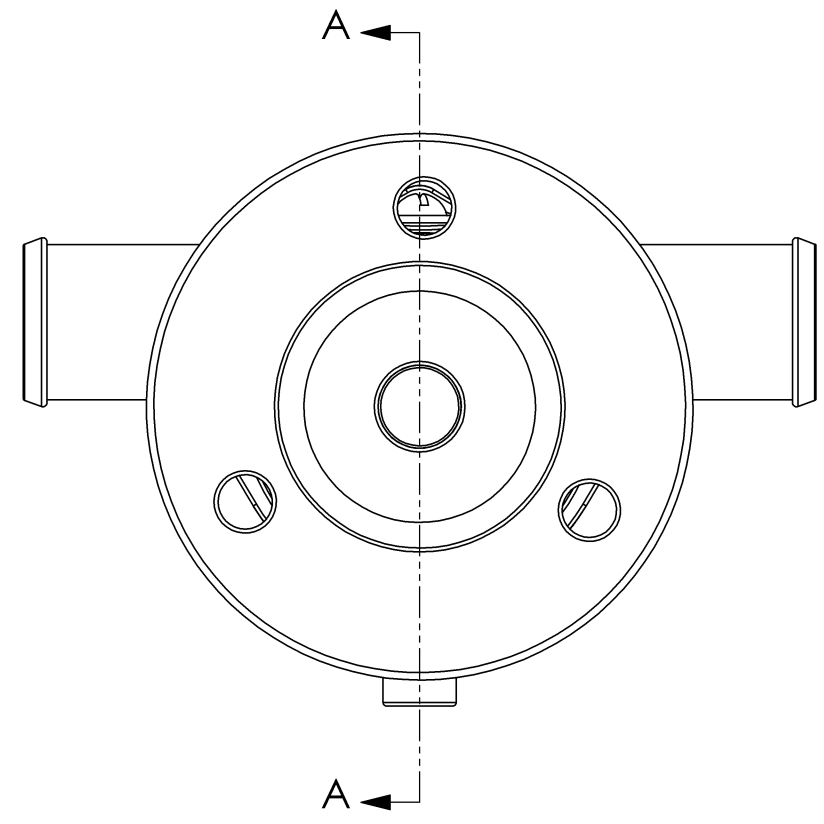

SECTION A-A

<p><b>Hypro Corporation</b> A WICOR COMPANY 375 Fifth Avenue NW, New Brighton, MN 55112, (651) 766-6300 DRAWING BASED ON ASME Y14.5M-1994</p>				EXPERIMENTAL PART NO.	REV.				
				<p>TOLERANCES UNLESS OTHERWISE SPECIFIED (+ OR -) INCHES</p> <table border="1"> <tr> <td>ANGLES (MACH): 5°</td> <td rowspan="3">SURFACE FINISH 125 MAX</td> </tr> <tr> <td>FRACT. (MACH): 1/64</td> </tr> <tr> <td>DECIMAL .XX: .01</td> </tr> <tr> <td>DECIMAL .XXX: .004</td> <td></td> </tr> </table>		ANGLES (MACH): 5°	SURFACE FINISH 125 MAX	FRACT. (MACH): 1/64	DECIMAL .XX: .01
ANGLES (MACH): 5°	SURFACE FINISH 125 MAX								
FRACT. (MACH): 1/64									
DECIMAL .XX: .01									
DECIMAL .XXX: .004									
<p>THIRD ANGLE PROJECTION DO NOT SCALE PRINT</p>				<p>DWG BY: DV DATE: 6-21-00</p>					
<p>SURFACE TREATMENT SCALE FULL</p>				<p>CHECKED BY: DATE:</p>					
<p>HEAT TREATMENT</p>				<p>THIS DRAWING IS THE PROPERTY OF HYPRO AND WITHOUT WRITTEN AUTHORIZATION, MUST NOT BE COPIED OR COMMUNICATED.</p>					
<p>MATERIAL</p>				<p>PART NUMBER P110</p>					
<p>REV. ECN REVISION DESCRIPTION CHKD DATE</p>				<p>REV. B</p>					
<p>B 4402 REINSTATE FOR PRODUCTION dv 9-8-04</p>									
<p>A E1109 RELEASE FOR PRODUCTION. DV 9-14-00</p>									
<p>FORM FM-EN-022 REV. ...</p>									