



OBERDORFER
by Gardner Denver

BRONZE RUBBER IMPELLER PUMP
UNIVERSAL/KUBOTA ENGINE MOUNT

N202M Series

N202M/N202M-03/
N202M-07



N202M-15/N202M-16

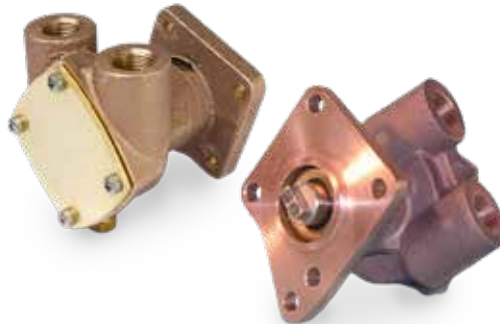

N202M-11



N202M-17



N202M-17P



N202M-21



N202M-23



N202M-24



Features

- Rugged simplicity
- Corrosion Resistant
- Convenient drain plug
- Flange mounting
- Slotted shaft drive or male tang drive
- 2 separate seals: main pump and flange mounting
- “Vertical” direction in & out ports
- High chrome nickel stainless steel shaft
- Impeller easily replaced
- Machined in cam
- See N202M-837 for additional details

Rotation

Direction of shaft rotation determines inlet and outlet ports (see line dimension drawing). Prior to installation, rotate the pump manually in direction of rotation to set flexible blades in direction desired.

Do Not Run Dry

Rubber impellers generate high rubbing friction unless lubricated by liquid pumped. Lack of liquid will cause impeller to degrade rapidly.

PERFORMANCE CAPACITY, WATER 70°F

**N202M FULL CAM PERFORMANCE
NEOPRENE IMPELLER**

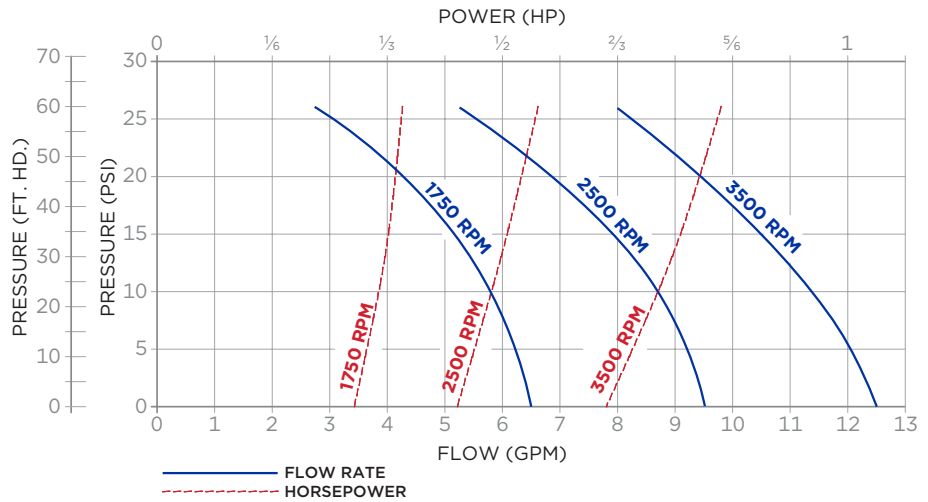

**N202M-03 HALF CAM PERFORMANCE
NEOPRENE IMPELLER**

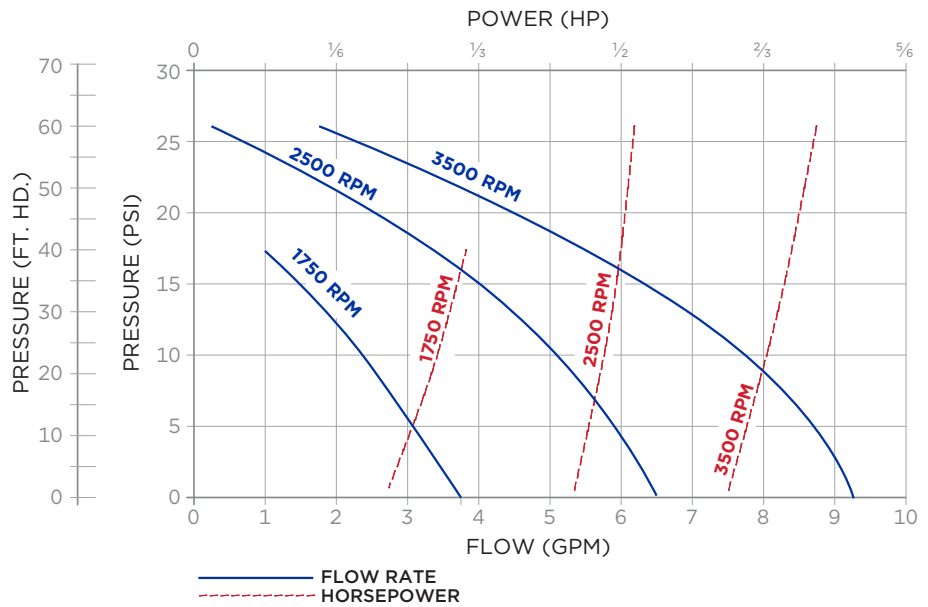

Liquids & Temperature

Liquids compatible with neoprene can be pumped including fresh and salt water solutions and mild chemicals. Do not pump gasoline, severe solvents or acids. When possible flush pump with fresh water after each usage. NBR impellers can handle oil contaminated water and kerosene, although it will reduce impeller service life. Extremes of cold and heat will affect impeller life. Limits of 40 to 140°F should be observed. Do not allow liquid in pump to freeze. Drain pump by removing drain plug provided, located at bottom of pump body. Use methyl alcohol based anti-freeze compounds such as Zerex, Shell Sone, Pyro Permanent, Permagard, Dowgard.

Suction Lift

On initial start-up pump must be primed to prevent dry-running of the impeller. Suction lift of 15 feet is possible when impeller is wet and pump fully primed. Suction lines must be air tight in order for pump to self prime.

DESIGN SPECS

MODEL	PORTS		CAM	FLANGE	PILOT	SHAFT	DESIGNED FOR	REFERENCE
	SIZE	ORIENTATION						
N202M	1/2 FNPT	Vertical	FULL	2 BOLT	NONE	SLOT		
N202M-03	3/8 FNPT	Vertical	HALF	2 BOLT	NONE	SLOT	Atomic 4 Gas and Diesel Marine Engines	295625/ 15098
N202M-07	3/8 FNPT	Vertical	FULL	2 BOLT	NONE	SLOT	Atomic 4 Gas and Diesel Marine Engines	299805
N202M-11	1" HOSE	Vertical	FULL	4 BOLT	MALE	TANG	Onan -Kubota	132-0277
N202M-15	3/8 FNPT	Vertical	FULL	5 BOLT	MALE	TANG	Universal Series - Super Mini Kubota Diesel	301357
N202M-16	1/2 FNPT	Vertical	FULL	5 BOLT	MALE	TANG	Universal Series - Super Mini Kubota Diesel	
N202M-17	3/4 x 5/8 FNPT	135°	FULL	3 BOLT	MALE	TANG	Kubota 05 Series - PTO	
N202M-17P	3/4 x 5/8 FNPT	135°	FULL	2 BOLT	MALE	TANG	Kubota V1505 (behind injection pump)	
N202M-21	1/2 FNPT	Vertical	FULL	4 BOLT	MALE	ROUND	PCI SGNCS Caterpillar Diesel - Pulley	582105
N202M-23	1/2 FNPT	Vertical	FULL	2 BOLT	MALE	TANG	Kubota 05 Series - Tach Mount	
N202M-24	1/2 FNPT	Vertical	FULL	3 BOLT	MALE	TANG	Kubota D902-E3B Side PTO	

KUBOTA-ONAN ENGINE DATA

PUMP	MODEL	HP	CYLINDERS	DISPLACEMENT	
				CU INCH	CC
N202M-11	8.0 MDKD-A				
	8.0 MDKD-L				
	4.0 MDKC-A				
	4.0 MDKC-L				
	6.5 MDKD-P				
	6.5 MDKD-Z				
	3.5 MDKC-P				
	3.5 MDKC-Z				
N202M-16	Z482E	13.5	2	29.2	479
	D722E	20.5	3	44	719
	V1903E	42	4	113	1857
	V2203E	49.5	4	134	2197
N202M-17 N020M-23	D0905E	24	3	55	898
	D1005E	24	3	61	1001
	D1105E	25	3	68.5	1123
	V1305E	30	4	82	1335
	V1505E	34	4	91	1496
N202M-17P	V1505	34	4	91	1496
N202M-24	D902-E3B	21.6	3	55	898

WESTERBEKE/UNIVERSAL ENGINE DATA

PUMP	MODEL	HP	CYLINDERS	BLOCK
N202M-03	Atomic 4	30	4	
	Kermath	20	4	
	Westerbeke Four-60 Marine Diesel	15	4	
N202M-07	M-15	11	2	Z-500
	Atomic 5411	11	2	
N202M-15	M-12	10	2	Z-400
	M-18	14	2	Z-600
	M-25XP	23	3	D-950
	M-30	24	3	D-1101
	M-30	24	3	D-1102
	M-50	44	2	V-1902

PARTS LIST: N202M, N202M-03, N202M-07, N202M-15, N202M-16

ITEM NO.	DESCRIPTION	MODEL NO.					QTY.
		N202M	N202M-03	N202M-07	N202M-15	N202M-16	
1	Screw	5385	5385	5385	5385	5385	4
2	Cover	6597B	6597B	6597B	6597B	6597B	1
3	O-Ring	9797-034	9797-034	9797-034	9797-034	9797-034	1
4	Snap Ring	5373	5373	5373	5373	5373	1
5	Impeller	6593	6593	6593	6593	6593	1
6	Shaft	6598	6598	6598	8767	8767	1
7	Body	6595-1	6892-2	6892-1	8920-1	9879-1	1
8	Lip Seal	5463	5463	5463	5463	5463	2
9	Plug	6600	6600	6600	6600	6600	1
10	Grease Fitting	5390	5390	5390	N/A	N/A	1
11	Washer	N/A	N/A	N/A	9647	9647	2
12	Bearing	N/A	N/A	N/A	5091	5091	1
13	Tag	7736	7736	7736	7736	7736	1

REPAIR KIT	
N202M	
N202M-03	10725
N202M-07	
N202M-15	
N202M-16	11691
Items Included	3, 4, 5, 8 & 12

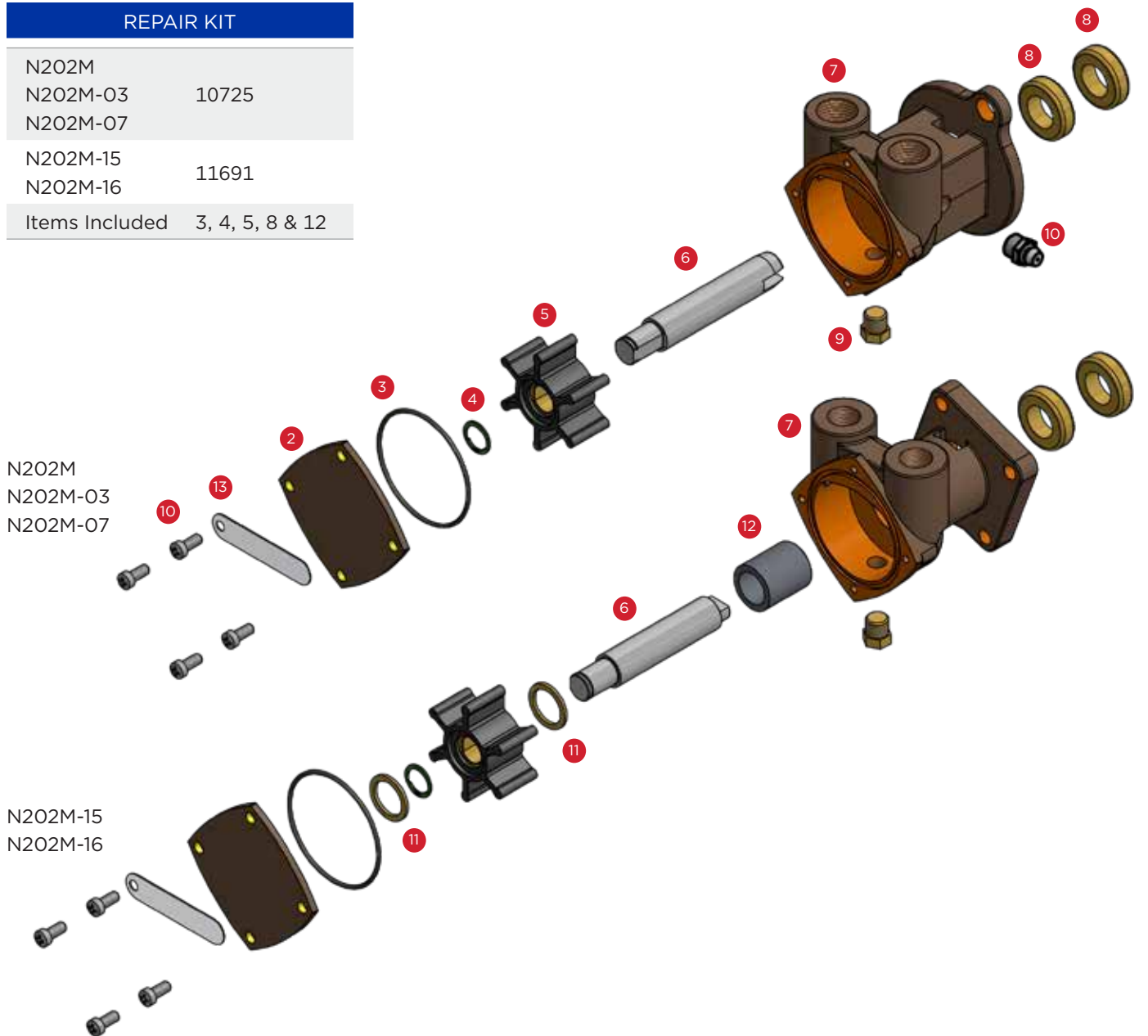

PARTS LIST: N202M-11, N202M-17, N202M-17P

ITEM NO.	DESCRIPTION	MODEL NO.			QTY.
		N202M-11	N202M-17	N202M-17P	
1	Screw	8907-1	5385	5385	4
2	Cover	6597B	6597B	6597B	1
3	O-Ring	9797-034	9797-034	9797-034	1
4	Washer	8927	8927	8927	1
5	Impeller	6593	6593	6593	1
6	Shaft	8870	8870	8870	1
7	Body	8869-02	9887-2	9887-3	1
8	Seal Assy	32592	32592	32592	1
9	Snap Ring	5373	5373	5373	3
10	Snap Ring	7639	7639	7639	1
11	Lip Seal	8868	8868	8868	2
12	Ball Bearing	5847	5847	5847	1
13	Tag	7736	7736	7736	1
14	Slinger	8874	8874	8874	1
15	Snap Ring	7557	7557	7557	1
16	Pipe Plug	N/A	7443	7443	1

REPAIR KIT	
N202M-11	11679
N202M-17 N202M-17P	N/A
Items Included	1, 3, 5, 6, 8, 9, 10, 11, 12, 14 & 15

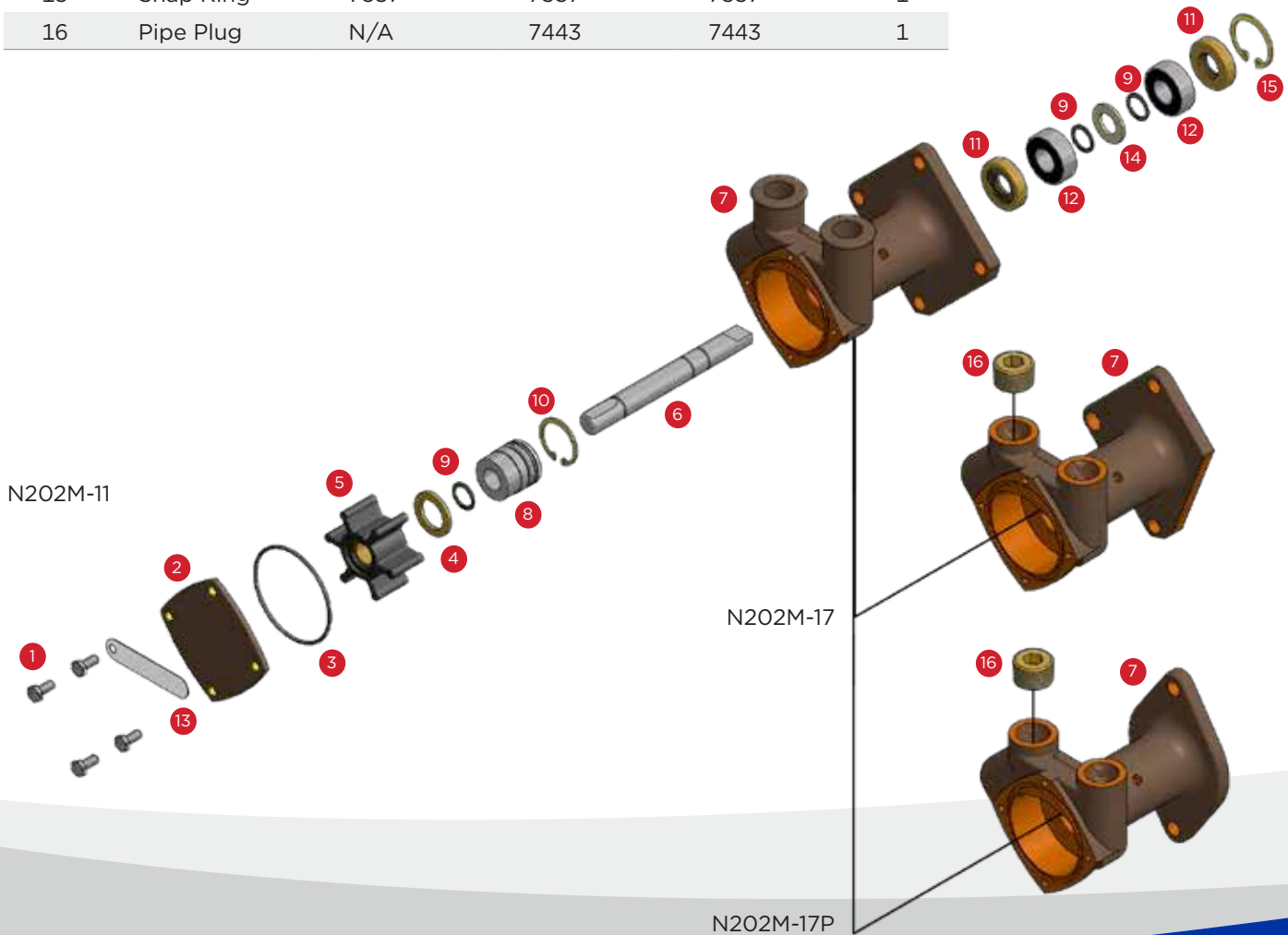

PARTS LIST: N202M-23, N202M-24

ITEM NO.	DESCRIPTION	MODEL NO.		QTY.
		N202M-23	N202M-24	
1	Screw	5385	5385	4
2	Cover	6597B	6597B	1
3	O-Ring	9797-034	9797-034	1
4	Washer	9647	9647	2
5	Impeller	6593	6593	1
6	Shaft	8767	8767	1
7	Body	2196	3458	1
8	Bearing	5091	5091	1
9	Snap Ring	5373	5373	1
10	Lip Seal	5463	5463	2
11	Pipe Plug	6600	N/A	2
12	Tag	7736	7736	1

REPAIR KIT	
N202M-23	11691
N202M-24	
Items Included	3, 5, 8, 9, & 10

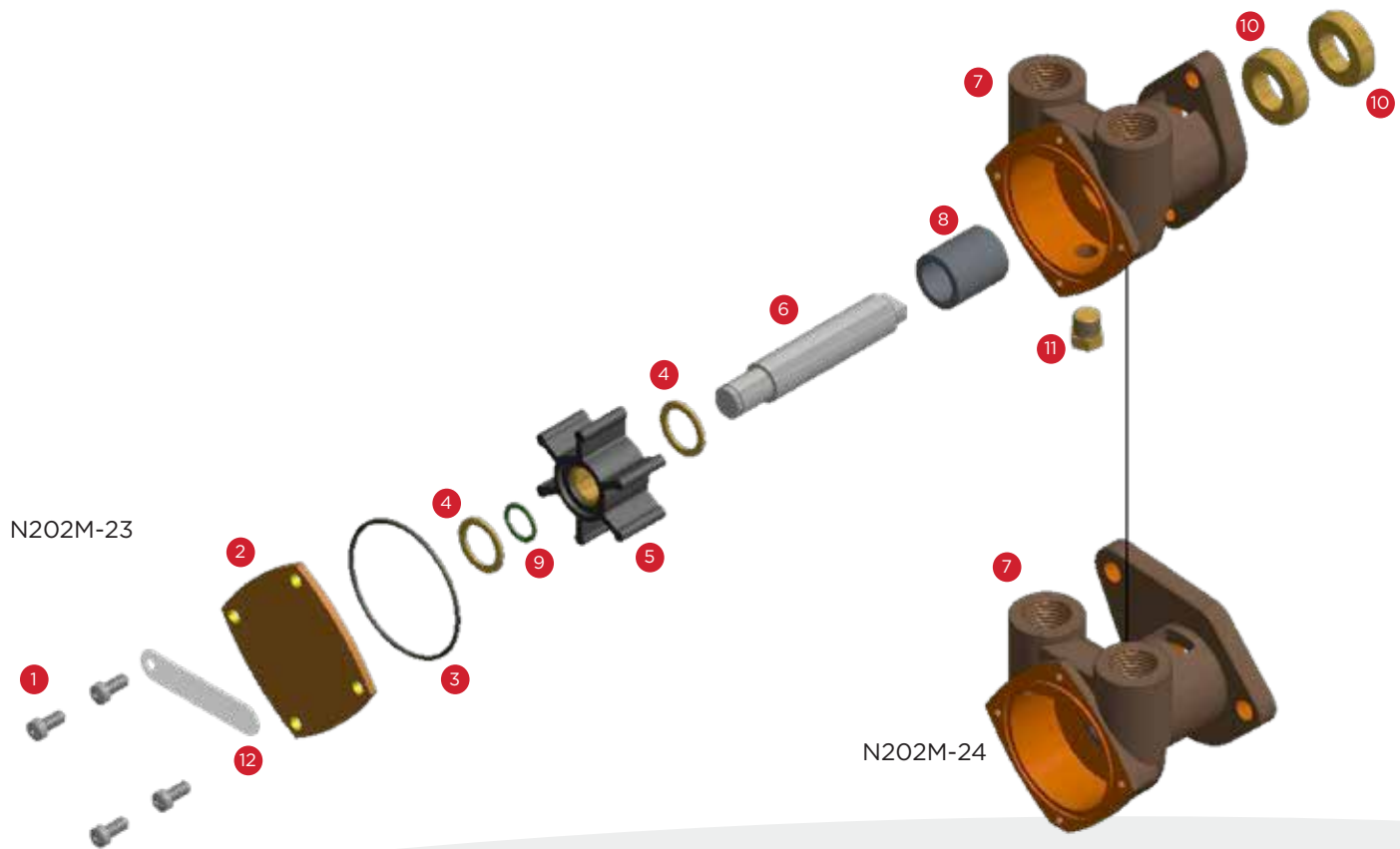

PARTS LIST: N202M-21

ITEM NO.	DESCRIPTION	MODEL NO. N202M-23	QTY.
1	Screw	5385	4
2	Cover	6597B	1
3	O-Ring	9797-034	1
4	Washer	8927	1
5	Impeller	6593	1
6	Shaft & Bearing	2796	1
7	Body	9275-01	1
8	Seal Assembly	32592	1
9	Snap Ring	5373	1
10	Snap Ring	5741	1

REPAIR KIT	
N202M-21	12198
Items Included	1, 3, 5, 6, 8, 9, & 10

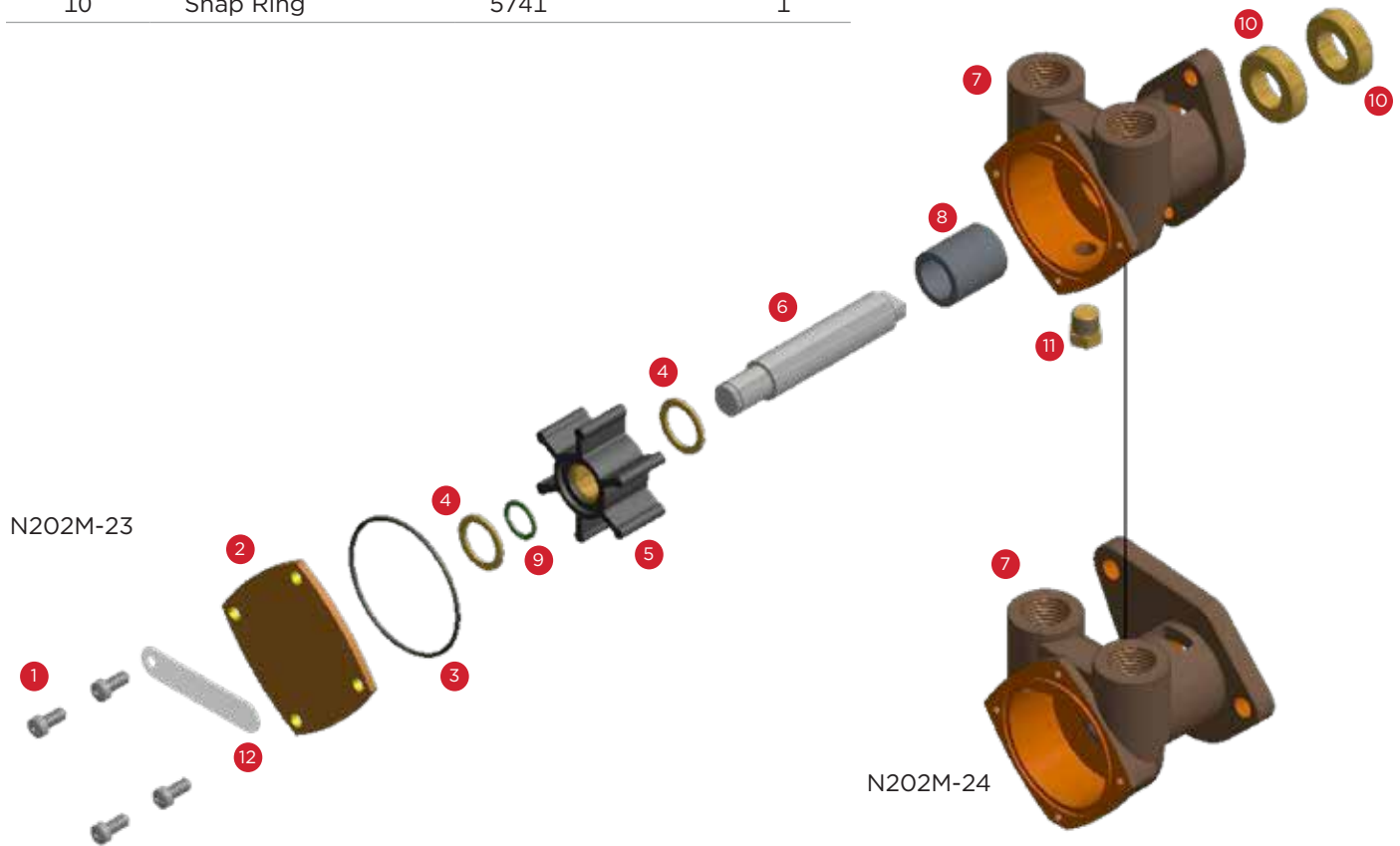

DIMENSIONS

N202M, N202M-03, N202M-07

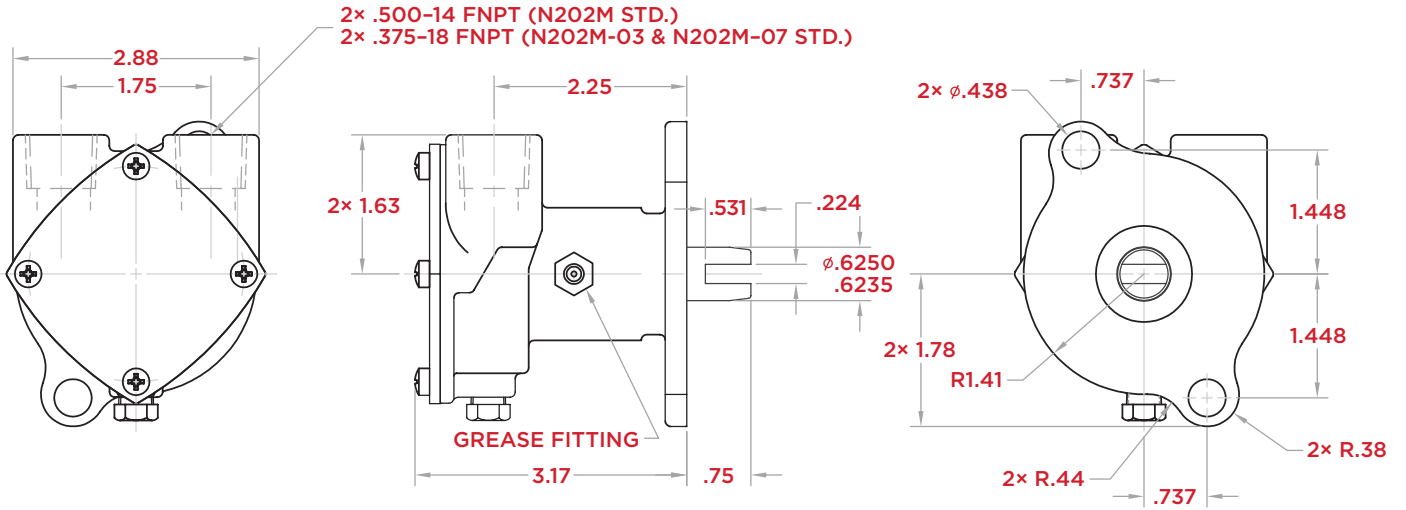

N202M-11

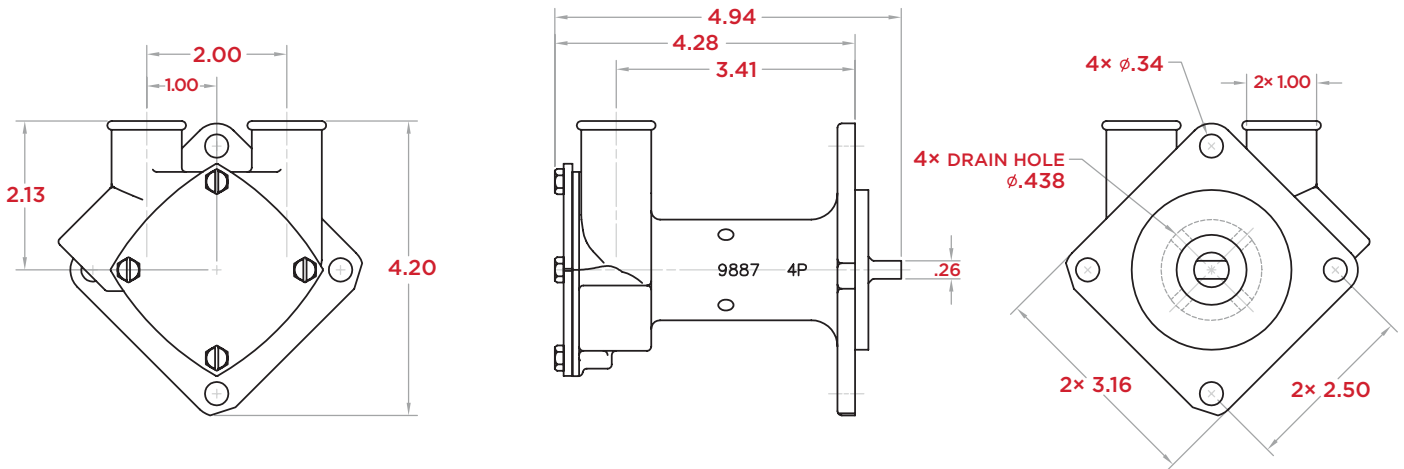

DIMENSIONS

N202M-15, N292M-16

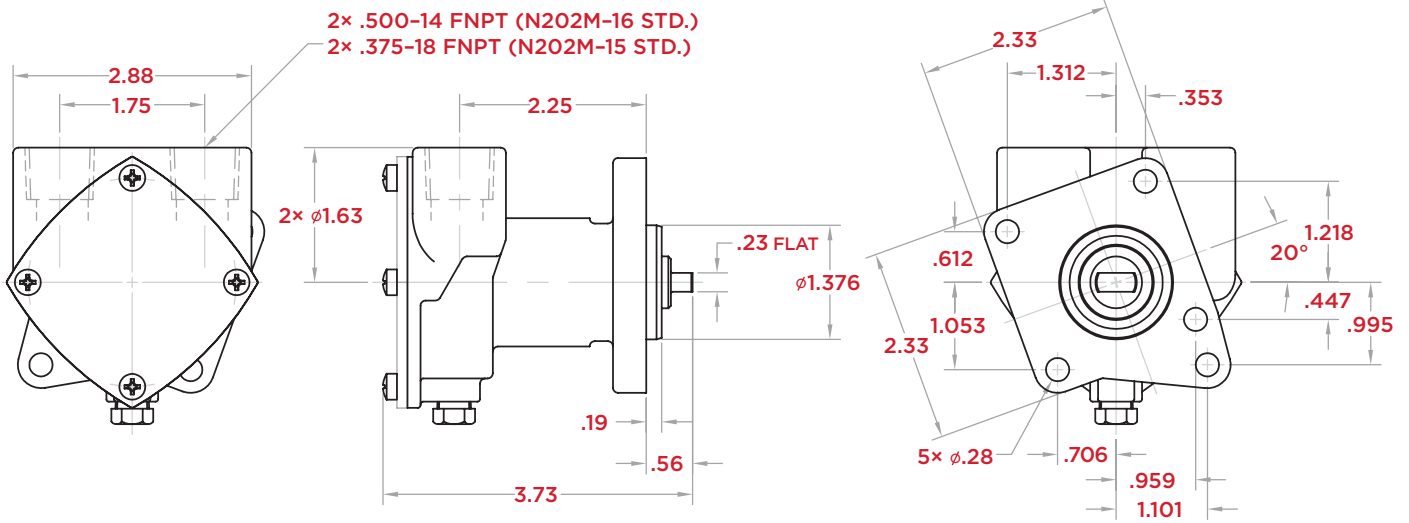

N292M-17

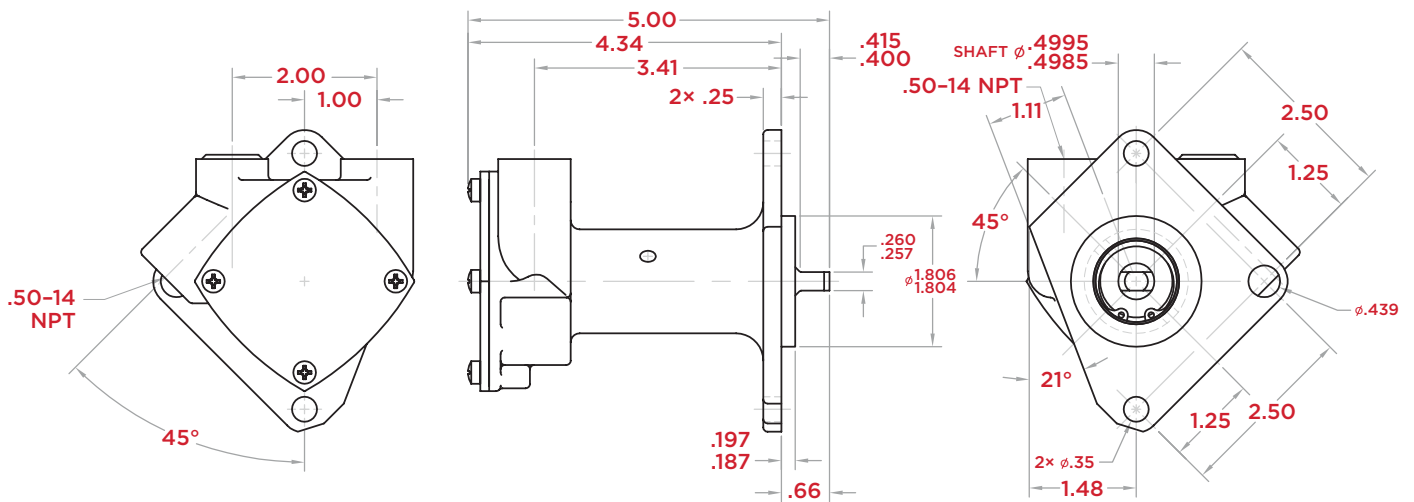

N292M-17P

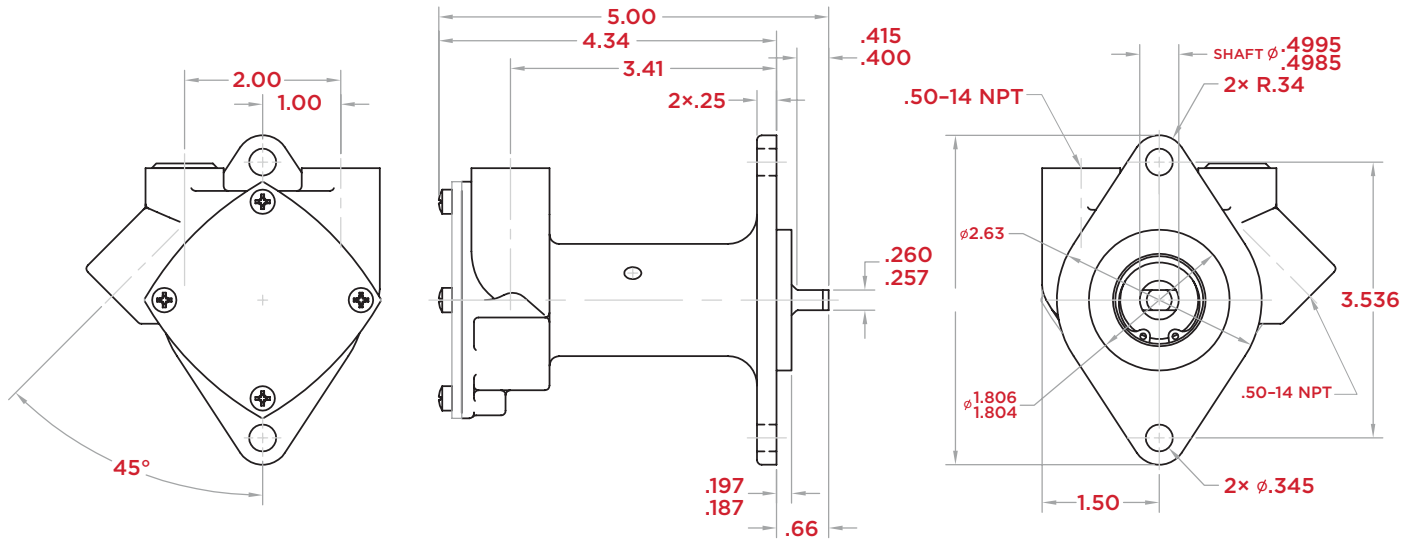

N202M-21

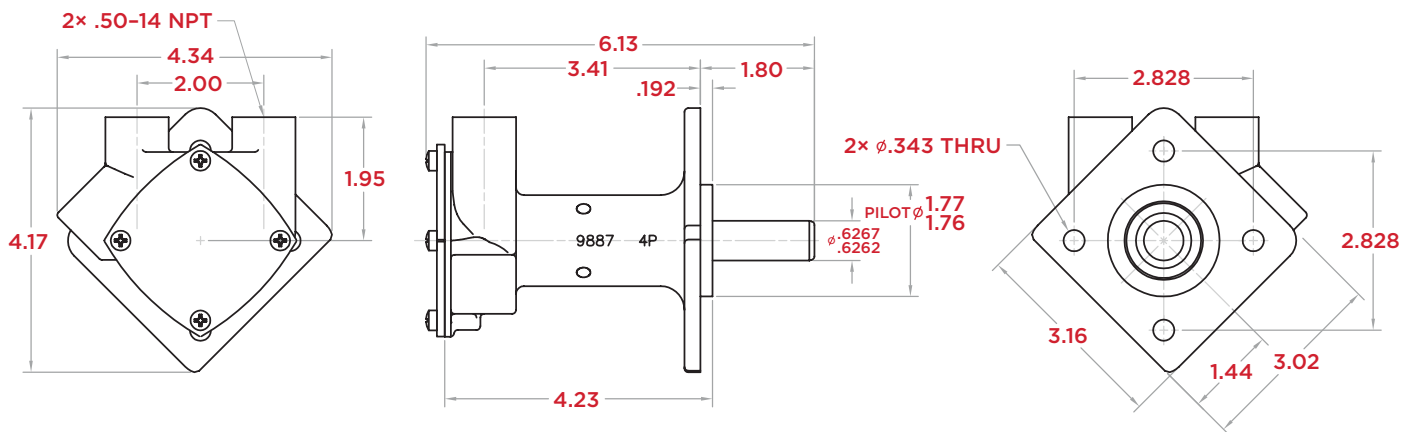

DIMENSIONS

N292M-23

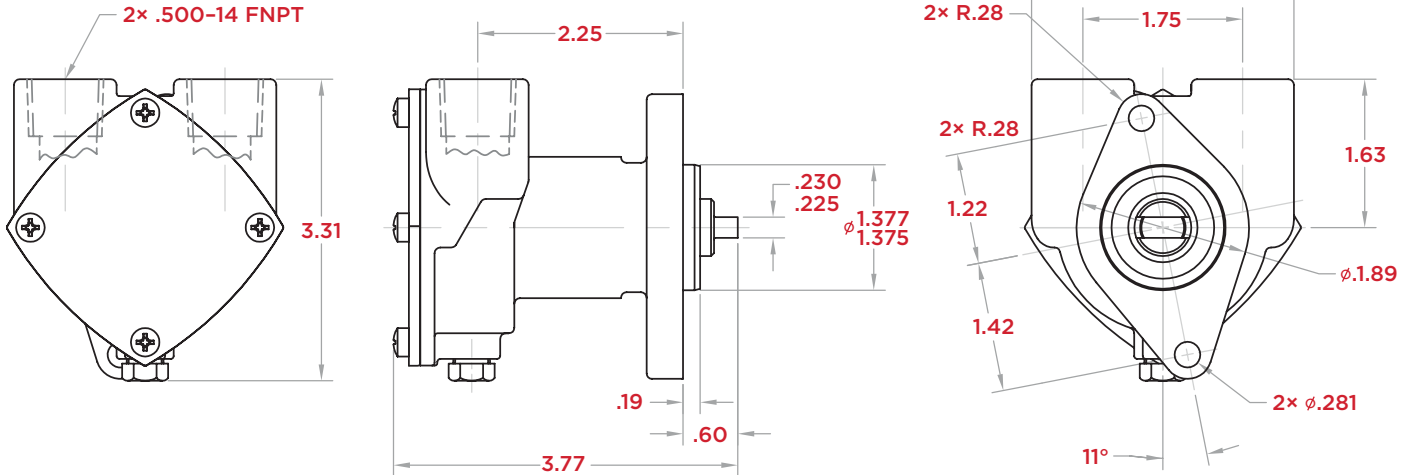

N202M-24

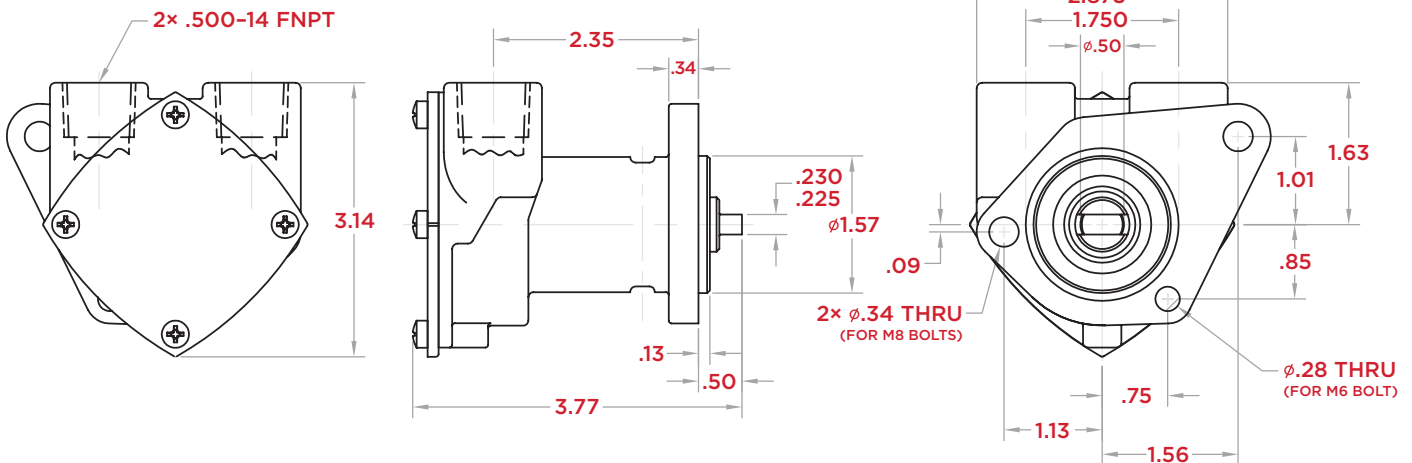

**Gardner
Denver**®

Gardner Denver, Inc.

5900 Firestone Drive
Syracuse, NY 13206

800-448-1668

FluidPump.cs.qcy@gardnerdenver.com

www.oberdorferpumps.com

NBR = Acrylonitrile-Butadiene, PTFE = Polytetrafluorethylene, FKM = Fluoroelastomer

Due to ongoing product improvements, data shown here is subject to change without notice.

Contact Oberdorfer Pumps for latest specifications.

©2019 Gardner Denver, Inc. Printed in U.S.A.

OB-N202M 1st Ed. 4/19

 Please recycle after use.