

Cascade CD101 Auto-Start Controller

Installation and Operations Manual



CL1 DIV 2
GRPA, B, C, D
HAZARDOUS
LOCATIONS

00-02-0594
09-07-11
Sections 40 & 75

In order to consistently bring you the highest quality, full featured products, we reserve the right to change our specifications and designs at any time. The latest version of this manual can be found at www.fwmurphy.com.

Warranty - A limited warranty on materials and workmanship is given with this FW Murphy product.
A copy of the warranty may be viewed or printed by going to <http://www.fwmurphy.com/warranty>



Please read the following information before installing.

BEFORE BEGINNING INSTALLATION OF THIS MURPHY PRODUCT:

- Read and follow all installation instructions.
- A visual inspection of this product for damage during shipping is recommended before mounting.
- It is your responsibility to have a qualified person install this unit and make sure it conforms to NEC and local codes.
- Disconnect all electrical power to the machine.
- Make sure the machine cannot operate during installation.
- Follow all safety warnings of the machine manufacturer.
- Please contact FW MURPHY immediately if you have any questions.

Table of Contents

Operating the Cascade	1
LED Status Lights	2
Setting up the Cascade	4
Modes of Operation.....	4
Installing the Cascade Auto-Start Controller	6
Tools Needed.....	6
Mounting the Cascade	6
Recommended Wiring Practices	7
Typical Wiring Diagrams	8
Specifications	14
Tables	13

(NOTES)

Operating the Cascade

When power is first applied, all LEDs will flash indicating a Lamp Test function.

- To manually start the engine, press the “MAN” (Manual) button. The controller will initiate a normal start sequence.
- In MANUAL MODE, operating the “UP/DOWN” arrow keys will activate Aux outputs 1-4 if they are configured for SPEED UP / SPEED DOWN.
- To manually stop the engine (or turn off the controller), press the “OFF” button.
- To place the controller in automatic mode, press the button labeled “AUTO”. The LED next to the “AUTO” button should come on to indicate that the controller is waiting for the remote start input to become active to initiate a start sequence.
- If there is no activity (key presses or start signal) for 2 minutes, the controller will go into low-power sleep-mode. A start input will wake the controller.
- To reset the controller, press the “OFF” button. Then correct the cause of the shutdown. This will clear all faults except when the aux inputs are programmed for either shutdown immediate or warning immediate, or if the engine ECU is broadcasting a shutdown fault.

In the event of a fault that causes the engine to shutdown, the cause of the event will be indicated on one of the 11 status lights on the right hand side of the controller. When the cause of shutdown is corrected, the controller can resume normal operation.

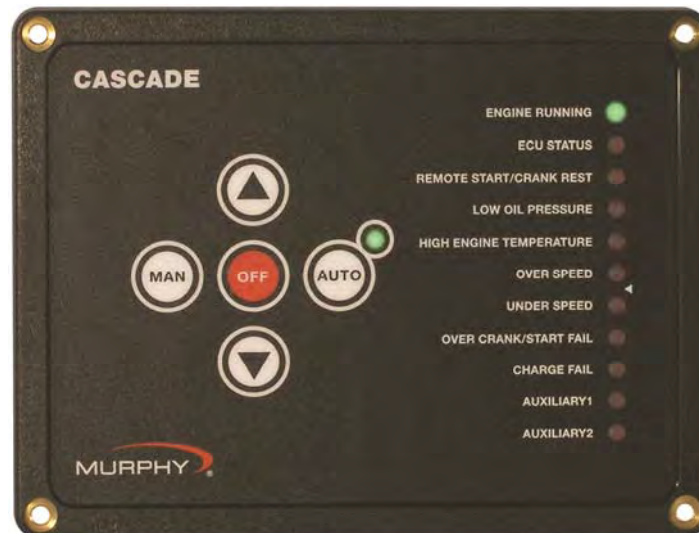

LED Status Lights

Eleven LEDs separated into two banks (see Fig. 1) are provided on the faceplate. The LEDs Bank 1 includes 6 LEDs and Bank 2 includes 5. In Setup mode, these banks form a binary code to indicate either the controller setup configuration or error status, which is indicated by the last 8 (red) LEDs. Refer to Tables 1, 2, 3 and 4 for configuration and status listings.

One LED is located next to the AUTO button to indicate that the controller is waiting for the remote start input to become active.

The LED Status lights are (from top to bottom):

LED Status Light Descriptions:

FIGURE 1

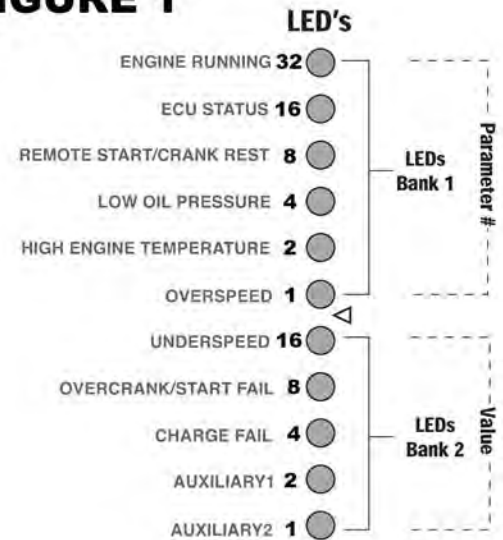

LEDs	Description
Engine Running	If the green LED is ON, then the unit is receiving a speed signal, indicating that the engine is above the crank cut speed.
ECU Status	If the green LED is on solid, it indicates that in a J1939 application the ECU and the unit are communicating properly. If the LED is blinking slowly the ECU is broadcasting a "wait to start" message. If the LED is blinking fast, the ECU is NOT communicating properly.
Remote Start/ Crank Rest	If the green LED is on, then the remote start input is active and if the system is in AUTO mode, it will try to start. If the LED is blinking, the crank cycle has ended and is now in crank rest cycle.
Low Oil Pressure	If the red LED is on, the controller has caused the engine to shutdown and lockout. If the LED is blinking, the engine ECU has transmitted a SPN for an oil pressure related condition. If the LED comes on before the crank sequence, it indicates the Low Oil Pressure Input is not grounded (close/fault) while the engine is off.
High Engine Temperature	If the red LED is on, the controller has caused the engine to shutdown and lockout. If the LED is blinking, the engine ECU has transmitted a SPN for an engine temperature related condition.
Overspeed	If the red LED is on, the controller has caused the engine to shutdown and lock out due to engine speed exceeding the setpoint.
Underspeed	If the red LED is on, the controller has caused the engine to shutdown and lock out due to engine speed falling below the minimum needed for proper operation.

Table continued on next page.

Overcrank/ Start Fail	If the red LED is on, the controller has exceeded the set number of start attempts without receiving a valid speed signal indicating that engine speed is above crank disconnect. This causes the engine to shutdown and lockout.
Charge Fail	If the red LED is on, it indicates that the battery-charging alternator is not charging the cranking batteries, or that the battery charger fail output is on.
Auxiliary 1	If the red LED is on, it indicates that this custom-configured input is active. On an ECU (ECM) equipped engine, if this LED is blinking slowly, it indicates that one or more engine parameters are near exceeding engine manufacturer's setpoints. If the LED is blinking fast, it indicates that one or more engine parameters have exceeded the setpoints, and the ECU has issued a fault. In this case the engine has most likely shut down or is running in a derated condition.
Auxiliary 2	If the red LED is on it indicates that this custom-configured input is active.

For more information, see Table 2 – LED States for Normal Operating Mode.

NOTE: If the Overspeed and Underspeed LED's are both blinking, the controller has lost its speed signal.

Setting up the Cascade

To enter the SETUP MODE, first remove DC power to the Cascade controller for approximately 10 seconds.

On the back of the controller are four DIP switches, set switch #1 to ON (see schematic at right) then restore DC power. The **AUTO** mode LED will blink to indicate that the Cascade is in the **SETUP MODE**.

When in the **SETUP MODE**, pressing the “**MAN**” (Manual) button steps up thru the entire list of parameters. The pattern of the top six LEDs, LEDs Bank 1 (see “Fig. 1”), is used to indicate which parameter is selected. The pattern will change once each time the “**MAN**” button is pressed.

Pressing the “**OFF**” button steps up thru all the available values for each parameter. The pattern of the bottom five LEDs, LEDs Bank 2 (see “Fig. 1”), is used to indicate which value is selected. The pattern will change once each time the **OFF** button is pushed.

Pressing the “**AUTO**” button stores the displayed value.

If any value is changed, it will blink until stored, except a value of zero. If any value is changed but not stored, and then the parameter is changed, the value will still be what was shown originally.

If you accidentally go past a desired parameter or value, you can step back by pressing the down arrow button.

The parameter/value list and corresponding LED indication are shown on Table 1 – Parameter Values and Corresponding LED Indication.

When you are finished with setup, set switch #1 to in the Normal Operating Position (OPEN), remove DC power for 10 seconds, then restore DC power.

Move Switch toward the numbers to Turn On

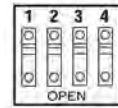

NOTE: Switch settings are read at Power Up only.

Fig. 2

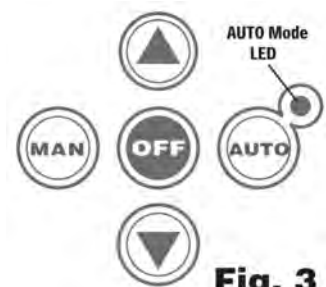

Fig. 3

Modes of Operation

Setup Mode

Refer to the section “Setting up the Cascade” and “Table 1 – Parameter Values and Corresponding LED Indication”.

Normal Operating Mode (Engine Control Mode)

The DIP switch #1 must be in the open position in order to enter this mode upon power up. “Table 2 – LED States for Normal Operating Mode” shows the meaning of each LED state for this mode.

Error Mode

Upon power up, when the DIP switch #1 is in the normal operating position (open position) and an error is detected in the user configuration, the Error Mode will be accessed. The LEDs will blink fast indicating the error. To correct the errors before the unit can operate in Engine Control Mode, the user will need to go back to Setup Mode. “Table 3 – Error Codes LED States” and “Table 4 – Configuration Error Codes” show the meaning of each LED state and configuration for the Error Mode.

Sleep Mode

In **Auto Mode** the Cascade will enter **Sleep Mode** after 2 minutes of inactivity. The unit will exit **Sleep Mode** on key press or remote call to run. It will not enter **Sleep Mode** if there is an active fault.

■ **NOTE:** If PVA Gages are connected, Sleep Mode is not available.

Installing the Cascade Auto-Start Controller

The Cascade controller offers automatic start/stop control with easy configuration for a broad number of engine driven applications.

Tools Needed

To install the Cascade, the following tools are needed:

- #2 Philips (cross head) head screwdriver
- 5/16" Nut driver to fit #6-32 machine nuts
- Wire for hook-up (rising cage clamp suitable for 14-24 gage wire)

Mounting the Cascade



WARNING – Explosion Hazards

This Equipment is suitable for use in Class I, Division 2, Groups A, B, C, and D or Non-hazardous locations only.

Explosion Hazard – Substitution of components may impair suitability for Class I, Division 2.

Explosion Hazard – Do not disconnect equipment while the circuit is live or make sure the area is known to be free of ignitable concentrations.

NOTE: This unit shall be mounted in a Type 1 electrical enclosure (minimum requirement) for other than indoor applications.

Cut a 5.63 x 4.06 in. (143 x 103mm) mounting hole, and drill four 0.169 in. (4.3mm) diameter holes for the mounting screws. See Schematic below:

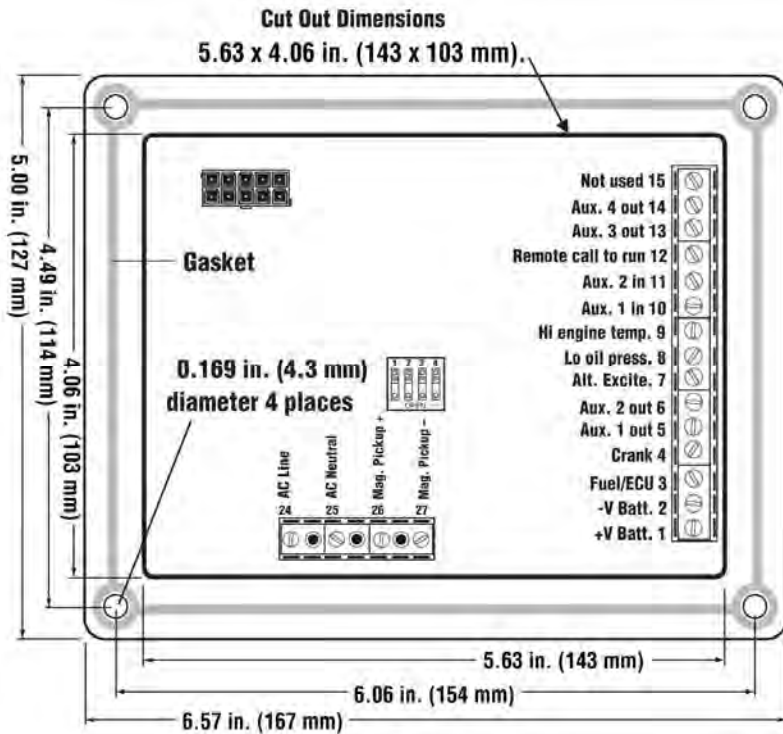

Recommended Wiring Practices



WARNING: For applications involving automatic start equipment, we strongly recommend the installation of an appropriate Emergency Stop safety device.

The CASCADE is designed for pilot-duty use. Outputs should be connected to relays to pilot the loads. Wire the CASCADE controller with 18-gage stranded wire.

1. To help prevent electrical noise and voltage drop to the controller during cranking and preheat, wire the controller DC power connections directly to the cranking battery. This will also help improve “Low battery” starting capability.
2. When using a battery charger, it should be connected directly to the battery to help prevent electrical noise which could cause an engine ECU or associated equipment to operate erratically.
3. Never route low voltage DC wiring in the same conduit as high voltage AC wiring. Noise from electrical loads such as motors and variable frequency drives can be coupled into the engine ECU, governor, or associated equipment and may cause erratic operation.

4. Always use twisted shielded pair wires for the magnetic pickup wiring. Ground one end of the shield only.
5. In spark ignited engine applications, always use resistive spark plugs and spark plug wires, as these greatly reduce the amount of radiated noise.
6. Always place a snubbing diode (sometimes also called a flyback, anti-kickback or reverse bias diode) directly across any inductive load. This helps eliminate a common source of electrical noise, as well as increases the operating lifetime of any solid-state output.
7. Always use twisted shielded pair communications wiring for RS-485 and SAE J1939 compliant wiring for J1939 communications. Make sure that terminating resistors (if required) have the correct rating and are installed properly.

Typical Wiring Diagrams

Cascade – Basic Engine AC Speed Sensing

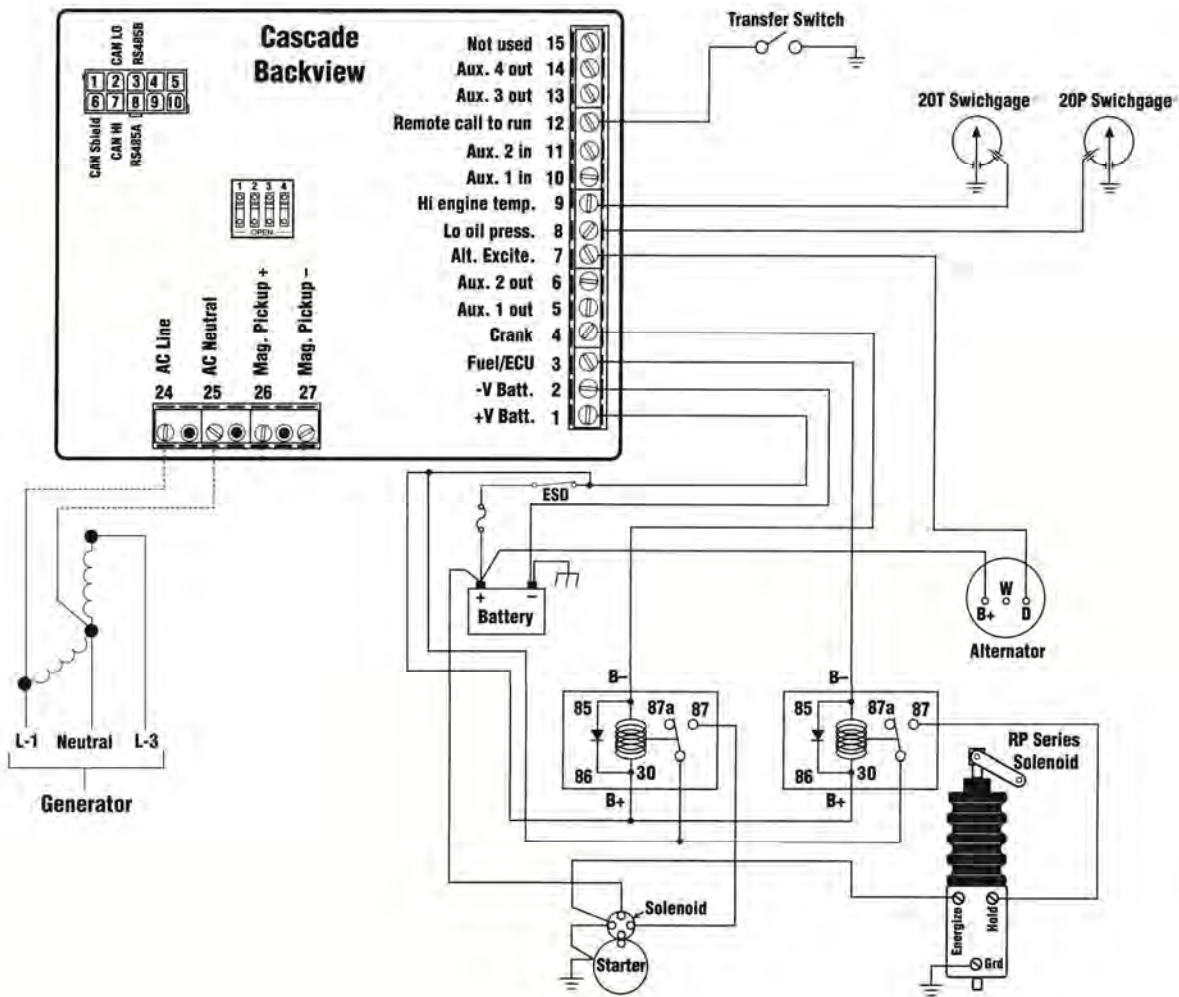

Cascade – Basic Mechanical Engine MPU Speed Sensing

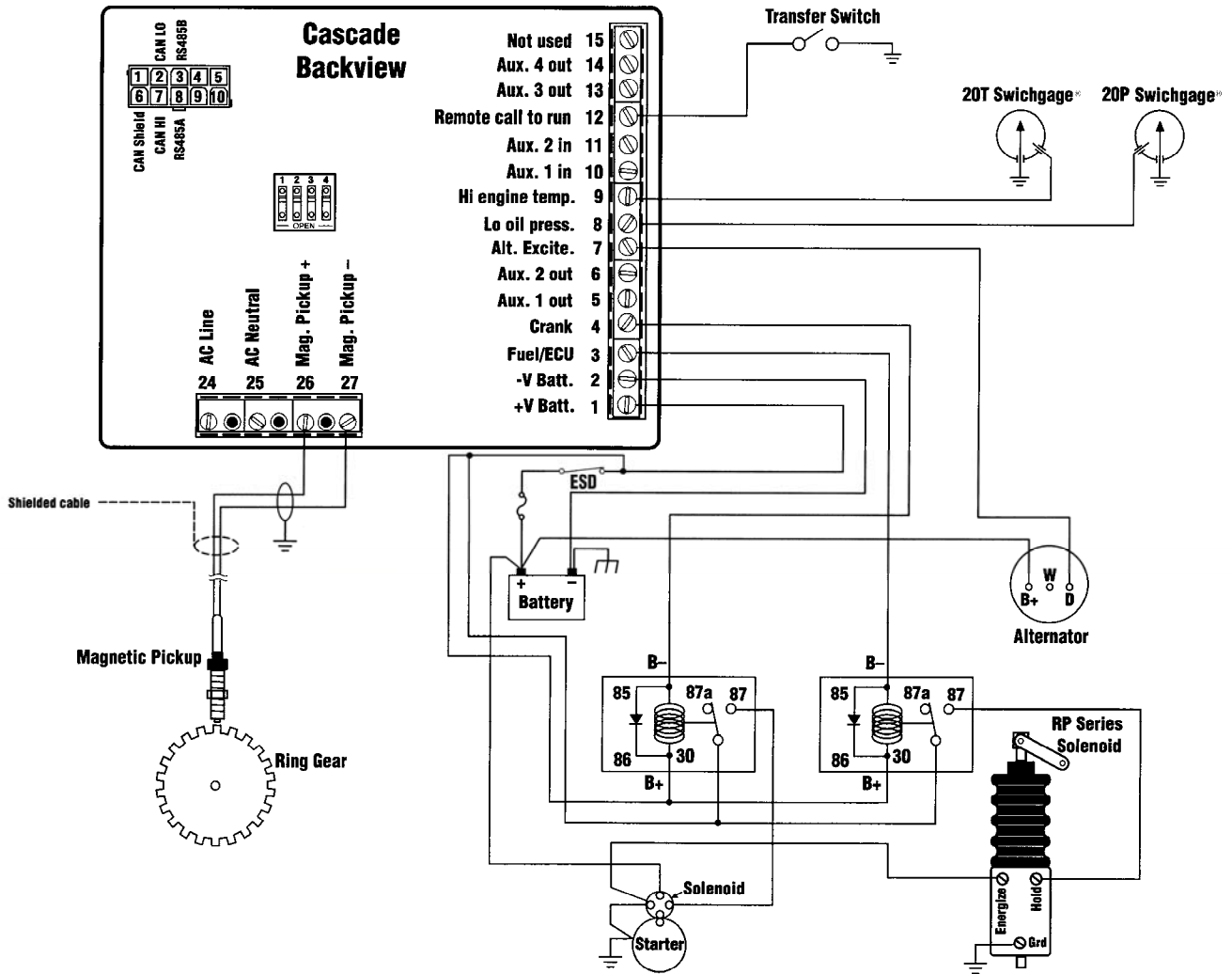

Cascade – Basic ECU Engine ECU Speed Sensing

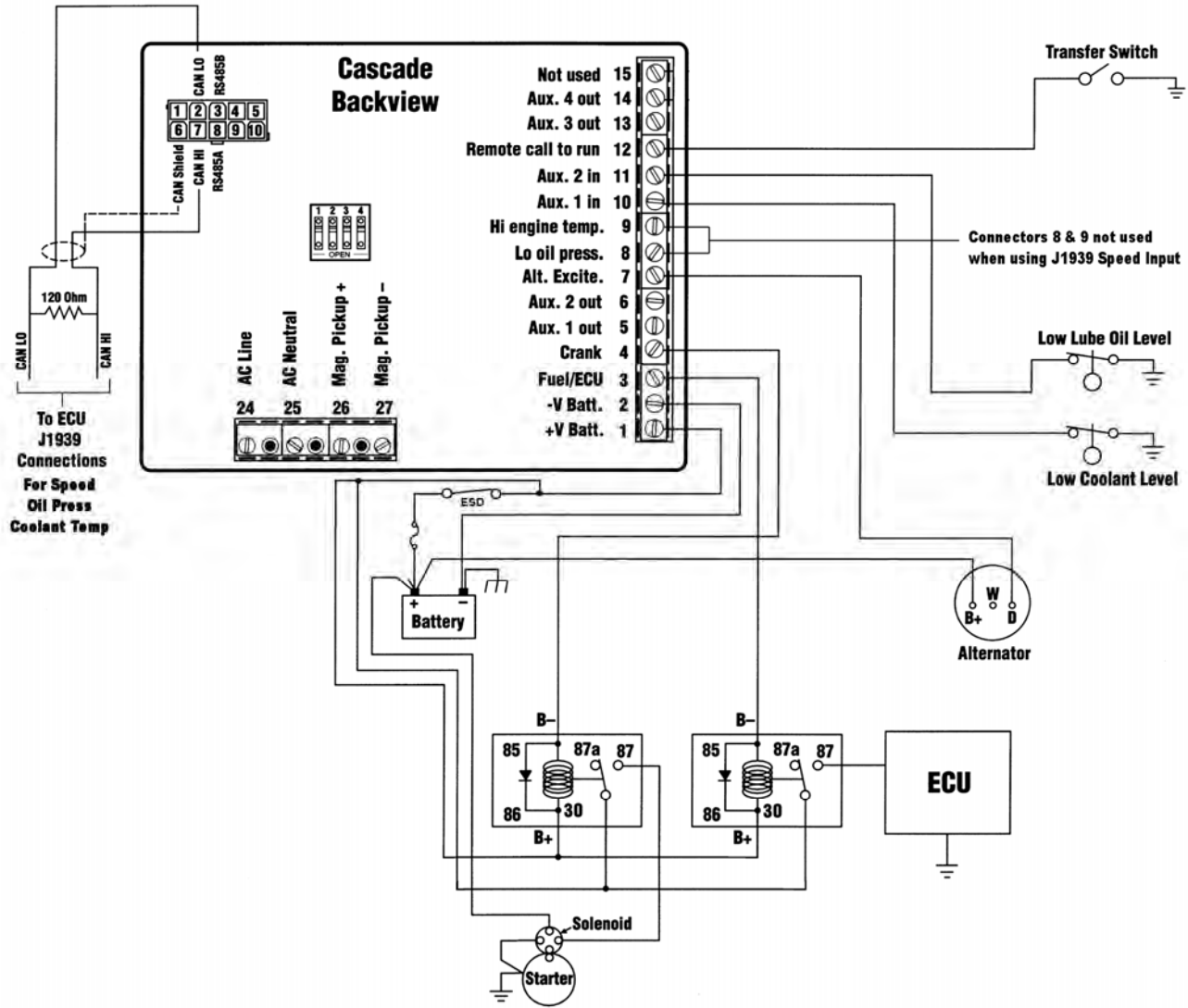

Inc/Dec Throttle (Manual), Line Fill Delay, Low Oil/Coolant Level, Preheat, Common Alarm

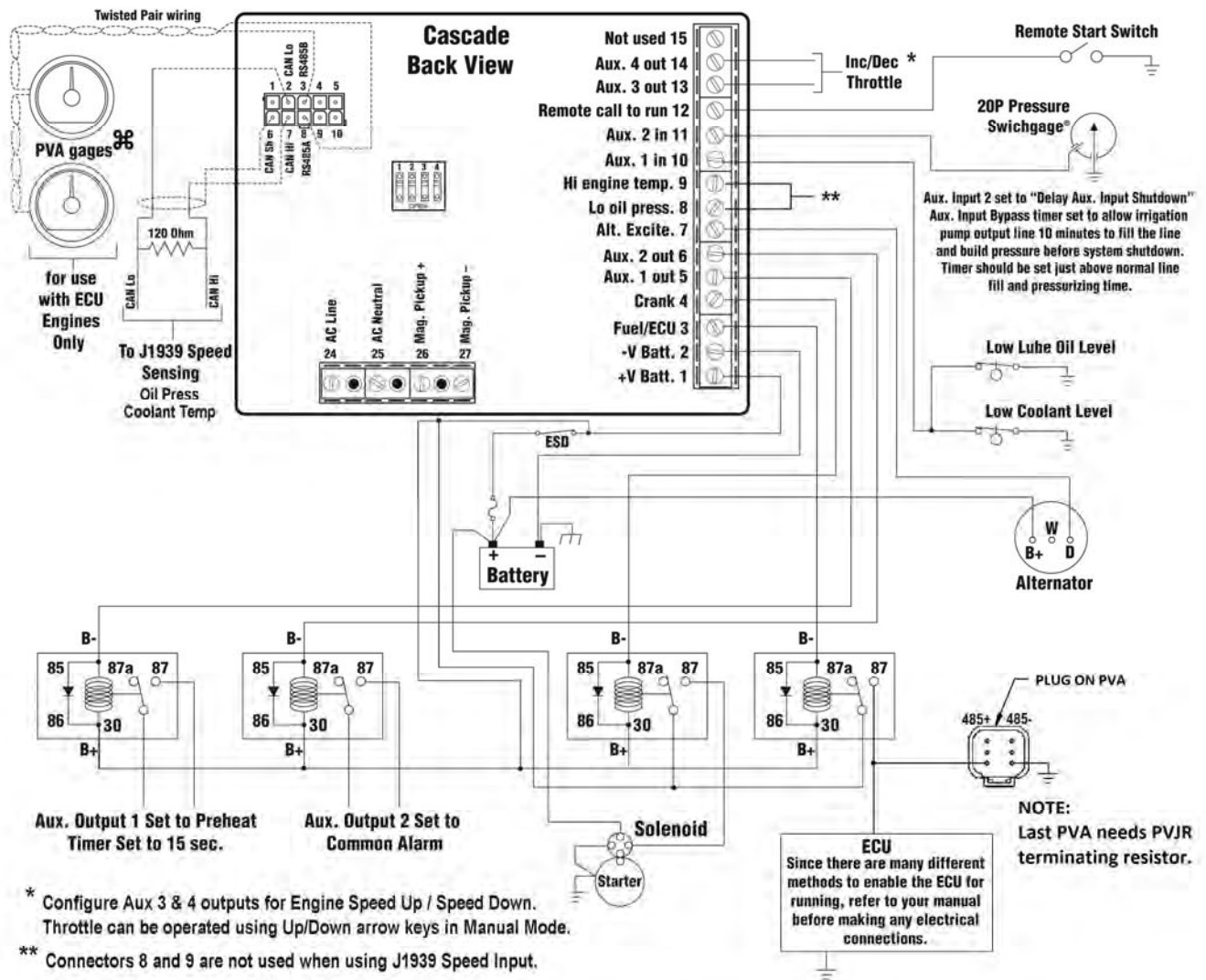

⚡ PVA GAGES Supported:

(PVA20-T-3000) Engine Speed 0 - 3000 RPM	(PVA20-C-12) Battery Voltage 8 - 18 VDC
(PVA35-T-3000) Engine Speed 0 - 3000 RPM	(PVA20-C24) Battery Voltage 16 - 36 VDC
(PVA20-A-100) Engine Oil Pressure 0 - 100 PSI	(PVA-20-AN-80) AC Frequency 40 - 80 Hertz
(PVA20-A-150) Engine Oil Pressure 0 - 150 PSI	(PVAA20) Alarm Gauge Sound, Transistor & Relay Outputs
(PVA20-B-250) Engine Coolant Temperature 100 - 250°F	

Mechanical Engine MPU Speed Source, Low Liquid Level Shutdowns Warmup-Cooldown Output

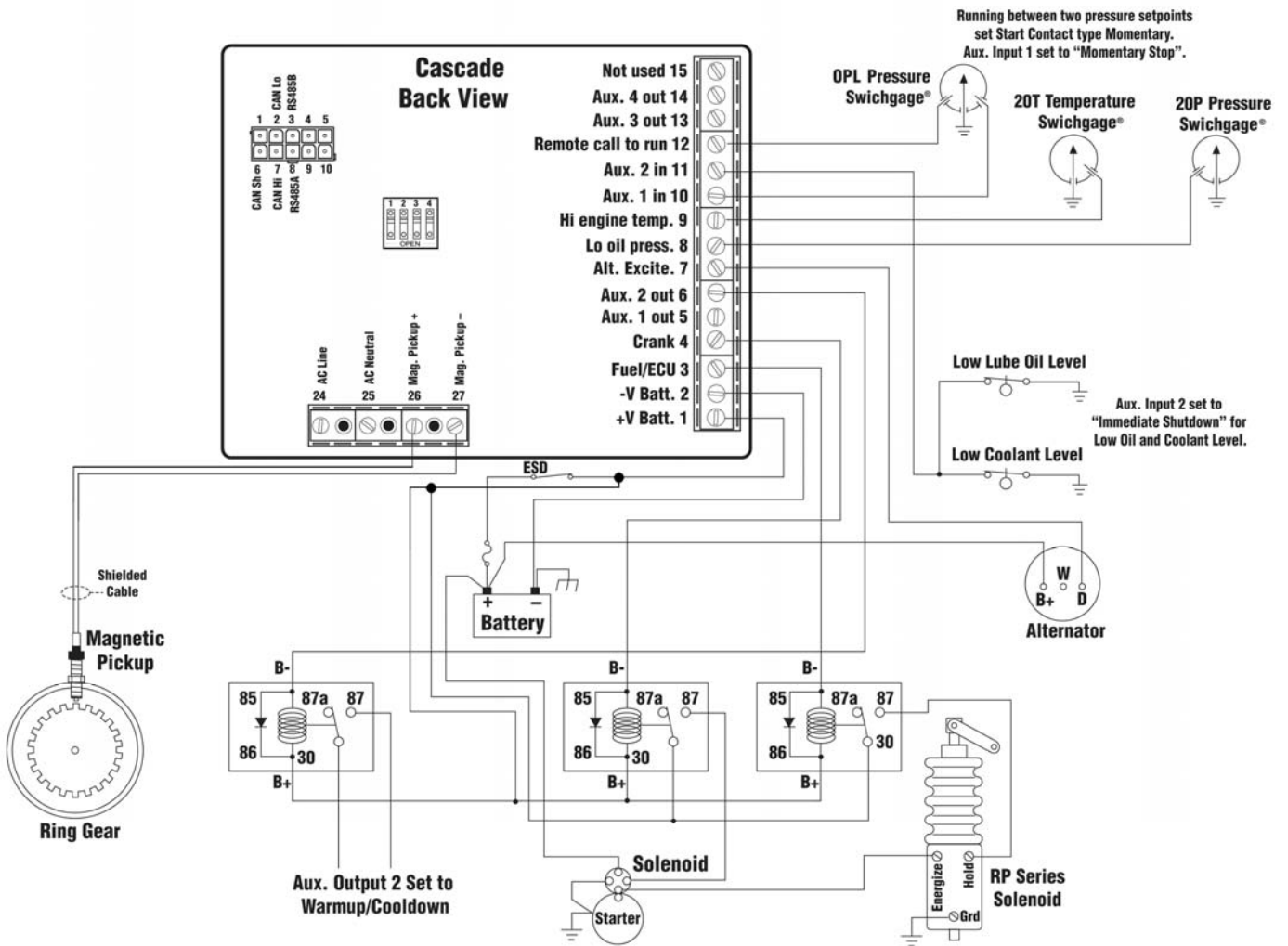

Mechanical Engine Winter/Summer Switch, Preheat Output, and Run & Idle Switch Output

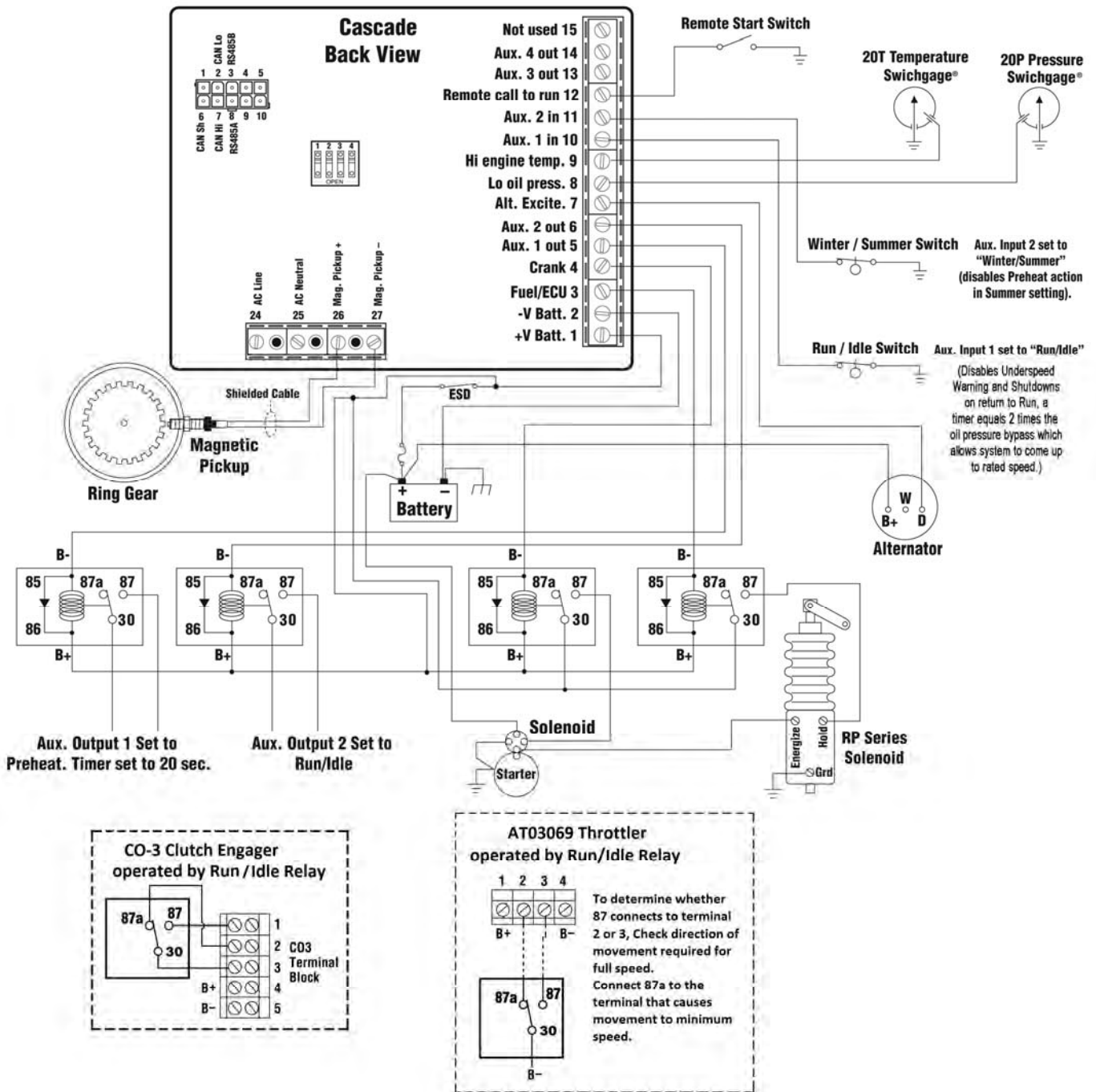

Specifications

Power input: 9-35VDC continuous - operates during total blackout for 2 sec. min.

Power consumption: Sleep Mode (Manual): 2mA typical; (Automatic), 10mA typical.
Running Mode (Manual): 45mA typical; (Automatic): 50mA typical.

Operating/Storage temperature: -40 to 85°C; (-40 to 185°F).

Humidity: 0-100%, non-condensing.

Housing: UV stabilized black polycarbonate and epoxy encapsulation. Weather tight and includes sealing gasket to keep moisture and debris out of enclosure. Properly mounted controller will maintain NEMA4 / IP65 rating of enclosure.

Vibration: Rated to 6G.

Impact: Rated to 10G.

Inputs: Dedicated digital inputs for low oil pressure, high engine temperature, remote start, DC charge fail/Alternator fail. Two aux inputs are configurable for multiple functions.

Outputs: 7 – 4 auxiliary, configurable (1A DC protected). 3 dedicated outputs for Crank, Fuel/ECU, Alternator excitation. Outputs are low side FET switches.

Crank attempts: 3, 5, 10, Continuous.

Crank Rest: 5-60 seconds, adjustable.

Shutdown lockout time delay: 5, 10, 15, 20, 25, 30 seconds.

Crank Disconnect speed setting: Field settable 0-9999 RPM (16-60Hz AC freq input).

Overspeed/underspeed trip point setting: ±5 to 50% of nominal.

Speed sensing inputs: Magnetic pickup (5-120VAC RMS / 0-10 kHz) & AC frequency (30-600VAC RMS / 16-80 Hz).

CANbus interface: Directly reads engine speed, oil pressure, coolant temperature, system voltage, & engine status data* from SAE-J1939 enabled engines.

MODbus interface: In J1939 applications drives PVA series analog gages. Gages limited to tach (0-3000 rpm), coolant temperature, oil pressure (0-100 & 0-150), DC volts (12v & 24v), AC freq, and audible alarm.

**Engine status data limited to low oil pressure, high engine temperature, "Wait to start" status, Warning & Fault lamp information, and communication error.*

Table 1. Parameter Values and Corresponding LED Indication

LEDs shown here form a binary code indicating the configuration value. Shown from Top to bottom the LEDs read from Left to Right (see Fig.1). A filled dot means LED is ON.

Parameter				Parameter					
#	Description	LED Bank 1	Value (*= default)	LED Bank 2	#	Description	LED Bank 1	Value (*= default)	LED Bank 2
1	Engine Speed Source	○ ○ ○ ○ ●	Magnetic Pickup* Generator AC J1939 (ECU)	○ ○ ○ ○ ○ ○ ○ ○ ○ ● ○ ○ ○ ○ ○	13	Aux Input Bypass Timer	○ ○ ● ● ○ ●	30 Sec* 1 Min 2 Min 3 Min 4 Min 5 Min 6 Min 7 Min 8 Min 9 Min 10 Min 15 Min 20 Min 25 Min 30 Min 35 Min 40 Min 45 Min 50 Min 55 Min 1 Hr	○ ○ ○ ○ ○ ○ ○ ○ ○ ● ○ ○ ○ ○ ○ ○ ○ ○ ○ ● ○ ○ ○ ○ ○ ○ ○ ○ ○ ○ ○ ○ ○ ○ ○ ○ ○ ○ ○ ○ ○ ○ ○ ○ ○ ○ ○ ○ ○ ○ ○ ○ ○ ○ ○ ○ ○ ○ ○ ○ ○ ○ ○ ○ ○ ○ ○ ○ ○ ○ ○ ○ ○ ○ ○ ○ ○ ○ ○ ○ ○ ○ ○ ○ ○ ○ ○ ○ ○ ○ ○ ○ ○ ○ ○ ○ ○ ○ ○ ○ ○ ○ ○ ○ ○
2	Crank Attempts	○ ○ ○ ○ ● ○	3* 5 10 Continuous	○ ○ ○ ○ ○ ○ ○ ○ ○ ● ○ ○ ○ ○ ○ ○ ○ ○ ○ ●	14	Cranking Motor Abutment Protection Delay (Current crank attempt is aborted if an RPM greater than 10 is not detected after this delay from start of crank has expired) (MPU and J1939 speed source only)	○ ○ ○ ○ ○ ○	Disabled* 1.00 s 1.25 s 1.50 s 1.75 s 2.00 s 2.25 s 2.50 s 2.75 s 3.00 s 3.25 s 3.50 s 3.75 s 4.00 s 4.25 s 4.50 s 4.75 s 5.00 s	○ ○ ○ ○ ○ ○ ○ ○ ○ ● ○ ○ ○ ○ ○ ○ ○ ○ ○ ● ○ ○ ○ ○ ○ ○ ○ ○ ○ ○ ○ ○ ○ ○ ○ ○ ○ ○ ○ ○ ○ ○ ○ ○ ○ ○ ○ ○ ○ ○ ○ ○ ○ ○ ○ ○ ○ ○ ○ ○ ○ ○ ○ ○ ○ ○ ○ ○ ○ ○ ○ ○ ○ ○ ○ ○ ○ ○ ○ ○ ○ ○ ○ ○ ○ ○ ○ ○ ○ ○ ○ ○ ○ ○ ○ ○ ○ ○ ○ ○ ○ ○ ○ ○ ○
3	Crank Timer	○ ○ ○ ○ ● ●	5 Sec 10 Sec 15 Sec* 20 Sec 25 Sec 30 Sec 45 Sec 60 Sec	○ ○ ○ ○ ○ ○ ○ ○ ○ ● ○ ○ ○ ○ ○ ○ ○ ○ ○ ● ○ ○ ○ ○ ○ ○ ○ ○ ○ ○ ○ ○ ○ ○ ○ ○ ○ ○ ○ ○	15		Remote Start Signal Type	○ ○ ● ● ● ●	Maintained* Momentary
4	Crank Rest Timer	○ ○ ○ ● ○ ○	5 Sec 10 Sec 15 Sec* 20 Sec 25 Sec 30 Sec 45 Sec 60 Sec	○ ○ ○ ○ ○ ○ ○ ○ ○ ● ○ ○ ○ ○ ○ ○ ○ ○ ○ ● ○ ○ ○ ○ ○ ○ ○ ○ ○ ○ ○ ○ ○ ○ ○ ○ ○ ○ ○ ○	16	Digital Input 1	○ ● ○ ○ ○ ○	Lo Oil Press (Open/Fault) Lo Oil Press (Close/Fault)*	○ ○ ○ ○ ○ ○ ○ ○ ○ ●
5	Start Delay Timer (auto mode only)	○ ○ ○ ● ○ ●	0 Sec* 5 Sec 10 Sec 15 Sec 30 Sec 60 Sec	○ ○ ○ ○ ○ ○ ○ ○ ○ ● ○ ○ ○ ○ ○ ○ ○ ○ ○ ● ○ ○ ○ ○ ○ ○ ○ ○ ○ ○ ○ ○ ○ ○ ○	17	Digital Input 2	○ ● ○ ○ ○ ●	Hi Eng Temp (Open/Fault) Hi Eng Temp (Close/Fault)*	○ ○ ○ ○ ○ ○ ○ ○ ○ ●
6	Stop Delay Timer (auto mode only)	○ ○ ○ ● ○ ○	0 Sec* 5 Sec 10 Sec 15 Sec 30 Sec 60 Sec	○ ○ ○ ○ ○ ○ ○ ○ ○ ● ○ ○ ○ ○ ○ ○ ○ ○ ○ ● ○ ○ ○ ○ ○ ○ ○ ○ ○ ○	18	Digital Input 3 (Auxiliary Input 1)	○ ● ○ ○ ○ ○	Not Used* Winter/Summer Momentary Stop Immediate Warning Delayed Warning Immediate Shutdown Delayed Shutdown Delayed Aux Input Shtdwn Run/Idle (Line Fill) Auxiliary Crank Disconnect Remote Reset (Clear Faults)	○ ○ ○ ○ ○ ○ ○ ○ ○ ● ○ ○ ○ ○ ○ ○ ○ ○ ○ ● ○ ○ ○ ○ ○ ○ ○ ○ ○ ● ○ ○ ○ ○ ○ ○ ○ ○ ○ ○ ○ ○ ○ ○ ○ ○ ○ ○ ○ ○ ○ ○ ○ ○ ○ ○ ○ ○ ○ ○ ○ ○ ○ ○ ○ ○ ○ ○ ○ ○ ○ ○ ○ ○ ○ ○ ○ ○ ○ ○ ○ ○ ○ ○ ○ ○ ○ ○ ○ ○ ○ ○ ○ ○ ○ ○ ○ ○ ○ ○ ○ ○ ○ ○ ○
7	Preheat Timer	○ ○ ○ ● ● ●	0 Sec* 5 Sec 10 Sec 15 Sec 20 Sec 25 Sec 30 Sec 45 Sec 60 Sec	○ ○ ○ ○ ○ ○ ○ ○ ○ ● ○ ○ ○ ○ ○ ○ ○ ○ ○ ● ○ ○ ○ ○ ○ ○ ○ ○ ○ ○ ○ ○ ○ ○ ○ ○ ○ ○ ○ ○	19	Digital Input 4 (Auxiliary Input 2)	○ ● ○ ○ ● ●	Not Used* Winter/Summer Momentary Stop Immediate Warning Delayed Warning Immediate Shutdown Delayed Shutdown Delayed Aux Input Shtdwn Run/Idle (Line Fill) Auxiliary Crank Disconnect Remote Reset (Clear Faults)	○ ○ ○ ○ ○ ○ ○ ○ ○ ● ○ ○ ○ ○ ○ ○ ○ ○ ○ ● ○ ○ ○ ○ ○ ○ ○ ○ ○ ● ○ ○ ○ ○ ○ ○ ○ ○ ○ ○ ○ ○ ○ ○ ○ ○ ○ ○ ○ ○ ○ ○ ○ ○ ○ ○ ○ ○ ○ ○ ○ ○ ○ ○ ○ ○ ○ ○ ○ ○ ○ ○ ○ ○ ○ ○ ○ ○ ○ ○ ○ ○ ○ ○ ○ ○ ○ ○ ○ ○ ○ ○ ○ ○ ○ ○ ○ ○ ○ ○ ○ ○ ○ ○ ○
8	Extended Preheat during Crank (only used if preheat timer is also set to a non-zero value) (must be less than or equal to crank timer)	○ ○ ● ○ ○ ○	0 Sec* 5 Sec 10 Sec 15 Sec 20 Sec 25 Sec 30 Sec 45 Sec 60 Sec	○ ○ ○ ○ ○ ○ ○ ○ ○ ● ○ ○ ○ ○ ○ ○ ○ ○ ○ ● ○ ○ ○ ○ ○ ○ ○ ○ ○ ○ ○ ○ ○ ○ ○ ○ ○ ○ ○ ○	22	Fuel Relay Control (non ECU Engines) Note: On ECU engines, fuel relay is used for ECU power	○ ● ○ ● ○ ○	Energized to Run* Energized to Stop	○ ○ ○ ○ ○ ○ ○ ○ ○ ●
9	Warmup Timer	○ ○ ● ○ ○ ●	0 min.* 1 min. 5 min. 10 min.	○ ○ ○ ○ ○ ○ ○ ○ ○ ● ○ ○ ○ ○ ○ ○ ○ ○ ○ ●					
10	Cooldown Timer	○ ○ ● ○ ○ ○	0 min.* 1 min. 5 min. 10 min.	○ ○ ○ ○ ○ ○ ○ ○ ○ ● ○ ○ ○ ○ ○ ○ ○ ○ ○ ●					
11	Bypass Timer	○ ○ ● ○ ● ●	0 Sec 5 Sec 10 Sec* 15 Sec 20 Sec 25 Sec 30 Sec	○ ○ ○ ○ ○ ○ ○ ○ ○ ● ○ ○ ○ ○ ○ ○ ○ ○ ○ ● ○ ○ ○ ○ ○ ○ ○ ○ ○ ○ ○ ○ ○ ○ ○					
12	Energize to Stop Timer	○ ○ ● ● ○ ○	15 Sec* 30 Sec	○ ○ ○ ○ ○ ○ ○ ○ ○ ●					

Table 1. Parameter Values and Corresponding LED Indication (continued)

LEDs shown here form a binary code indicating the configuration value. Shown from Top to bottom the LEDs read from Left to Right (see Fig.1). A filled dot means LED is ON.

Parameter				Parameter													
#	Description	LED Bank 1	Value (*= default)	LED Bank 2	#	Description	LED Bank 1	Value (*= default)	LED Bank 2								
23	Auxiliary Output 1	○○●○○●	Not Used*	○○○○○				Lo Oil Press Shutdown	○○○○●								
			Warmup	○○○○●				Hi Eng Temp. Shutdown	○○○○○								
			Cooldown	○○○○○				Overspeed Shutdown	○○○○●								
			Warmup/Cooldown	○○○○●				Overcrank Shutdown	○○○○○								
			Preheat	○○○○○				Alternator Fail/Battery	○○○○○								
			Engine Running	○○○○●				High/Low/Weak	○○○○●								
			At Load	○○○○●				Engine Speed Up	○○○○○								
			Lo Oil Press Shutdown	○○○○●				Engine Speed Down	○○○○●								
			Hi Eng Temp. Shutdown	○○○○○				Common Alarm	○○○○○								
			Overspeed Shutdown	○○○○●				Controller in	○○○○○								
			Overcrank Shutdown	○○○○○				AUTO mode	○○○○○								
			Alternator Fail/Battery	○○○○○				Shutdown	●○○○○								
			High/Low/Weak	○○○○●				Loss of Speed	○○○○○								
			Engine Speed Up	○○○○○				Signal Fault	●○○○○								
			Engine Speed Down	○○○○○				Underspeed Fault	●○○○○								
24	Auxiliary Output 2	○○●○○○○	Not Used*	○○○○○		28		○○●○○○	Power-Up in Manual*	○○○○○							
			Warmup	○○○○●					Power-Up in Automatic	○○○○○							
			Cooldown	○○○○○					29	Oil Pressure Crank Disconnect Delay (non-ECU engines only)	○○●○○●	Not Used*	○○○○○				
			Warmup/Cooldown	○○○○●								0 s	○○○○○				
			Preheat	○○○○○								0.25 s	○○○○○				
			Engine Running	○○○○●								0.50 s	○○○○○				
			At Load	○○○○●								0.75 s	○○○○○				
			Lo Oil Press Shutdown	○○○○●								1.00 s	○○○○○				
			Hi Eng Temp. Shutdown	○○○○○								1.25 s	○○○○○				
			Overspeed Shutdown	○○○○●								1.50 s	○○○○○				
			Overcrank Shutdown	○○○○○								1.75 s	○○○○○				
			Alternator Fail/Battery	○○○○○								2.00 s	○○○○○				
			High/Low/Weak	○○○○●								2.25 s	○○○○○				
			Engine Speed Up	○○○○○								2.50 s	○○○○○				
			Engine Speed Down	○○○○○								2.75 s	○○○○○				
Common Alarm	○○○○○	3.00 s	○○○○○														
Controller in	○○○○○	3.25 s	○○○○○														
AUTO mode	○○○○○	3.50 s	○○○○○														
Shutdown	●○○○○	3.75 s	●○○○○														
Loss of Speed	○○○○○	4.00 s	●○○○○														
Signal Fault	●○○○○	4.25 s	●○○○○														
Underspeed Fault	●○○○○	4.50 s	●○○○○														
25	Auxiliary Output 3	○○●○○○○	Not Used*	○○○○○		30	Nominal Generator Frequency (genset only)	○○●○○○	50 Hz	○○○○○							
			Warmup	○○○○●					60 Hz*	○○○○○							
			Cooldown	○○○○○					31	Crank Disconnect Freq (Generator AC speed source only) (10's digit)	○○●○○●	0	○○○○○				
			Warmup/Cooldown	○○○○●								1	○○○○○				
			Preheat	○○○○○								2*	○○○○○				
			Engine Running	○○○○●								3	○○○○○				
			At Load	○○○○●								4	○○○○○				
			Lo Oil Press Shutdown	○○○○●								5	○○○○○				
			Hi Eng Temp. Shutdown	○○○○○								6	○○○○○				
			Overspeed Shutdown	○○○○●								32	Crank Disconnect Freq (Generator AC speed source only) (1's digit)	●○○○○○	0*	○○○○○	
			Overcrank Shutdown	○○○○○											1	○○○○○	
			Alternator Fail/Battery	○○○○○											2	○○○○○	
			High/Low/Weak	○○○○●											3	○○○○○	
			Engine Speed Up	○○○○○											4	○○○○○	
			Engine Speed Down	○○○○○											5	○○○○○	
Common Alarm	○○○○○	6	○○○○○														
Controller in	○○○○○	7	○○○○○														
AUTO mode	○○○○○	8	○○○○○														
Shutdown	●○○○○	9	○○○○○														
Loss of Speed	○○○○○	33	Crank Disconnect RPM (ECU or MPU speed source only) (1000's digit)	●○○○○○	0*	○○○○○											
Signal Fault	●○○○○				1	○○○○○											
Underspeed Fault	●○○○○				2	○○○○○											
26	Auxiliary Output 4				○○●○○○○	Not Used*	○○○○○		34	Crank Disconnect RPM (ECU or MPU speed source only)	●○○○○○				0	○○○○○	
						Warmup	○○○○●								1	○○○○○	
						Cooldown	○○○○○					2	○○○○○				
						Warmup/Cooldown	○○○○●										
						Preheat	○○○○○										
						Engine Running	○○○○●										
						At Load	○○○○●										

Table 1. Parameter Values and Corresponding LED Indication (continued)

LEDs shown here form a binary code indicating the configuration value. Shown from Top to bottom the LEDs read from Left to Right (see Fig.1). A filled dot means LED is ON.

Parameter				Parameter					
#	Description	LED Bank 1	Value (*= default)	LED Bank 2	#	Description	LED Bank 1	Value (*= default)	LED Bank 2
	(100's digit)		3	○○○○●				235 deg F	○○○○○
			4	○○○○○				240 deg F	○○○○●
			5*	○○○○○				245 deg F	○○○○○
			6	○○○○○				250 deg F	○○○○○
			7	○○○○○					
			8	○○○○○					
			9	○○○○○					
35	Crank Disconnect RPM (ECU or MPU speed source only) (10's digit)	●○○○○	0	○○○○○	42	Lo Batt Voltage Setpoint.	●○○○○	Warning Disabled	○○○○○
			1	○○○○○				8.5V	○○○○○
			2	○○○○○				9.0V	○○○○○
			3	○○○○○				9.5V	○○○○○
			4*	○○○○○				10.0V	○○○○○
			5	○○○○○				10.5V*	○○○○○
			6	○○○○○				11.0V	○○○○○
			7	○○○○○				11.5V	○○○○○
			8	○○○○○				18.0V	○○○○○
			9	○○○○○				19.0V	○○○○○
36	Crank Disconnect RPM (ECU or MPU speed source only) (1's digit)	●○○○○	0*	○○○○○				20.0V	○○○○○
			1	○○○○○				21.0V	○○○○○
			2	○○○○○				22.0V	○○○○○
			3	○○○○○				22.5V	○○○○○
			4	○○○○○				23.0V	○○○○○
			5	○○○○○				23.5V	○○○○○
			6	○○○○○					
			7	○○○○○					
			8	○○○○○					
			9	○○○○○					
37	Overspeed Setpoint (% above run speed)	●○○○○	5%	○○○○○	43	Hi Batt Voltage Setpoint.	●○○○○	Warning Disabled	○○○○○
			10%*	○○○○○				12.5V	○○○○○
			15%	○○○○○				13.0V	○○○○○
			20%	○○○○○				13.5V	○○○○○
			25%	○○○○○				14.0V	○○○○○
			30%	○○○○○				14.5V*	○○○○○
			35%	○○○○○				15.0V	○○○○○
			40%	○○○○○				16.0V	○○○○○
			45%	○○○○○				24.5V	○○○○○
			50%	○○○○○				25.0V	○○○○○
								25.5V	○○○○○
								26.0V	○○○○○
								26.5V	○○○○○
								27.0V	○○○○○
								28.0V	○○○○○
								29.0V	○○○○○
								30.0V	○○○○○
								31.0V	○○○○○
38	Underspeed Setpoint (% below run speed)	●○○○○	5%	○○○○○	44	Weak Battery Voltage Setpoint	●○○○○	Warning disabled	○○○○○
			10%	○○○○○				6.0 V	○○○○○
			15%	○○○○○				6.5 V	○○○○○
			20%*	○○○○○				7.0 V	○○○○○
			25%	○○○○○				7.5 V	○○○○○
			30%	○○○○○				8.0 V	○○○○○
			35%	○○○○○				8.5 V	○○○○○
			40%	○○○○○				9.0 V	○○○○○
			45%	○○○○○				9.5 V	○○○○○
			50%	○○○○○				12.0 V	○○○○○
								13.0 V	○○○○○
								14.0 V	○○○○○
								15.0 V	○○○○○
								16.0 V	○○○○○
								17.0 V	○○○○○
								18.0 V	○○○○○
								19.0 V	○○○○○
								20.0 V	○○○○○
39	Underspeed Response	●○○○○	None.	○○○○○	48	Flywheel Tooth Count (MPU speed source only) (100's digit)	●○○○○	0	○○○○○
			Warning*	○○○○○				1*	○○○○○
			Shutdown	○○○○○				2	○○○○○
				○○○○○				3	○○○○○
40	Lo Oil Press Shutdown Setpoint (ECU eng. only)	●○○○○	Disabled (no shutdown)	○○○○○	49	Flywheel Tooth Count (MPU speed source only) (10's digit)	●○○○○	0	○○○○○
			0 PSI	○○○○○				1	○○○○○
			5 PSI	○○○○○				2	○○○○○
			10 PSI	○○○○○				3	○○○○○
			15 PSI	○○○○○				4	○○○○○
			20 PSI	○○○○○				5	○○○○○
			25 PSI	○○○○○				6*	○○○○○
			30 PSI*	○○○○○				7	○○○○○
			35 PSI	○○○○○				8	○○○○○
			40 PSI	○○○○○				9	○○○○○
			45 PSI	○○○○○					
			50 PSI	○○○○○					
			55 PSI	○○○○○					
			60 PSI	○○○○○					
41	Hi Eng Temp. Shutdown Setpoint (ECU engines only)	●○○○○	Disabled (no shutdown)	○○○○○					
			190 deg F	○○○○○					
			195 deg F	○○○○○					
			200 deg F	○○○○○					
			205 deg F	○○○○○					
			210 deg F	○○○○○					
			215 deg F	○○○○○					
			220 deg F	○○○○○					
			225 deg F	○○○○○					
			230 deg F*	○○○○○					

Parameter			Parameter						
#	Description	LED Bank 1	Value (*= default)	LED Bank 2	#	Description	LED Bank 1	Value (*= default)	LED Bank 2
50	Flywheel Tooth Count (MPU speed source only) (1's digit)	●●●○○	0 1 2 3 4 5 6 7 8* 9	○○○○○ ○○○○● ○○○○○ ○○○○● ○○○○○ ○○○○● ○○○○○ ○○○○● ○○○○○ ○○○○●	53	Run Speed (ECU or MPU speed source only) (10's digit)	●●●○○	0* 1 2 3 4 5 6 7 8 9	○○○○○ ○○○○● ○○○○○ ○○○○● ○○○○○ ○○○○● ○○○○○ ○○○○● ○○○○○ ○○○○●
51	Run Speed (ECU or MPU speed source only) (1000's digit)	●●●○○	0 1* 2 3 4	○○○○○ ○○○○○ ○○○○○ ○○○○○ ○○○○○	54	Run Speed (ECU or MPU speed source only) (1's digit)	●●●○○	0* 1 2 3 4 5 6 7 8 9	○○○○○ ○○○○● ○○○○○ ○○○○● ○○○○○ ○○○○● ○○○○○ ○○○○● ○○○○○ ○○○○●
52	Run Speed (ECU or MPU speed source only) (100's digit)	●●●○○	0 1 2 3 4 5 6 7 8* 9	○○○○○ ○○○○● ○○○○○ ○○○○● ○○○○○ ○○○○● ○○○○○ ○○○○● ○○○○○ ○○○○●	59	Fault Code SPN Conversion Method (ECU Eng. only) Note: if the ECU is using version 4, any of these options will work.	●●●○○	Version 1 & 4 * Version 2 & 4 Version 3 & 4	○○○○○ ○○○○○ ○○○○○ ○○○○○

NOTE: Not all configuration parameters are used. Some are skipped because they are reserved for future expansion.

Table 2. LED States for Normal Operating Mode

LED	OFF	ON	Slow Blink	Fast Blink
AUTO	Manual Start Mode	Auto Start Mode		
Engine Running	Engine is not Running	Engine is Running	Engine is cranking	
ECU Status	Non-ECU configuration	Valid CAN Activity (no errors, Error Active state)	Wait-to-Start	Bus Off/Error Passive/Failed Address Claim
Remote Start/Crank Rest	Remote start input is inactive and manual start has not been initiated	Remote Start active	In Crank Rest or one of the prestart states (startdelay, preheat, waitecu, wait rpm)	No J1939 data when ECU is on
Low Oil Pressure	Pressure is above setpoint or low oil pressure input is inactive	Pressure is below setpoint or low oil pressure input active	Fault code SPN 100 received AND ECU warning/shutdown active	No pressure data (ECU only)
High Engine Temperature	Temperature is below setpoint or high engine temperature input is inactive	Temperature is above setpoint or high engine temperature input is active	Fault code SPN 110 received AND ECU warning/shutdown active	No temperature data (ECU only)
Overspeed	Engine speed below overspeed setpoint	Engine speed above overspeed setpoint		No speed data (ECU) or loss of speed (non-ECU)
Underspeed	Engine speed above underspeed setpoint	Engine speed below underspeed setpoint		No speed data (ECU) or loss of speed (non-ECU)
Overcrank/Start Fail	Failure to start has not occurred	Overcrank start failure (crank attempts exceeded)	Start Condition Failure (RPM not below 10 or crank disconnect input is on before attempting crank)	Start Condition Failure (ECU-related) CAN Hw Bus Error preventing start
Charge Fail	Alternator warning lamp terminal voltage is above threshold or charge fail input is inactive	Alternator warning lamp terminal voltage is below threshold or charge fail input is active	Battery Voltage is below low voltage warning setpoint	Battery Voltage is above high voltage warning setpoint
Auxiliary 1	Auxiliary input 1 is inactive	Auxiliary input 1 is active	ECU Warning (malfunction or Amber lamps on)	ECU Shutdown (Red Stop or Protect lamps on)
Auxiliary 2	Auxiliary input 2 is inactive	Auxiliary input 2 is active	Weak Battery	

Table 3. Error Codes LED States

LED's	Value
ENGINE RUNNING	128 (MSB)
ECU STATUS	64
REMOTE START/CRANK REST	32
LOW OIL PRESSURE	16
HIGH ENGINE TEMPERATURE	8
OVERSPEED	4
UNDERSPEED	2
OVERCRANK/START FAIL	1 (LSB)
CHARGE FAIL	
AUXILIARY1	
AUXILIARY2	

Obtain the error code parameter by adding all lit LED's. See Table 1 for the corresponding parameter.

Table 4. Configuration Error Codes

The LEDs shown in the table below form an 8-bit binary error code to indicate the type of configuration error detected. The following error codes are currently defined:

Error Code(s)	LED Indication	Error
1 – 63	(varies)	Individual configuration parameter number is out of range. The number flashed indicates the configuration parameter number that is in error (see Table 1.)
128	●○○○○○○○	Configuration memory CRC error. The user will need to go back to configuration mode and resave at least one configuration parameter.
129	●○○○○○○●	All three digits of flywheel tooth count are zero. This is not allowed.
130	●○○○○○○○	Remote Start Signal Type is set to MOMENTARY but no auxiliary input is configured for MOMENTARY STOP.
131	●○○○○○○●	One of the Aux outputs is configured for "SPEED UP" or "SPEED DOWN" but none of the other Aux outputs is configured for the opposite setting
132	●○○○○●○○	Speed source is set to AC Frequency and Crank Disconnect Frequency is set to less than 10 Hz. Crank disconnect frequency must be greater than 10 Hz.
133	●○○○○●●○	Speed source set to Mag Pickup and Crank Disconnect RPM < 10 RPM. Crank disconnect RPM must be greater than 10 RPM.
134	●○○○○●●○	Run speed is less than or equal to crank disconnect RPM (non-genset engines)
135	●○○○○●●●	Extended pre-heat timer is longer than the crank timer.
136	●○○●○○○○	Speed source set to AC and crank disconnect setting is greater than nominal frequency.
137	●○○●○○●○	Low battery set point is greater than high battery set point.

In order to consistently bring you the highest quality, full featured products, we reserve the right to change our specifications and designs at any time. MURPHY products and the Murphy logo are registered and/or common law trademarks of Murphy Industries, LLC. This document, including textual matter and illustrations, is copyright protected by Murphy Industries, LLC, with all rights reserved. (c) 2010 Murphy Industries, LLC.

FW MURPHY

P.O. Box 470248
Tulsa, Oklahoma 74147 USA
Phone: +1 918 317 4100 Fax: +1 918 317 4266
E-mail: sales@fwmurphy.com

INDUSTRIAL PANEL DIVISION

Fax: +1 918 317 4124
E-mail: ipdsales@fwmurphy.com

MURPHY POWER IGNITION

Web site: www.murphy-pi.com

CONTROL SYSTEMS & SERVICES DIVISION

P.O. Box 1819
Rosenberg, Texas 77471 USA
Phone: +1 281 633 4500 Fax: +1 281 633 4588
E-mail: css-solutions@fwmurphy.com

FRANK W. MURPHY LTD.

Church Road, Laverstock
Salisbury, SP1 1QZ, UK
Phone: +44 1722 410055 Fax: +44 1722 410088
E-mail: sales@fwmurphy.co.uk
Web site: www.fwmurphy.co.uk

FW MURPHY INSTRUMENTS (HANGZHOU) CO., LTD.

77 23rd Street
Hangzhou Economic & Technological Development Area
Hangzhou, Zhejiang, 310018, China
Phone: +86 571 8788 8060 Fax: +86 571 8684 8878
E-mail: apsales@fwmurphy.com



COMPUTRONIC CONTROLS

41 - 46 Railway Terrace
Nechells, Birmingham, B7 5NG, UK
E-mail: sales@computroniccontrols.com
Web site: www.computroniccontrols.com



www.fwmurphy.com

05/05/2011