

SPECIFICATIONS

Four Stroke Cycle, Naturally-Aspirated, V8 Cylinder Diesel Engine.

Bore and Stroke	117 x 95 mm	4 ⁵ / ₈ in. x 3 ³ / ₄ in.
Displacement	8.3 L	504 cu. in.
Crankcase Oil Cap.	22 L	5.75 U.S. gals.
Engine Coolant Cap.	32 L	8.4 U.S. gals.
Net Weight with Std. Accessories, Dry	874 kg	1925 lbs.

INSTALLATION CONSIDERATIONS

Maximum raw water pressure must not exceed 345 kPa (50 PSI). Minimum acceptable raw water flow at 32° C (90° F.) raw water temperature and 38° C (100° F.) ambient air temperature should be at least 121 L/min. (32 GPM) at the 2200 RPM listed rating.

Ventilation air required for engine combustion is 149 L/sec. (265 CFM) at 2200 RPM rating. This is for engine air combustion only and does not take into consideration additional air required for normal room cooling.



This symbol on the nameplate means the product is Listed by Underwriters Laboratories Inc.



This symbol on the nameplate means the product is Listed by Underwriters Laboratories of Canada.

LISTED AGENCY RATINGS

116 HP @ 1750 RPM

135 H.P. @ 2000 RPM

145 H.P. @ 2200 RPM

All the above ratings are listed by the following agencies:

Underwriter's Laboratories

Underwriters' Laboratories of Canada

The agency-approved horsepower ratings published are already derated for fire pump service. The ratings show horsepower available for driving the fire pump at standard SAE J1349 conditions of 752 mm (29.61 in.) Hg barometer and 25°C (77°F) inlet air temperature (approximate 91.4 m [300 ft.] above sea level). The only additional deration necessary is for higher ambient temperatures and elevations as follows: 3% for each 305 m (1000 ft.) above 91.4 m (300 ft.) and 1% for each 5.6°C (10°F) above 25°C (77°F) in accordance with National Fire Association Pamphlet No. 20.

DESIGN FEATURES

Bearings: Replaceable, precision type, steel backed inserts.

Five main bearings, 89 mm (3.5 in.) diameter. Connecting rod bearings 70 mm (2.8 in.) diameter.

Camshaft: Single camshaft precisely controls valve and injector timing. Lobes are induction hardened for long life. Five replaceable precision type bushings 51 mm (2.0 in.) diameter.

Camshaft Followers: Induction hardened, roller type for long cam and follower life.

Connecting Rods: Drop forged, I-beam section 153 mm (6.0 in.) center to center length. Rifle drilled for pressure lubrication of piston pin. Rod is tapered on piston pin end to reduce unit pressures.

Cooling System: Belt driven centrifugal pump. Large volume water passages provide even flow of coolant around cylinder liners, valves, and injectors. Modulating by-pass thermostat regulates coolant temperature. Spin-on corrosion resistor checks rust and corrosion, controls acidity, and removes impurities.

Crankshaft: High tensile steel forging with induction hardened fillets and journals. Fully counterweighted and balanced.

Cylinder Block: Alloy cast iron with removable wet liners. Cross bolt support to main bearings cap provides extra strength and stability.

Cylinder Heads: Alloy cast iron. Each head serves three cylinders. Drilled fuel supply and return lines. Valve seats are replaceable corrosion resistant inserts. Valve guides and cross head guides are replaceable inserts.

Cylinder Liners: Replaceable wet liners dissipate heat faster than dry liners and are easily replaced without re boring the block.

Fuel System: Cummins exclusive low pressure PT™ system with wear compensating pump and integral dual flyweight governor. Camshaft actuated fuel injectors give accurate metering and precise timing. Fuel lines are internal drilled passages in cylinder heads. Spin-on fuel filter.

Gear Train: Timing gears and accessory drive gears are induction hardened spur gears driven from crankshaft and located at rear of block.

Lubrication: Large capacity gear pump provides pressure lubrication to all bearings. All pressure lines are internal drilled passages in block and heads. Oil cooler, full-flow filters maintain oil condition and maximize oil and engine life.

Pistons: Aluminum alloy, cam ground and barrel shaped to compensate for thermal expansion assures precise fit at operating temperatures. CeCorr™ grooved skirt finish provides superior lubrication. Two compression and one oil ring.

Piston Pins: Full floating, tubular steel retained by snap rings. 36 mm (1.4 in.) diameter.

Valves: 41 mm (1.6 in.) diameter poppet type intake and exhaust valves. Wear resistant face on exhaust valves.

STANDARD EQUIPMENT

Air Cleaner: 254 mm (10 in.) diameter, dry type mounted.

Belt and Damper Shield Guard: Protection from alternator, accessory drive, and water pump belts and vibration damper.

Coolant Pump: Belt driven, centrifugal type.

Corrosion Resistor: Fleetguard, mounted, checks rust and corrosion, controls acidity, and removes impurities from coolant.

Electrical Equipment: 24 volt negative ground system.

24 volt starting motor; 24 volt, 18 ampere alternator; voltage regulator; manually operable contracters; junction box with enclosed terminal strip.

Engine Support: Pedestal type, front and rear.

Exhaust Manifold: Water cooled.

Filters: Lubricating oil, full flow replaceable paper element, mounted. Fuel, paper element throwaway type, mounted.

Flywheel: Machined for stub shaft mounting.

Flywheel Housing: SAE No. 2 with industrial supports.

Governor: Mechanical flyweight, mechanical variable speed type.

Heat Exchanger: Tubular type, copper nickel.

Instrument Panel: Mounted. Includes ammeter, circuit breaker, water temperature gauge, tachometer, lube oil pressure gauge, hourmeter.

Lubricating Oil Cooler: Tubular type, jacket water cooled.

Oil Pan: Cast aluminum rear sump type, 18 litre (4.75 U.S. gallon) capacity. Provision for oil heater.

Oil Pressure Switch: Provides signal to activate alarm (not included) for low oil pressure.

Overspeed Switch: Mounted, overspeed shutdown with manual reset, stop crank contacts.

Stubshaft: Mounted on flywheel.

Vibration Damper: Rubber type.

Water Jacket Heater: Mounts under oil pan. 115 volt, 2500 watt. Thermostatically controlled.

Water Temperature Switch: Provides signal to activate alarm (not included) for high water temperature.

OPTIONAL EQUIPMENT

Oil Heater: Mounted in side of pan.

Cummins has always been a pioneer in product improvement. Thus specifications may change without notice. Illustrations may include optional equipment. See specific proposal bill of material for actual equipment being furnished.



Cummins Engine Company, Inc.
Columbus, IN 47202
U.S.A.

CUMMINS ENGINE COMPANY, INC.

Engine Data Sheet

Fire Pump Engine Model: V-504-F1
(for listed/approved ratings see tabulation)

Date: July, 1985

Data Sheet: DS-3607-C

General Engine Data

Type:	4-Cycle;90°Vee;8 Cylinder
Aspiration:	Natural
Bore — in. (mm)	4.625 (117)
Stroke — in. (mm)	3.75 (95)
Displacement — in. ³ (litre)	504 (8.3)
Compression Ratio:	17.0:1
Valves per Cylinder: — Intake	2
— Exhaust	2
Engine Weight & Center of Gravity (With Standard Accessories)	
Reference Installation Diagram	556880
Dry Weight — lb. (kg)	1925 (874)
Wet Weight — lb. (kg)	2045 (928)
C.G. Distance From F.F.O.B. — in. (mm)	14.4 (366)
C.G. Distance Above Crankshaft — in. (mm)	4.5 (114)
Maximum Allowable Bending Moment @ Rear Face of Block — lb.-ft. (N•m)	1000 (1 350)

Air Induction System

Maximum Allowable Temperature Rise Between Ambient Air and Engine Air Inlet (Ambients 32°F [0°C] to 100°F [38°C]) — °F (°C)	30 (15)
Maximum Allowable Intake Restriction With a Dirty Air Filter Element — in. H ₂ O (mm H ₂ O)	20 (500)
Part Number of Standard Air Filter Element (Dry Type)	555084

Lubrication System

Oil Pressure @ Rated Speeds — PSI (kPa)	45–70 (310–480)
Oil Flow @ Maximum Rated Speeds (Nominal) — U.S. GPM (litre/s)	25 (1.6)
Oil Pan Capacity (High — Low) U.S. gal. (litre)	4.75–4 (18–15)
Full Flow Lube Oil Filter Capacity — U.S. gal. (litre)	5.75 (22)
Part Number of Standard Oil Pan	554039
Part Number of Standard Oil Filter Element	LF-613

Application Note: When ambient temperatures will be lower than 70°F (21°C) an oil heater is required. The recommended heater wattage for this engine is 150 down to 40°F (4°C).

Cooling System

Heat Exchanger Cooled (Shell & Tube Type)	
Part Number of Tube Bundle	553747
Raw Water Working Pressure Range at Heat Exchanger — PSI (kPa)	50 (345) (Maximum)
Recommended Minimum Water Supply Pipe Size to Heat Exchanger (Reference Only) — in. (mm) dia.	1 (25)
Recommended Minimum Water Discharge Pipe Size From Heat Exchanger (Reference Only) — in. (mm) dia.	1.25 (30)
Coolant Water Capacity (Engine Side) — U.S. gal. (litre)	8.4 (32)
Standard Thermostat — Type	Modulating
— Range — °F (°C)	170–185 (77–85)
Minimum Raw Water Flow with Water Temperatures to 90°F (32°C) — U.S. GPM (litre/s)	32 (2.0)

Note: Minimum raw water requirement is based on water flow required to minimize tube fouling in the heat exchanger tube bundle.

A jacket water heater is mandatory on this engine. The recommended heater wattage is 1500 down to 40°F (4°C).

Exhaust System

Maximum Allowable Back Pressure Imposed by Piping & Silencer — in. Hg (mm Hg)	3 (75)
Exhaust Pipe Size Normally Acceptable — in. (mm) dia.	3 (75) Twin 4 (100) Single

Fuel System

Supply Line Size — in. (mm)	0.500 (15) I.D. Tube
Drain Line Size — in. (mm)	0.500 (15) I.D. Tube
Maximum Fuel Line Length Between Supply Tank & Fuel Pump — ft. (m)	40 (12)
Maximum Fuel Height Above Crankshaft — in. (mm)	80 (2 030)
Part Number of Standard Fuel Filter	156171
Part Number of Standard Fuel Filter Element	FF-105-D
Maximum Allowable Restriction to Fuel Pump With Dirty Filter — in. Hg (mm Hg)	8.0 (200)
Maximum Allowable Return Line Restriction — in. Hg (mmHg)	4 (100)

Electrical System

Battery Voltage	24	
Battery Cable Size (Maximum Cable Length Not to Exceed 10 ft. (3.0 m) AWG) ...	00	
Wiring for Automatic Starting (Negative Ground)	Standard	
Alternator (Standard) 24 Volt, Internally Regulated — Ampere	Standard	
Manually Operable Contactors	<u>Amp-hr.</u>	<u>°F CCA</u>
Minimum Recommended Battery Capacity —		
70°F (21°C) Minimum Temperature	100	450
32°F (0°C) Minimum Temperature	150	640
Reference Wiring Diagram Number	218147	

Performance Data

All data is based on the engine operating with fuel system water pump, lubricating oil pump, air cleaner, and alternator; not included are compressor, fan, optional equipment and driven components. Data represents gross engine performance capabilities obtained and corrected in accordance with SAE J1349 conditions of 29.61 in Hg (100 kPa) barometric pressure [300 ft. (90 m) altitude], 77°F (25°C) inlet air temperature, and 0.30 in Hg (1 kPa) water vapor pressure with No. 2 diesel fuel or a fuel corresponding to ASTM D2. All data is subject to change without notice.

Altitude Above Which Output Should be Limited — ft. (m)	500' (150m)
Correction Factor per 1000 ft. (300 m) above Altitude Limit	3%
Temperature Above Which Output Should be Limited — °F (°C)	85 (29)
Correction Factor per 10°F (11°C) Above Temperature Limit	1% (2%)

Listed/Approved Ratings BHP (kW)	Speed RPM	Ventilation Air Req'd. For Combustion CFM (litre/s)	Heat Rejection to Cooling Water BTU/min. (kW)	Heat Rejection to Ambient Air* BTU/min. (kW)	Exhaust Gas Flow CFM (litre/s)	Exhaust Gas Temp. °F (°C)	Fuel Consumption gal./hr. (litre/h)
147 (109)	2200	278 (131)	6405 (112)	639 (11.2)	651 (308)	825 (441)	7.4 (28.0)
136 (101)	2000	252 (119)	6090 (107)	613 (10.8)	588 (278)	840 (449)	7.1 (26.9)
117 (87)	1750	231 (109)	5250 (92)	535 (9.4)	536 (253)	820 (438)	6.2 (23.5)

*Does not include exhaust piping.

Fire Pump Engine Model: V-504-F1
 Data Sheet No.: DS-3607-C
 Date: July, 1985
 Bulletin No.: 3383361
 Rev.: 7/85

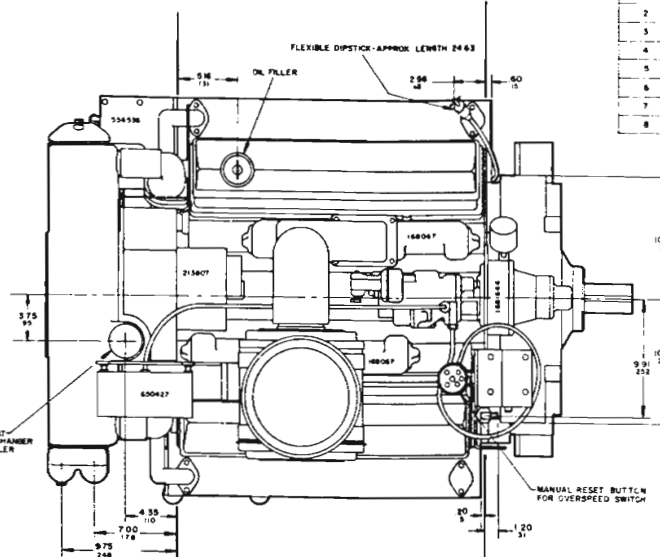
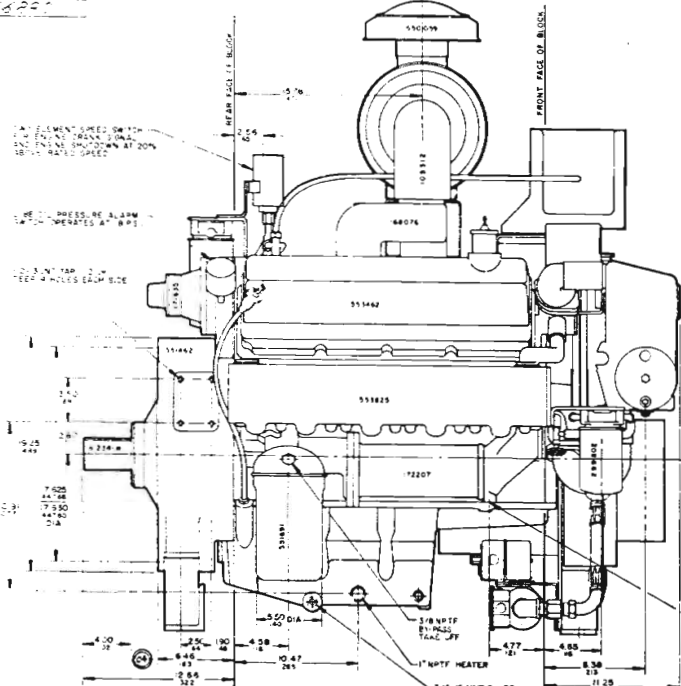

ITEM NO.	INSTRUMENT LIST	PART NO.
1	AMMETER (20 AMPS)	701213
2	CIRCUIT BREAKER	108102
3	GAUGE, WATER TEMP	556347
4	WARNING LAMP	556812
5	TACHOMETER	650072
6	BLANK	
7	GAUGE LUBE OIL PRESSURE	650651
8	HOURMETER	650525

NO.	DESCRIPTION	DATE	BY	CHKD.
1	ISSUED			
2	REVISION			
3	REVISION			
4	REVISION			
5	REVISION			
6	REVISION			
7	REVISION			
8	REVISION			
9	REVISION			
10	REVISION			

04 REV PER 772274

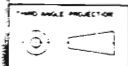
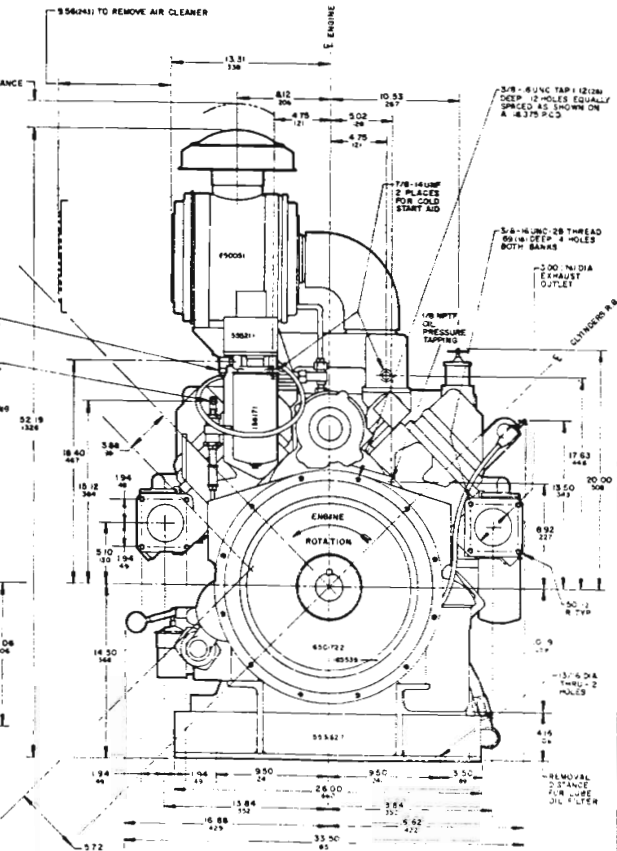
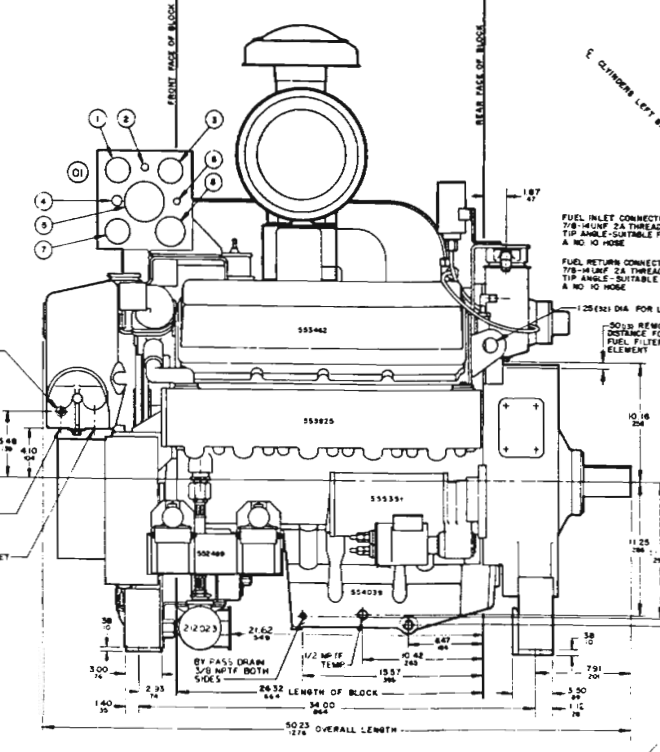
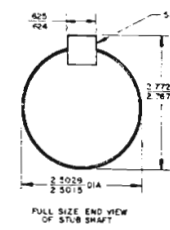

INCHES 1 2 3 4 5 6 7 8 9 10 11 12
MILLIMETERS 25 50 75 100 125 150 175 200 225 250 275 300

NOTE: ALL DIMENSIONS IN INCHES & MILLIMETERS DRAWN AT 1/4 SCALE

DO NOT SCALE DRAWING

CUMMINS ENGINE COMPANY, INC. RESERVES ALL RIGHTS TO THE DRAWING AND THE DATA THEREON WHICH IS SUBMITTED IN CONFIDENCE ONLY FOR QUOTATION OF ORDER BY CUMMINS ENGINE COMPANY INC. OR ITS PRODUCT KNOWLEDGE DEPARTMENT. DATA ARE NOT TO BE USED OR REPRODUCED FOR ANY OTHER PURPOSE WITHOUT THE CONSENT OF CUMMINS ENGINE COMPANY, INC.

DATE	APR 9 1975	CUMMINS ENGINE COMPANY, INC.
CHKD.		COLUMBUS, INDIANA
REV.		
APP'D.		INSTALLATION V-504 F1P2
APP'D.		DIA. RAM
APP'D.		E 556880
APPROVED		SCALE 1/4" = 1"