

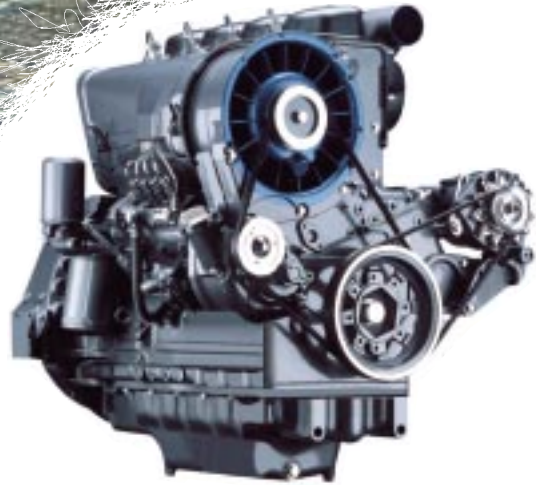

# 912. The engine for construction equipment.



24 - 82 kW at 1500 - 2500 min<sup>-1</sup>



## These are the characteristics of the 912:

- Air-cooled 3-, 4-, 5-, 6-cylinder naturally aspirated in-line-engines.
- Direct injection.
- Advanced injection and combustion system.
- PTOs via gear, V-belt and crankshaft.
- Extremely compact design.
- High torque at low speeds.
- Modular system with single cylinder arrangement and high degree of parts commonality.
- Customized component system with many different peripheral parts.
- Cold-starting ability even under extreme climatic conditions.

## These are the benefits for you:

- ▶ Fast response to load changes.
- ▶ Low noise emission, high cost savings thanks to less noise insulation requirement.
- ▶ Low operating costs thanks to lower fuel consumption and long maintenance intervals with reduced maintenance requirement.
- ▶ Excellent smooth-running characteristics thanks to low engine vibrations.
- ▶ Minimal environmental impact. Meets exhaust regulation EU-RL 97/68.
- ▶ Extremely reliable and durable.
- ▶ Easy-to-install unit (engine with integrated cooling system).

## Engine description

<b>Cooling system:</b>	Air-cooled with integrated axial-flow blower
<b>Crankcase:</b>	Grey cast iron
<b>Cylinder head:</b>	Aluminium single cylinder heads
<b>Valve arrangement/ timing:</b>	Overhead valves in the cylinder head, one inlet and one exhaust valve per cylinder, actuated from gear-driven camshaft via tappets, push-rods and rocker arms
<b>Piston:</b>	Three-ring piston: two compression rings and one oil scraper ring
<b>Piston cooling:</b>	Oil spray via nozzle
<b>Crankshaft:</b>	Drop-forged steel crankshaft with bolted counterweights
<b>Connecting rod:</b>	Drop-forged steel rod, diagonally split
<b>Main and big end bearings:</b>	Ready-to-install tri-metal plain bearings
<b>Camshaft:</b>	Steel, seated in bi-metal bearing on the blower side
<b>Lubrication system:</b>	Forced-feed circulation lubrication with rotary pump which feeds both lubricating and heating systems (if heating is fitted)
<b>Engine oil cooler:</b>	Integrated aluminium cooler
<b>Oil cooler thermostat:</b>	Oil cooler flow thermostatically controlled on engines with heating system
<b>Lube oil filter:</b>	Paper-type micro-filter as replaceable-cartridge full flow filter
<b>Injection pump/ governor:</b>	In-line injection pump with mechanical centrifugal governor
<b>Injection nozzle:</b>	Five-hole-nozzle
<b>Fuel filter:</b>	Replaceable cartridge
<b>Starter motor:</b>	12V; 2,7 kW (Standard)
<b>Alternator:</b>	Three-phase alternator, 14 V; 55A (Standard)
<b>Heating system:</b>	Optional connection for cab heating
<b>Options:</b>	Intake manifold connections, exhaust manifold connections, compressors, hydraulic pumps, engine mounts rigid and flexible, oil pans, SAE 1/2/3/4 flywheel housings, three-phase alternators 12 and 24 Volt, integrated hydraulic oil cooler, cooling fans controlled by exhaust thermostat

## ► Technical data

Engine type		F3L912	F4L912	F5L912	F6L912
Number of cylinders		3	4	5	6
Bore/stroke	mm	100/120	100/120	100/120	100/120
Displacement	l	2.83	3.77	4.71	5.66
Compression ratio		18	18	18	18
Max. rated speed	min <sup>-1</sup>	2500	2500	2500	2500
Mean piston speed	m/s	10	10	10	10
<b>Power ratings for construction equipment engines<sup>1)</sup></b>					
Power ratings for automotive engines <sup>2)</sup>	kW	40	54	68	82
at speed <sup>3)</sup>	min <sup>-1</sup>	2500	2500	2500	2500
Mean effective pressure	bar	6.79	6.88	6.93	6.96
<b>Power ratings for industrial engines<sup>4)</sup></b>					
highly intermittent operation	kW	40	54	68	82
at speed	min <sup>-1</sup>	2500	2500	2500	2500
Mean effective pressure	bar	6.79	6.88	6.93	6.96
intermittent operation <sup>4)</sup>	kW	38	51	65	78
at speed	min <sup>-1</sup>	2500	2500	2500	2500
Mean effective pressure	bar	6.45	6.50	6.62	6.62
Max. torque	Nm	185	247	308	370
at speed	min <sup>-1</sup>	1450	1450	1450	1450
Minimum idle speed	min <sup>-1</sup>	650	650	650	650
Specific fuel consumption <sup>5)</sup>	g/kWh	225	225	225	225
Weight to DIN 70020, Part 7A <sup>6)</sup>	kg	270	300	380	410

## ► Model designation

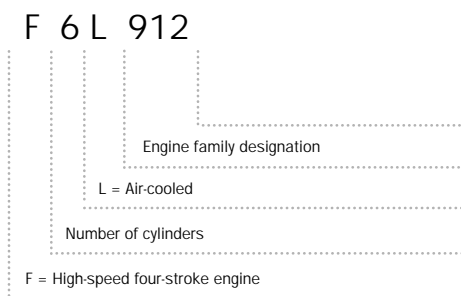

- 1) Power ratings without deduction fan power requirement, incl. cooling system, meeting exhaust emission limits of EU-RL 97/68.
- 2) Power ratings to DIN ISO 1585, EG-RL80/1269/EWG ECE-R 24
- 3) Power ratings for non-mentioned speeds upon request.
- 4) Power to DIN ISO 3046/1 (IFN). The fuel stop IFN power is an ISO net power at flywheel under reference conditions with all essential auxiliaries driven by the engine.
- 5) At optimal operating point. Specific fuel consumption based on diesel fuel with a specific gravity of 0,835 kg/dm<sup>3</sup> at 15°C.
- 6) Without starter motor/alternator, radiator and liquids, however with flywheel and flywheel housing and complete integrated cooling system.

The values given in this data sheet are for information purposes only and not binding. The information given in the offer is decisive.

## ► Standard engines

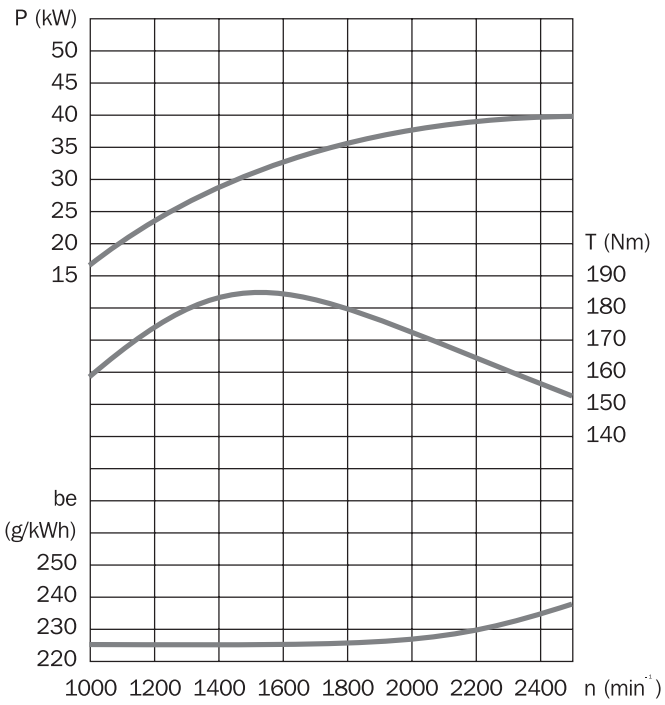

► F3L912

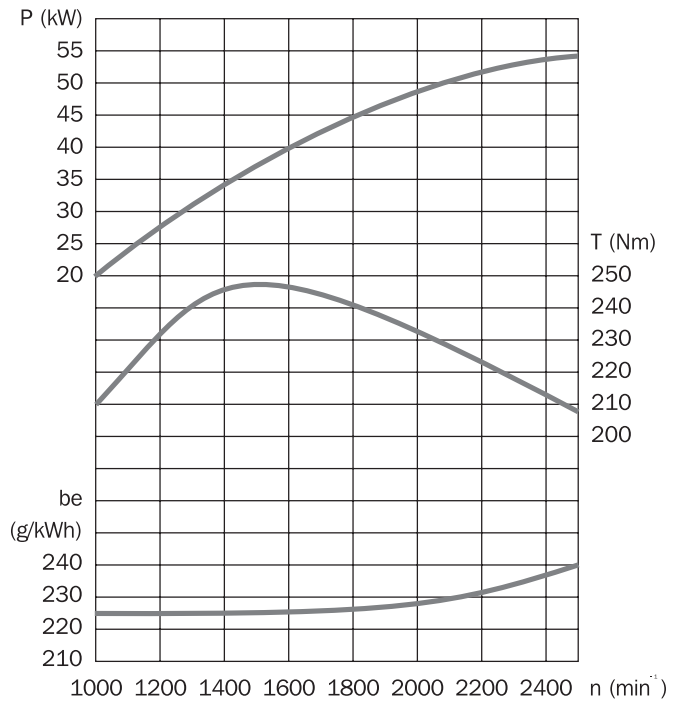

► F4L912

## ► Dimensions

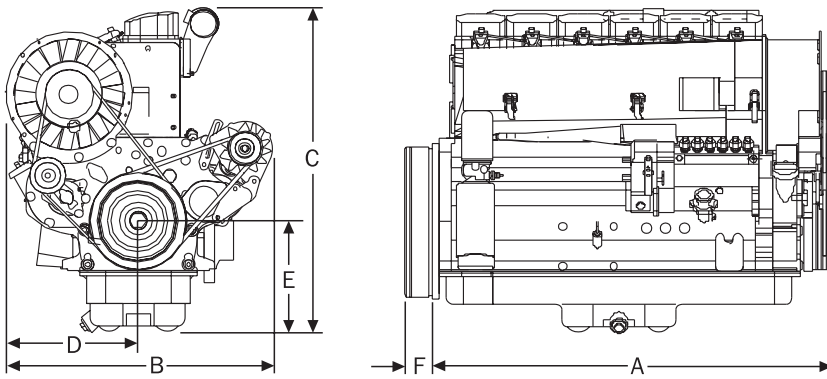

Engine		A	B	C	D	E	F
F3L912	mm	589	679	796	329	268	108
F4L912	mm	719	679	796	329	268	88
F5L912	mm	866	679	833	329	305	88
F6L912	mm	996	679	806	329	278	88

\*) with standard flywheel, incl. cooling system  
 \*\*) with standard oil pan, oil sump central

## ► Standard engines

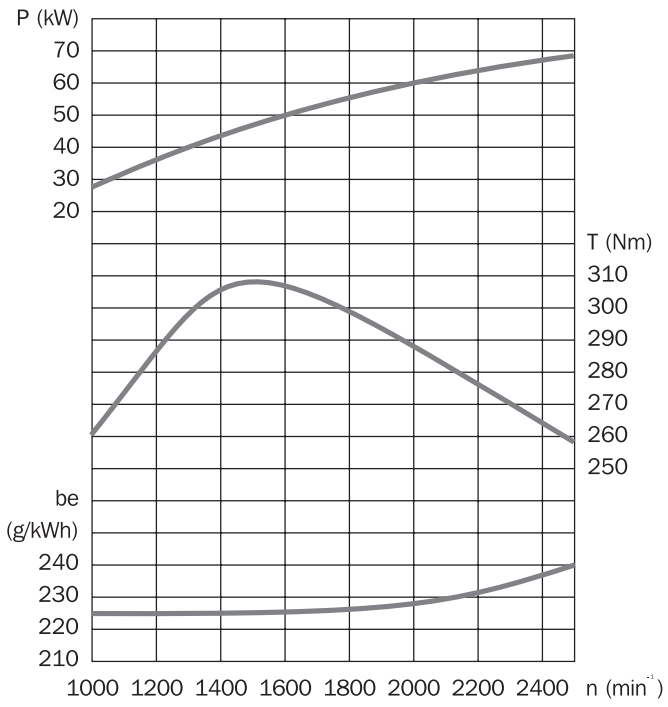

► F5L912

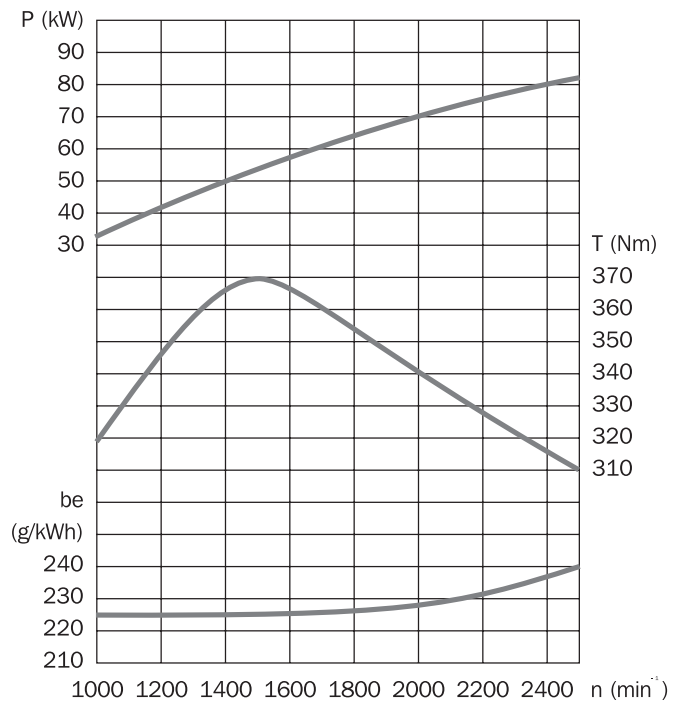

► F6L912

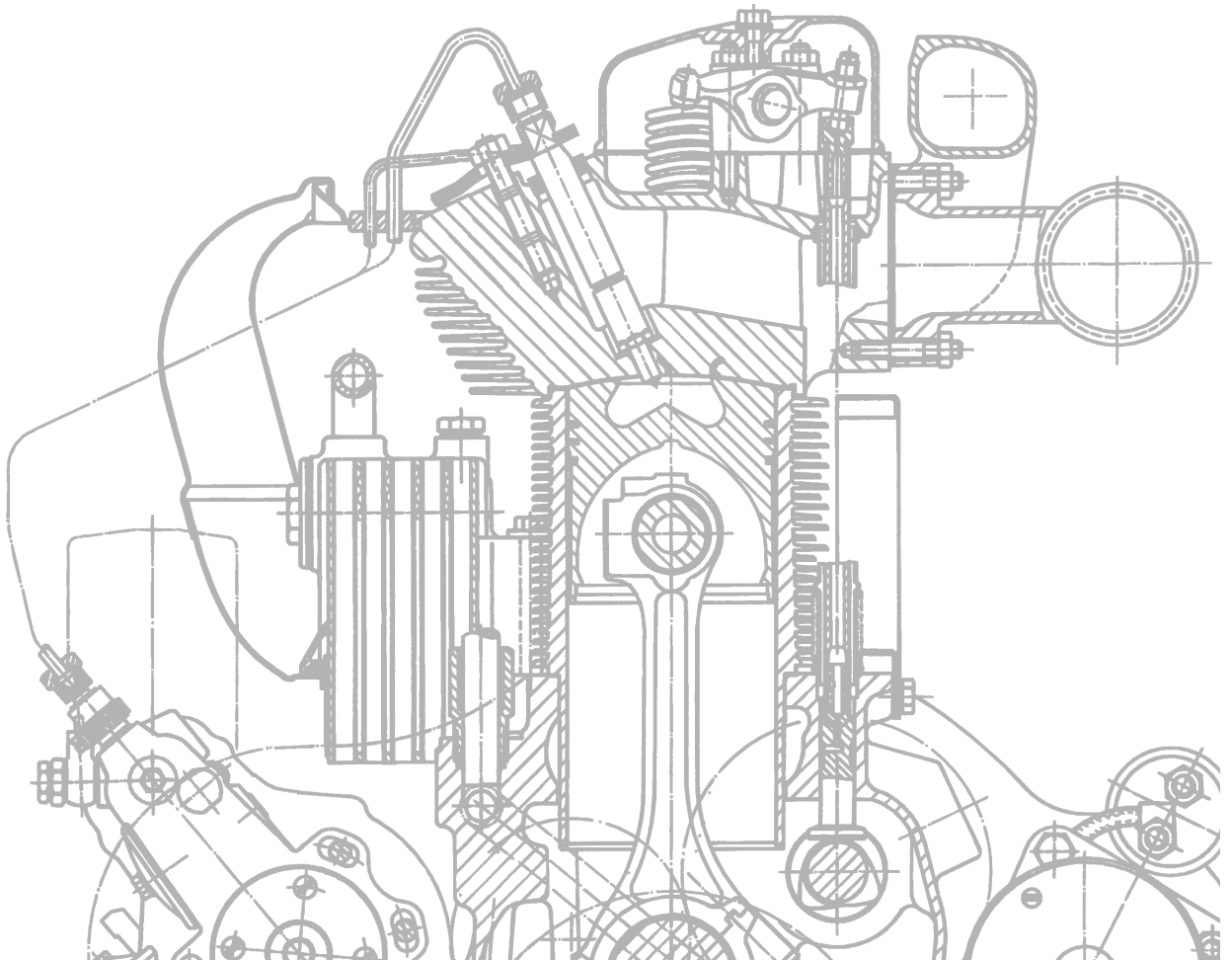



**Knowing it's DEUTZ.**

**DEUTZ AG**

Deutz-Mülheimer Str. 147-149

D-51057 Köln

Telephone: ++ 49 (0) 2 21-8 22 - 25 10

Fax: ++ 49 (0) 2 21-8 22 - 25 29

Internet: <http://www.deutz.de>