

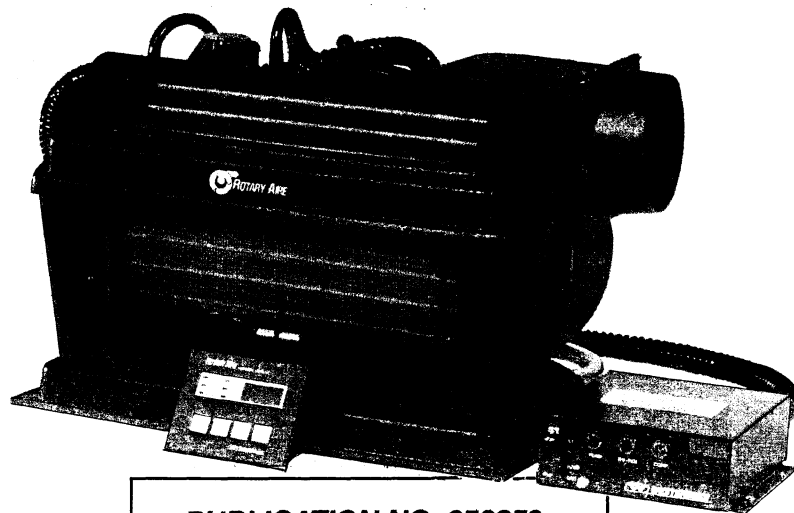

ROTARY AIRE

marine climate control system

OWNERS MANUAL PARTS AND SERVICE



PUBLICATION NO. 050259

REVISION 3

AUGUST 2013

WESTERBEKE

WESTERBEKE CORPORATION • MYLES STANDISH INDUSTRIAL PARK
150 JOHN HANCOCK ROAD • TAUNTON MA 02780-7319 • TEL. (508)823-7677
FAX (508)884-9688 • WEBSITE: WWW.WESTERBEKE.COM

 **NMMA** Member National Marine Manufacturers Association

SAFETY INSTRUCTIONS

INTRODUCTION

Most accidents are caused by failure to follow fundamental rules and precautions. Know when dangerous conditions exist and take the necessary precautions to protect yourself, your personnel, and your machinery.

*The following safety instructions are in compliance with the American Boat and Yacht Council (ABYC) standards.**

Read the manual carefully and thoroughly before attempting to operate the equipment. Know when dangerous conditions can exist and take necessary precautions to protect personnel and equipment.

PREVENT ELECTRIC SHOCK

- Do not operate this machinery without electrical enclosures and covers in place.
- Shut off electrical power before accessing electrical equipment.
- Use insulated mats whenever working on electrical equipment

* **ABYC** (American Boat and Yacht Council)
"Standards and Technical Information Reports for Small Craft"
Order from:
ABYC
613 Third Street, Suite 10
Annapolis, MD 21403
www.abycinc.org

- Make sure your clothing and skin are dry, not damp (particularly shoes) when handling electrical equipment.
- Remove wristwatch and all jewelry when working on electrical equipment.
- Electrical shock results from handling a charged capacitor. Discharge capacitor by shorting terminals together.
- Do not service the unit while the unit is running; if a situation arises in which it is absolutely necessary to make operating adjustments, use extreme care to avoid moving parts.
- Do not wear loose clothing or jewelry when servicing equipment; avoid wearing loose jackets, shirts or sleeves, rings, necklaces, or bracelets that might be caught in moving parts.

LIFTING AND INSTALLING

The main Rotary Aire unit is heavy. Take care when lifting and positioning the unit (10,000 BTU model weighs 55 lbs and the 17,000 BTU model weighs 63 lbs). **WESTERBEKE** recommends having two people to lift and position the unit when installing or removing.

 **WARNING: The discharge of unit refrigerant into the atmosphere is prohibited by Federal Law.**

TABLE OF CONTENTS

Rotary Aire Components	1
Product Software and Warranty	2
Operation Overview	3
Components and Accessories	4
Installation	5
Installation Check	7
Multiple Installations	7
Digital Thermostat Programming	8
System Operation	8
Digital Controller Programming	9
Troubleshooting Guide	13,14
Evacuating the System	15
Charging the System	16
Compression Checks	17
Capacitor Checks	18
Maintenance	18
Winterizing	18
Specification and Glossary	19
Wiring Diagram	20
Wiring Schematic	21
Main Assembly (Part Drawing/List)	22
Electrical Box (Part Drawing/List)	24
Accessories Parts List	25
Metric Conversions Formulas	27

ROTARY AIRE COMPONENTS

TOP VIEW

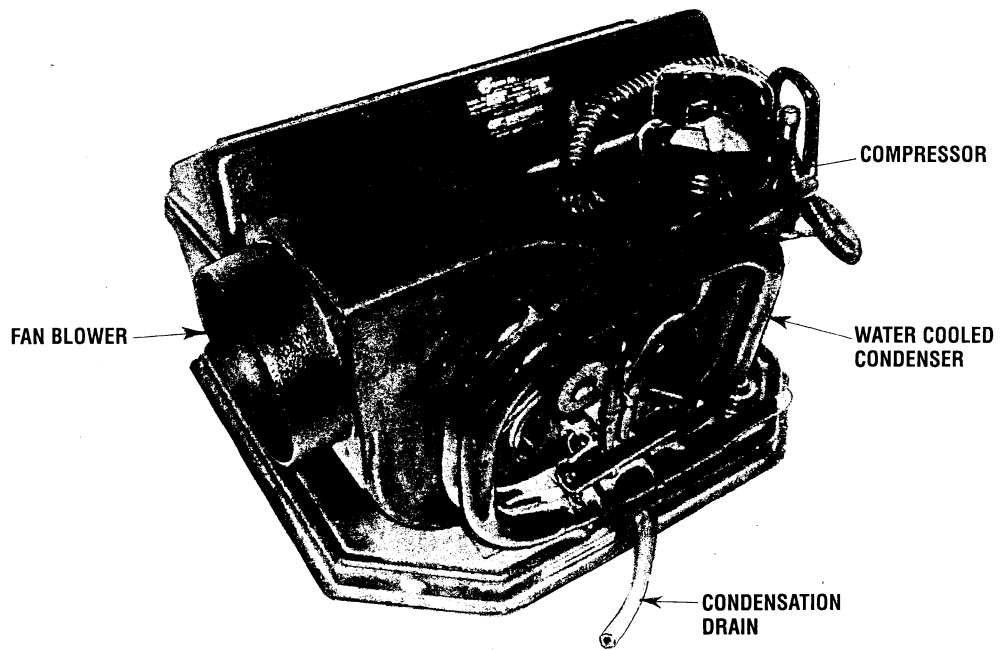
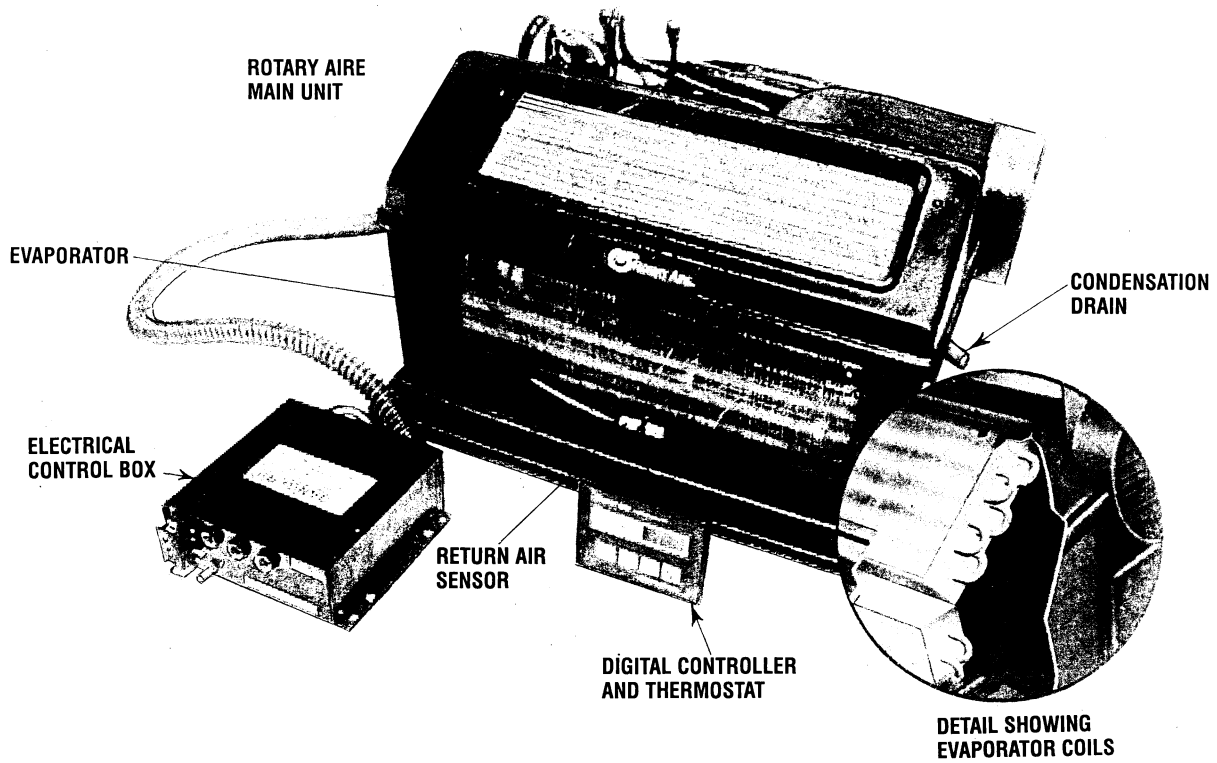

REAR VIEW

PRODUCT SOFTWARE INFORMATION AND WARRANTY

IMPORTANT

Product software of all kinds, such as brochures, drawings, technical data, operator's and workshop manuals, parts lists and parts price lists, and other information, instructions and specifications provided from sources other than Westerbeke, is not within Westerbeke's control and; accordingly, is provided to Westerbeke customers only as a courtesy and service. Westerbeke cannot be responsible for the content of such software, makes no warranties or representations with respect thereto, including the accuracy, timeliness or completeness thereof, and will in no event be liable for any type of damages or injury incurred in connection with, or arising out of, the furnishing or use of such software.

For example, components and subassemblies incorporated in Westerbeke's products and supplied by others (such as electrical components, pumps and other products) are generally supported by their manufacturers with their own software, and Westerbeke must depend on such software for the design of Westerbeke's own product software. Such software may be outdated and no longer accurate. Routine changes made by Westerbeke's suppliers, of which Westerbeke rarely has notice in advance, are frequently not reflected in the supplier's software until after such changes take place.

Westerbeke customers should also keep in mind the time span between printings of Westerbeke product software and the unavoidable existence of earlier, non-current, Westerbeke software editions in the field. Additionally, most Westerbeke products include customer-requested special features that frequently do not include complete documentation.

In summation, product software provided with Westerbeke products, whether from Westerbeke or other suppliers, must not and cannot be relied upon exclusively as the definitive authority on the respective product. It not only makes good sense but is imperative that appropriate representatives of Westerbeke or the supplier in question be consulted to determine the accuracy and currency of the product software being consulted by the customer.

LIMITED WARRANTY

Products manufactured by Rotary Aire are covered under limited warranty to be free from defects in workmanship and/or materials under normal use and service for a period of 24 months from the date of installation in after-markets installation. In the case of Boat Builder installation, the time period starts when the equipped boat is first received by the boat purchaser. The warranty card must be filled out and returned to Rotary Aire.

This Warranty does not apply to:

1. Damage or failure of Rotary Aire equipment due to abuse, neglect, misuse, fire, submergence, or acts of God.
2. Any part or parts which fail as a result of improper application or improper installation.
3. Inadequate cooling or heating capacity resulting from the selection of improperly sized units.
4. Damage caused by oversized circuit breakers or fuses, undersized or inadequate wiring, etc.
5. Component damage from improper (too high or too low) voltages.
6. Damage caused by improper or incomplete winterizing of Rotary Aire products.
7. Damage caused by lack of, or improper, periodic maintenance.

Your responsibility as an owner of Rotary Aire equipment is to contact a Rotary Aire factory authorized Service Dealer for authorization prior to having repair work performed.

The Rotary Aire 2 year limited warranty policy statement (revised) is continued at the back of this manual.

ROTARY AIRE OPERATION OVERVIEW

HOW THE ROTARY AIRE SYSTEM WORKS

An air conditioner works on the principle where cold is defined as the absence of heat. Basically, an air conditioner cools a designated space by transferring heat from one space to another.

The basic principle behind the function of most air conditioners is for fluids absorb heat when they evaporate (become gaseous) and give off heat when condensing back into a liquid form. An air conditioner contains sealed tubes through which a refrigerant is alternately vaporized and condensed, picking up heat in one place and releasing it in another in the process.

In normal home or office air conditioners, the heat is taken from the inside air, transferred through the refrigerant and released into the outside air. Air-to-air units, however, are not suitable for marine applications. There is usually no convenient place for installation of an air-to-air unit on board a vessel without punching a hole in the hull or superstructure. This would be inconvenient and unsightly. In addition, the outside components would be subject to salt air and would deteriorate rapidly. As a result, marine-type air conditioners are of the air-to-water type, transferring the heat inside the boat through the refrigerant into seawater, which is pumped through the system and then released overboard.

A Rotary Aire System consists of five basic mechanical components: a compressor, a condenser, an expansion device (capillary tubes), an evaporator and a reversing valve.

The refrigerant is drawn into the compressor in a gaseous state. Here it is pressurized to approximately 250 psi. The hot pressurized gaseous refrigerant then flows into the condenser. Seawater from outside the boat is piped through a tube physically located inside the refrigerant tube, cooling the refrigerant and converting it from a hot gas into a cooler liquid. The heat from the refrigerant is transferred into the seawater, and this warmed seawater is piped to an overboard discharge. The cool, high-pressure liquified refrigerant is piped to an expansion device (capillary tubes), which controls the rate at which it flows into the evaporator. A blower or fan moves warm, humid cabin air across the evaporator coils.

As the refrigerant flushes into a gas inside the evaporator coils, it absorbs heat from the compartment air. The refrigerant is then returned to the compressor, and the process continues until the temperature desired is achieved.

By adding a reversing valve in the piping system, it is possible to reverse the flow of refrigerant after it leaves the compressor, so hot gas flows first to the evaporator in the cabin and then to the condenser. In this way it is possible for the heat exchangers to change roles. The evaporator becomes a condenser, giving off heat to the cabin, and the condenser becomes an evaporator, absorbing heat from the seawater. This process is normally referred to as "reverse-cycling" and the unit as a "heat-pump" unit, capable of both heating and cooling.

COMPONENTS AND ACCESSORIES

REQUIREMENTS

- 1. Main Unit:** Compressor, evaporator coils, condenser coil, remote electrical box. Rotary Aire systems are equipped for reverse-cycle heat pump operation, providing both heating and cooling in a single unit.
- 2. Digital Display:** To ensure proper and efficient climate control.
- 3. A Water Pump** is required to provide a flow of water through the condenser. Two basic types are offered; centrifugal and rubber impeller/positive displacement. Centrifugal pumps are recommended whenever possible. Rubber impeller/positive displacement pumps are used only when the pump cannot be below the waterline. Water is piped to the pump from a scoop-like thru-hull fitting through a seacock and water strainer.
- 4. A Pump Relay** is used whenever two or more Rotary Aire systems are installed on one boat using a common water pump. There are two types: the RA-2 model relay can support two units, while the RA-6 relay can support up to six separate air conditioning units.
- 5. Ducting** is used to pipe air to the supply grills. Rotary Aire offers a wide variety of accessories to fit all applications.
- 6. Air Grill** supplies and returns are offered in a wide range of styles, in both teak and aluminum.

Raw Water Pumps

500 GPH, 1000 GPH; self-priming pumps are also available.

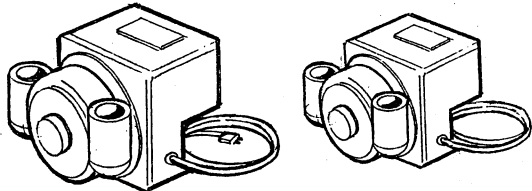

Part Number	Name	Remarks	Quantity
050021	Pump	Sea Water 500 GPH 110 VAC	1
050449	Pump	Sea Water 500 GPH 220 VAC 50 Hz	1
050294	Pump	Sea Water 500 GPH 220 VAC 60 Hz	1
050025	Kit	Fitting 500 GPH Water Pump	1
050394	Kit	Repair 500 GPH Water Pump	1
050022	Pump	Sea Water 1000 GPH 110 VAC	1
050452	Pump	Sea Water 1000 GPH 220 VAC 50 Hz	1
050363	Pump	Sea Water 1000 GPH 220 VAC 60 Hz	1
050269	Kit	Fitting 1000 GPH Water Pump	1
050395	Kit	Repair 1000 GPH Water Pump	1
050019	Pump	Sea Water 390 GPH 110 VAC	1
050391	Kit	Fitting 390 GPH Water Pump	1
050023	Pump	Sea Water 1000 GPH Sparkproof 110 VAC	1
050127	Strainer	Sea Water 3/4"	1
050270	Kit	Strainer Fitting	1
050015	Relay	Sea Water Pump, 2 Units	1
050016	Relay	Sea Water Pump 4-6 Units	1
050454	Padding	10,000 BTU Unit	1
050455	Padding	17,000 BTU Unit	1
050387	Filter Set	2 Each, 4 x 13-1/3" Filters	1
050388	Filter Set	2 Each, 7 x 15" Filters	1

ACCESSORIES

Supply Grills

4" round, and 4"x 4", 4"x 8", 4"x 10", 4"x 12", 5"x 10", 5"x 12", 6"x 12". Available in aluminum or teak, the above sizes are the most commonly used, almost any size is available in tan or black.

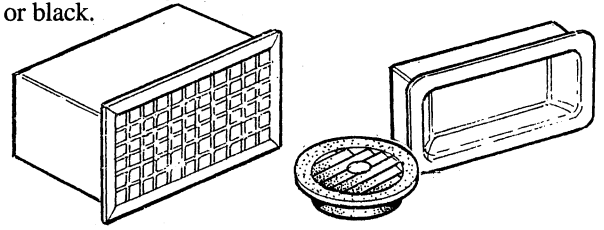

Transition (Plastic Vacuform) in sizes

4"x 4", 4"x 8", 4"x 10", 4"x 12", 5"x 10", 5"x 12", 6"x 12"

Distribution Ducting

"T" Junctions: 6"x 5"x 5", 6"x 6" x 4", 5"x 4"x 4";
"Y" Junctions: 5" x5", 5"x 4".



Ducting

4 inch, 5 inch, 6 inch

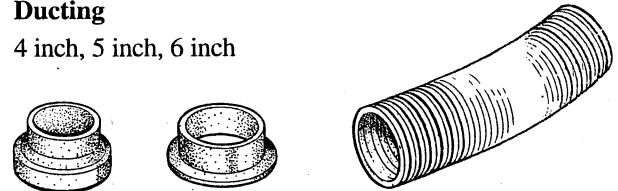

Hose Rings

4", 5", and 6"

Return Air Grills

10"x 14", 12"x 14", 9"x 16",
7"x 14" aluminum in tan or black.

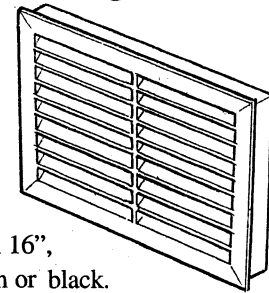

NOTE: Additional accessories such as insulation and extra lengths of digital cable are available from your Rotary Aire dealer.

INSTALLATION

WIRING AND CIRCUIT BREAKER SIZE

Unit BTU Capacity	Volts Wire Size	Breaker Size
10,000 BTU	1 15 Volts No. 10	20 - 30 Amp
17,000 BTU	1 15 Volts No. 10	20 - 30 Amp

1. Use proper wire size with a ground to feed the power from the ship's panel to the remote box terminal block and make sure that the ground wire is properly connected to the ground buss in the ship's distribution panel.
2. Ground the water pump and pump relay box, (if one is used) to the ground on the terminal board.
3. Check the continuity of the ground system with an ohmmeter (if available) before the Rotary Aire system is energized.

WARNING: To prevent a possible electrical shock which could result in serious injury or death, always ground the Rotary Aire system in the following manner.

NOTE: For ease of field servicing, Rotary Aire has implemented the use of a remote electronics box. This is to enable the service technician to be able to troubleshoot and diagnose the system should a problem should arise, in a more time-efficient manner than to replace the system.

INSTALLATION INSTRUCTIONS

1. Rotary Aire systems are designed for installation in a closet or under a dinette seat or bunk, etc. Do not locate any units in the engine room or any gasoline vapor areas.
2. The return air grill must be equal to the face of the evaporator coil (as a minimum), with discharge air ducted to a grill located high in the area to be cooled or heated.

NOTE: The unit must be installed so there is adequate path for air to circulate freely into the evaporator with a 4" minimum of clearance for proper air flow from the space being cooled or heated.

3. Supply grills require a transaction box fitted directly behind the grill. After determining the proper location for the hose ring, cut the appropriate size with a hole saw and attach flexible ducting to the ring with stainless steel screws and duct tape to keep air from escaping. Also note that the ducting should always be attached to unit Y's and T's and hose rings with stainless steel screws and duct tape, not hose clamps, as they may vibrate loose.
Minimum discharge:
50 square inches: 10,000 BTU,
70 square inches: 17,000 BTU.
4. The return air to the cooling unit should be filtered through a lint screen filter.
5. The remote electrical box may be mounted up to approximately 5 feet away from the main unit. It should be securely fastened to the bulkhead or deck.

NOTE: Properly ground all electrical components.

A PROPERLY DESIGNED ROTARY AIRE SYSTEM

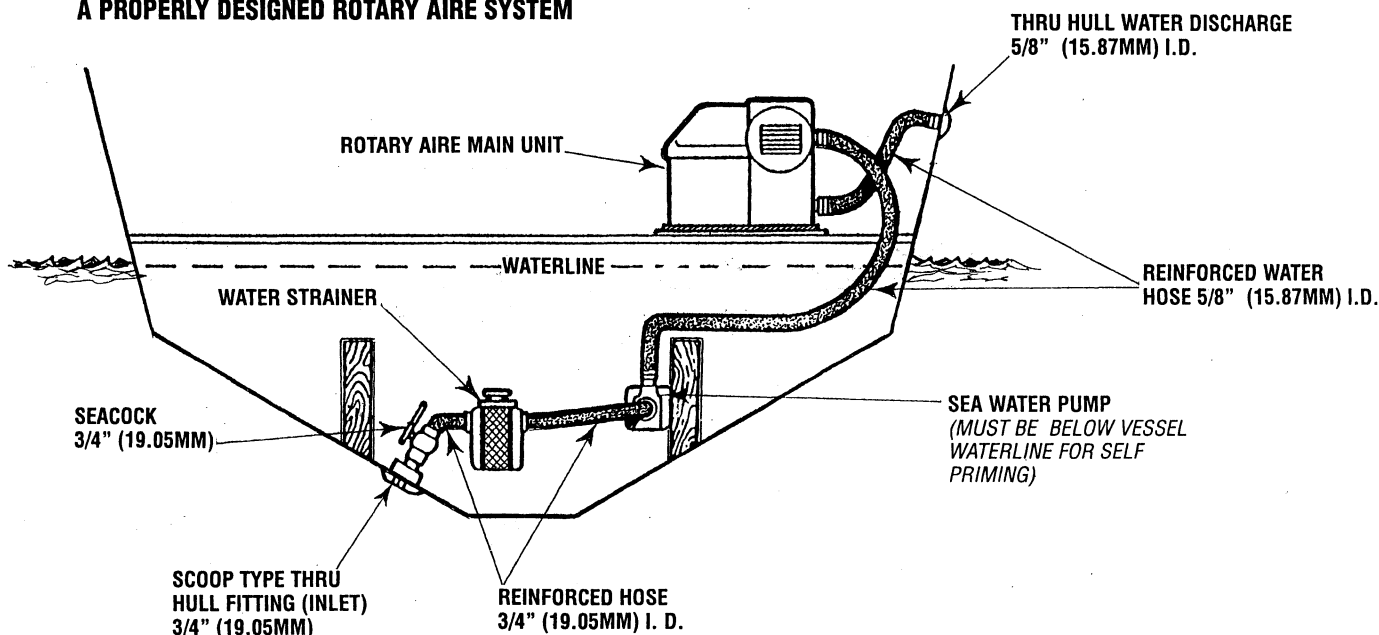

INSTALLATION (CONT.)

NOTE: Longer cables are available for special applications. The display cables can be router (but not twisted) around the IVC power wiring.

6. Water should be piped thru a scoop-type thru-hull fitting, a seacock and water strainer to a water pump (refer to manufacturer specifications). A separate thru-hull and seacock must be used; do not combine with any other water cooled systems. It is strongly recommended that you use a centrifugal-type pump and mount the pump well below the boat's water line. Unit waterlines should be routed continuously uphill from the thru-hull to your Rotary Aire system. Avoid loops or dips in all lines. If it is not possible to place the water pump below the water line, use a self-priming pump instead of a centrifugal pump.
7. Route the condensate drain so that it flows freely to an overboard fitting or sump. The drain must be installed so that the drain tubes make a continuous drop after leaving the drain fitting and must be routed from that point to continue downhill to a suitable location. The quantity of water involved on a hot, humid day may be as much as several pints per hour.

8. Use the check list provided to make sure your system is ready for operation before starting.

a) The digital display provides all of the function for operating the unit. Mount the display in a convenient location out of harms way where it can be operated and monitored as needed.

b) Remote/bridge units: The Air Temperature Sensor located on the Rotary Aire unit **must** be sensing the temperature of the air returning from the area the unit is cooling/heating. If this is not the case, the unit will not sense that the area it is cooling/heating has reached the temperature set on the display and continue to run (not cycle) and freeze up.

The temperature sensor on the unit **must** be relocated to the area that the unit is cooling/heating so that the unit will sense the temperature in that area and cycle accordingly.

NOTE: Failure to move the return air temperature sensor will result in the unit freezing up.

WARNING: Make certain you understand these installation instructions. Improper installation of Rotary Aire components could result in the flooding of your vessel. Contact Rotary Aire for clarification of instructions if necessary.

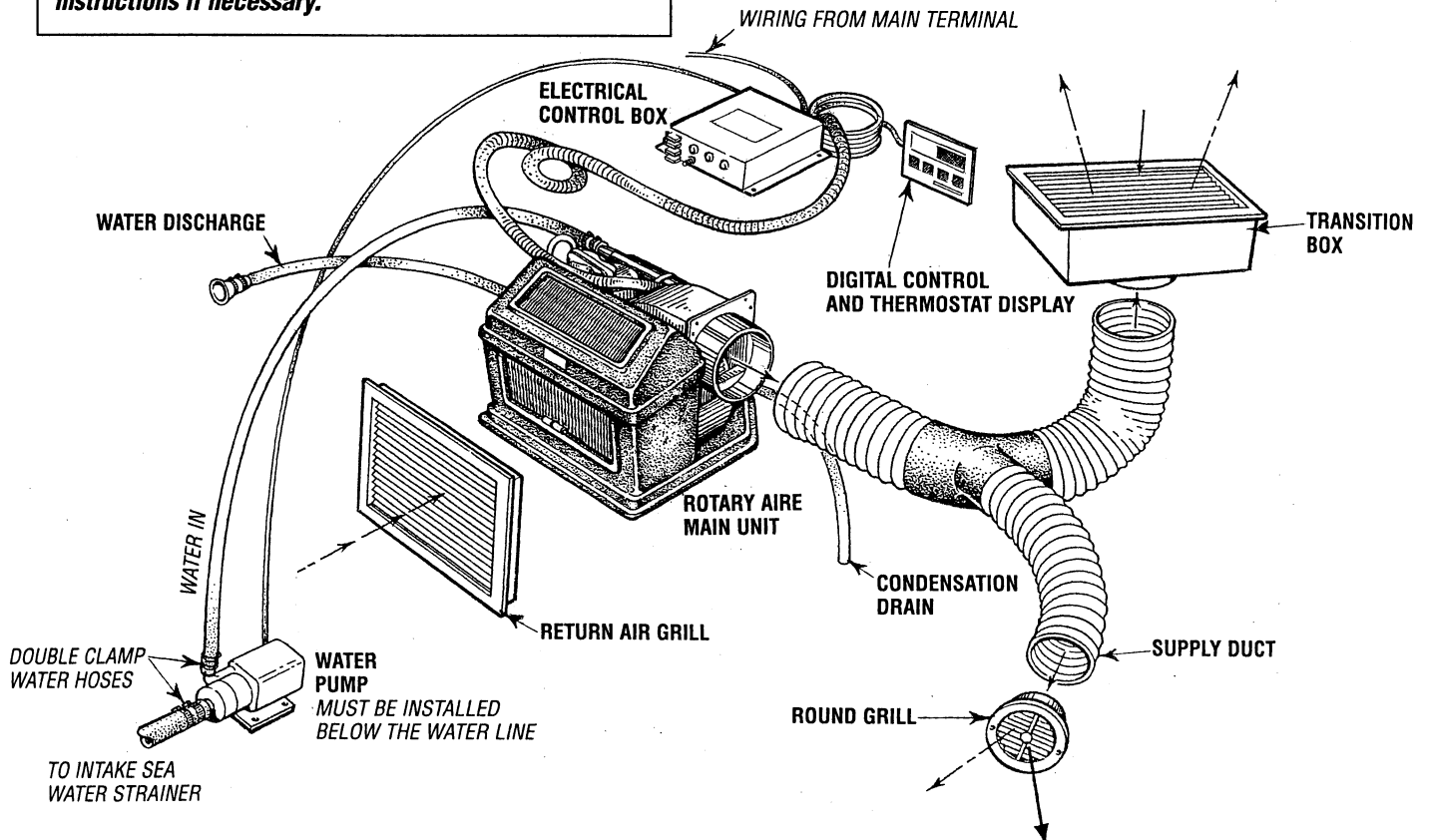

INSTALLATION CHECK LIST

CHECK LIST

Before operating your Rotary Aire system, carefully inspect the entire system for proper installation.

Ensure the following items have been checked before operating the Rotary Aire System:

1. The unit and all other components are fastened securely in place.
2. The return air grill area is equal to the face of the unit evaporator coil (as a minimum) and is filtered through a lint screen or similar.
3. The digital display can be mounted in any convenient location to monitor the unit and for system operation.
4. The condensate drain is in place and runs continuously downhill (test by pouring two quarts of water rapidly over the evaporators).
5. The water pump is installed **below** the water line (centrifugal type).
6. The water system is equipped with a seacock and strainer. Check that the seacock is open to allow water flow.

7. The inlet thru-hull fitting is no more than 6 inches from the keel, is ahead of the stuffing box, and aft of the forward engine bulkhead.
8. Overboard water discharge for each unit is located so the water flow can be visually checked.
9. The water hoses are wire reinforced hose and double-clamped.
10. The power line from the ship's panel is connected securely and properly grounded to the electrical box. Make certain proper size breakers and correct wire gauge is used.
11. The pump or pump relay box (if used) wires are connected to the terminal strip in the remote box and grounded.
12. The ductwork is properly sized and installed (see installation instruction). Check system back pressure at the discharge of the unit. .8 inches of water (.02 PSI) or less at #6 fan speed must be maintained for proper system operation.

MULTIPLE SYSTEM INSTALLATIONS

Water Pump Relay

Installations involving more than one Rotary Aire climate control system can utilize a solid state water pump relay. This enables one water pump of adequate size to supply up to six systems. Two models of the pump relay are available. Part #050015 is utilized for two (2) systems and Part #050016 is utilized for three to six systems.

Rotary Aire solid state pump relays should be used whenever possible. However, some replacement installations may already have a pump relay installed

NOTE: Pump relays must be installed with a separate power feed from the main power panel to assure proper operation. A 15amp breaker is recommended for circuit protection.

NOTE: Do not supply power to the pump relay from one of the climate control systems. Doing so will not allow the pump relay to operate unless the system it is connected to is powered up. This could result in no water flow to the other system or systems.

See the following diagram for the digital controls for proper pump relay wiring.

CAUTION: Do not utilize electromechanical type pump relays, as the switching characteristics are too slow to be compatible with solid state controls. Mechanical type pump relays are incompatible with Rotary Aire digital controls.

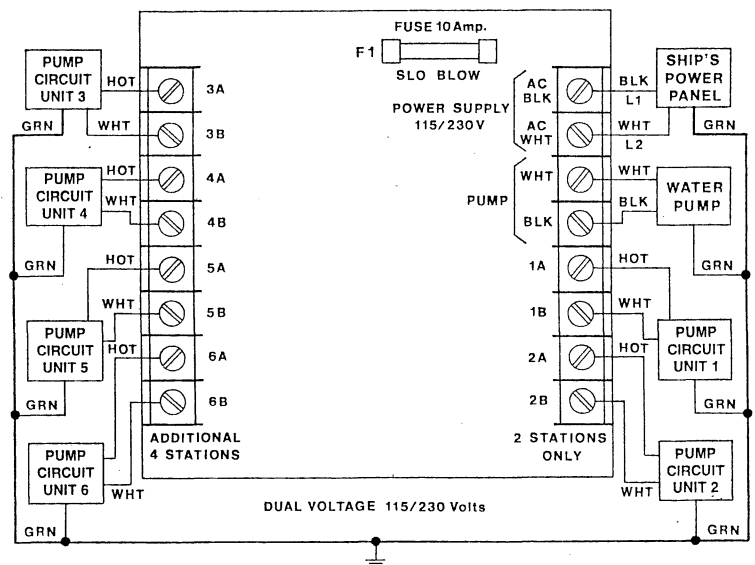

DIGITAL THERMOSTAT PROGRAMMING

NOTE: Ensure the air conditioner's main power supply breaker on the ship's panel is off before servicing or checking.

NOTE: Do not plug in or unplug any of the connectors or cables while the power is on. Doing so can damage the display circuitry in the module.

Field Programmable Features

In order to access some of the programmable functions, you will need to enter a password by setting the temperature at 85° F.

Learning the Controller

The four buttons on the display are used to program more than just the basic system operation. They can also be used in pairs so that you can do additional programming if you push two buttons at once, engaging "dual button functions."

- a. Basic Operation.
- b. Fan Speeds.
- c. Low Voltage Threshold and Compressor Delay.
- d. Humidity Mode.
- e. High Water Limit.
- g. Cycle Fan with Compressor.
- h. Display Fahrenheit of Celsius.

Basic Operation

- a. Push the ON/OFF button to engage the system. The control indicates room temperature.
- b. Set the desired temperature using "UP" and "DOWN" buttons. You can set your room temperature by pressing and holding either the "UP" or "DOWN" button.
- c. Select any of six fan speeds by pressing the fan button. The fan will start at full speed, indicated by a "six" on the display. If you continue to hold the button, the speed will count down 5, 4, 3, 2, 1. When you release the button, the fan will operate at that speed. The fan light indicates a manual fan speed has been selected. An "A" in the display indicates automatic operation in which case the fan speed is regulated depending on the temperature difference between set point and actual temperatures. When in automatic mode, the fan light will not be lit.

NOTE: It is not recommended that the unit be run in heating or cooling with a fan speed lower than 3. Be sure to readjust set point to the desired temperature after any programming.

Factory Settings

Low Voltage Threshold	100 volts
Compressor Delay	.60 seconds
High Water Limit	135 °F
Cycle Fan with Compressor	.0
Display Fahrenheit or Celsius	.0

SYSTEM OPERATION (Factory Settings)

Standard system operation when the **POWER** button on the display is momentarily depressed to turn the unit **ON**.

1. Fan will not turn **ON**. The Display will show the temperature of the air at the return inlet.
2. Cool or Heat LED on Display will illuminate depending on temperature.
3. Approximately 25-30 seconds an audible click from the unit will be heard at the unit indicating the water pump relay has activated the water pump.
4. 10-15 seconds the compressor relay will close cycling the compressor. The compressor will run either in the cool or heat mode until the temperature set on the Display is satisfied.
5. The compressor will cycle **OFF**. The Pump and Fan will continue to operate.
6. When the temperature at the return air inlet falls about 3-4 degrees from the temperature set on the Display, the unit will cycle and heat or cool until the set temperature is satisfied.

NOTE: Do not use the main AC circuit breaker that supplies AC voltage to the unit as the means of turning the unit **ON** and **OFF**. Use the **POWER** button on the Display to perform this function.

Turn **OFF** the AC breaker only after turning the unit **OFF** using the **POWER** button. Turn the AC breaker back to **ON**. Then turn the unit **ON** using the **POWER** button. Failure to follow this procedure may result in damage to components on the unit's PC Control Board due to a voltage surge.

DIGITAL CONTROLLER PROGRAMMING

Single Button Functions, System On

Used for Basic Operation

NOTE: When the system is OFF, you can push the FAN button and operate the fan only, providing ventilation but not cooling or heating.

Single Button Functions, System On or Off

While pressing the FAN button the numbers 6, 5, 4, 3, 2, 1, then A for automatic will appear in the display window. Six represents the highest and one represents the lowest fan speed. The fan light will turn on when one of the manual fan speeds is selected. The fan light will not be lit when the system is in automatic fan mode.

When the system is OFF, the fan can be used for circulation only by pressing the FAN button and selecting one of the six manual fan speeds. The fan light will remain on while in the circulation mode.

Auto Fan Speeds in Cooling Mode

1. - High fan speed when the temperature is four degrees or more above the set point.
2. - Medium fan when the temperature is within two degrees of the set point.
3. - Low fan speed when the temperature is satisfied or at the set point and the compressor cycles off.

Auto Fan Speeds in Heating Mode

1. - Medium fan speed when the temperature is four degrees or more below the set point.
2. - High Fan speed when the temperature is within two degrees of the set point.
3. - Low fan speed when the temperature is satisfied or at the set point and the compressor cycles off.

Single Button Functions, System Off

Used for program changes; system must first be set at 85° and then turned off in order to make program changes (other than fan operation).

Example:

Procedure to change compressor delay from normal factory setting. When ever the compressor is cycled off, it will remain off for the programmed delay time (set in seconds).

1. If system is not on, press POWER and engage system.
2. Press UP button and raise system to 85°.
3. Press POWER again to turn the system OFF.
4. Press the DOWN button and the display will indicate the delay time in seconds. If you hold the button down, the display will scroll through a selection of times from 15 to 90 seconds. Simply stop the scroll at the desired time.
5. Push the POWER button to return to normal operation.
6. Push the DOWN button to re-adjust the set point to a desired room temperature.

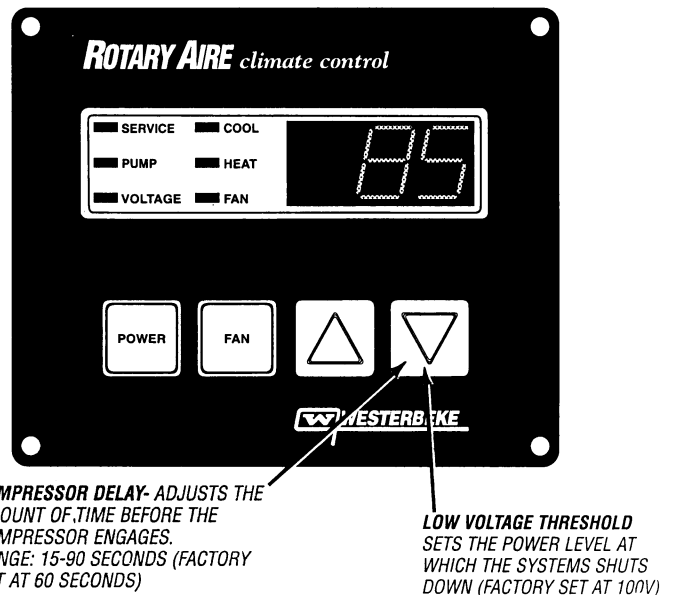
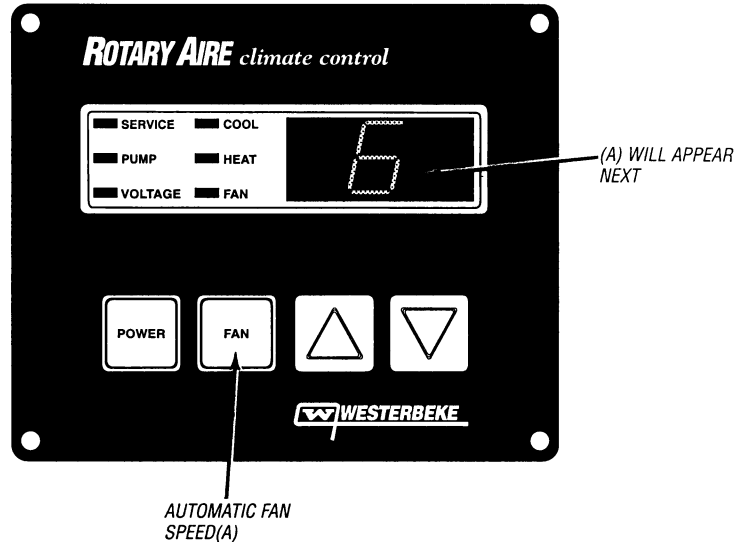
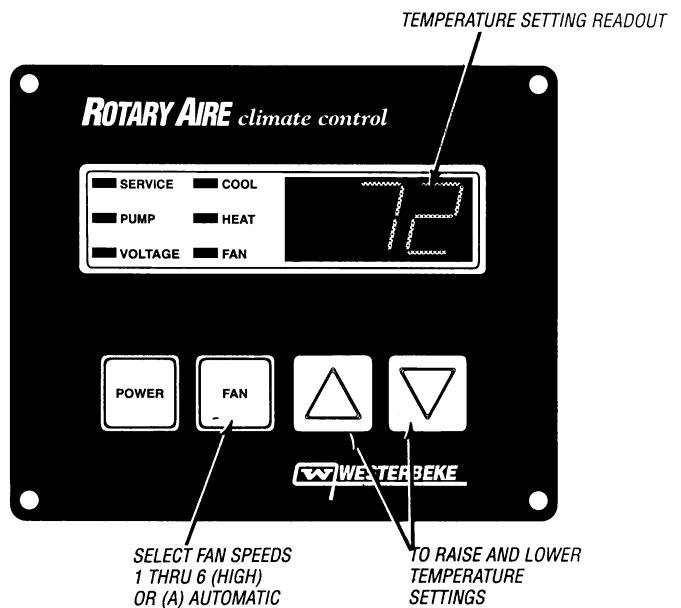

DIGITAL CONTROLLER PROGRAMMING

Dual Button Functions, System On

To adjust the high sea water temperature limit, you must first raise the set point temperature to 85°F.

Power must remain on.

Pressing the POWER and DOWN buttons together will display the numbers 120 through 145. Each number represents one degree fahrenheit, the lowest temperature being 120° fahrenheit and the highest temperature is 145° fahrenheit. (The factory setting is 135° F).

These temperatures represent the high and low limits of the high water sensor.

The high water limit is factory set at 135° fahrenheit.

Most systems operate around 125°F with 80°F sea water.

High engine room ambient temperatures or very warm sea water may require the high water limit to be set at 140 or 145°F.

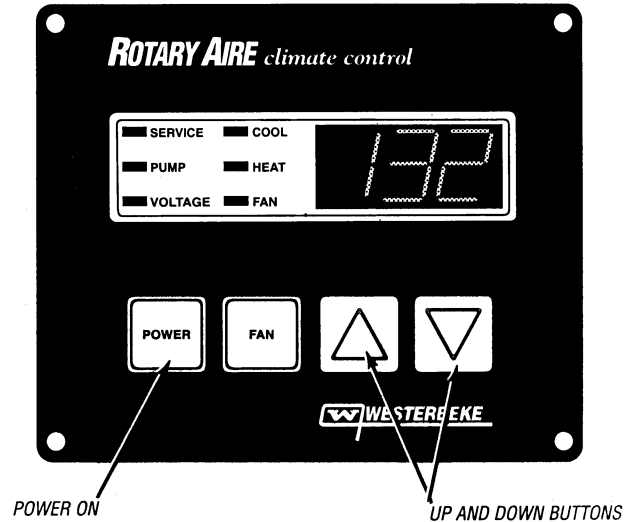

Cycle Fan With Compressor

To cycle fan with compressor, turn ON system.

Raise Set Point to 85°F.

turn off system.

Press the POWER and the DOWN button together.

The display will show:

1 = Fan cycles with compressor

0 = Fan operates normally (Factory Setting).

Dual Button Functions, System Off

The factory setting is zero (0), allowing the fan to run normally.

Pressing the DOWN and POWER button together will cause a one (1) or zero (0) to appear in the center digit of the display window.

Setting a one (1) in the display will allow the fan to cycle with the compressor.

Setting a zero (0) in the display will program the fan to run normally when the system is on.

After programming the fan cycle, turn on the system and return the set point to the desired temperature.

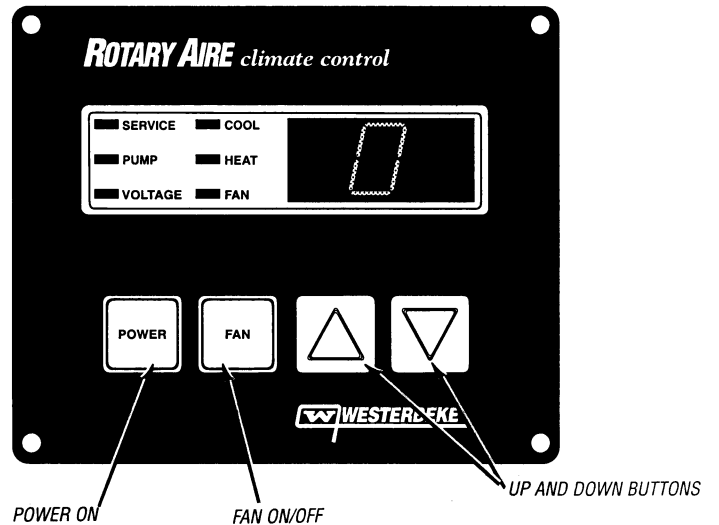

Dual Button Functions, System Off

The factory setting is for fahrenheit display.

After selecting fahrenheit or celsius, turn ON the unit and adjust the set point to the desired temperature.

- Zero (0) displays fahrenheit.

- One (1) displays celsius.

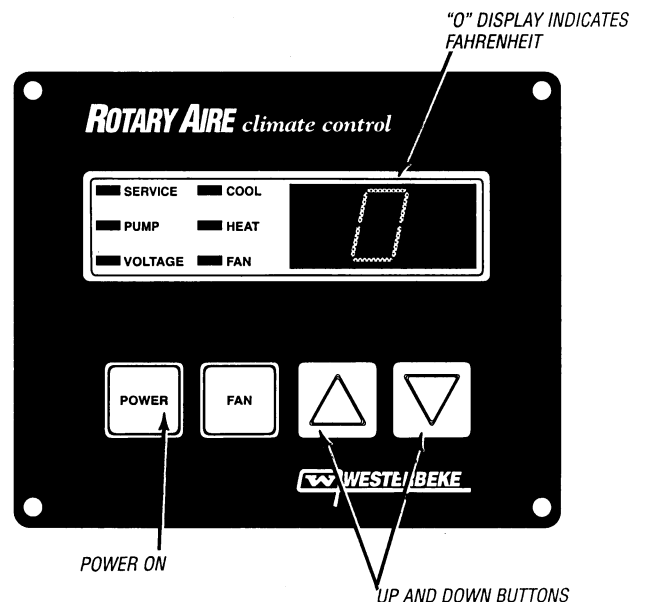

DIGITAL CONTROLLER PROGRAMMING

Display Fahrenheit Or Celsius

Turn the system **ON** and raise the set point to 85° F.

Turn the system **OFF**.

To select fahrenheit or celsius readings on the display, press the **FAN** and **UP** buttons together.

The display will show a one (1) for celsius readings.

The display will show a zero (0) for fahrenheit readings.

Humidity Mode

Turn on the unit by pressing the **POWER** button.

Set the **FAN** to manual high speed number six or place the fan in automatic.

To select one of the three humidity levels proceed as follows:.

Press **FAN** and **UP** button together and hold until humidity level #1 (11U1) shows on the display. Then release buttons.

For humidity level #2 (11U2). Press and hold **FAN** and **UP** buttons together and hold until humidity level 11U2 shows on the display, then release buttons.

For humidity level #3 (11U3), repeat the above procedure.

Pressing the power button cancels the humidity cycle and returns the system to the off mode.

Once you are in the humidity mode no other push buttons function. None of the lights function except the 11U1, 2, or 3 as shown in the illustration.

All fail safes are fully operational to protect the system. Should a voltage or pump problem occur, the system will shut down until the next cycle.

On boats equipped with more than one system, the programmed step start delays will prevent electrical overload. Each humidity cycle will be delayed by the amount of start delay programmed into the unit. The operator should program a different compressor delay for each system on board.

Calibrating Display Temperature Reading

The temperature shown on the display can be calibrated to adjust for any errors in the true temperature of the air entering the unit from the compartment which the system is operating in.

The temperature on the display can be calibrated +9° or - 9°.

Turn the system **ON** by pressing the **POWER** button.

Set the Display temperature at 85°. Then turn the system **OFF** by depressing the **POWER** button.

Depress the **POWER** and temperature **UP** button at the same time and hold them depressed.

The display will show zero (0) and the progress from 1° up to 9°.

(This is calibrating the temperature up as much as 9°). The display will then change and show -9° and progress down to -1°.

(This is calibrating the temperature reading down as much as 9°). Release both buttons when you have reached the number of degrees you want to calibrate the temperature on the display up or down.

Turn the unit **ON** and allow it to operate.

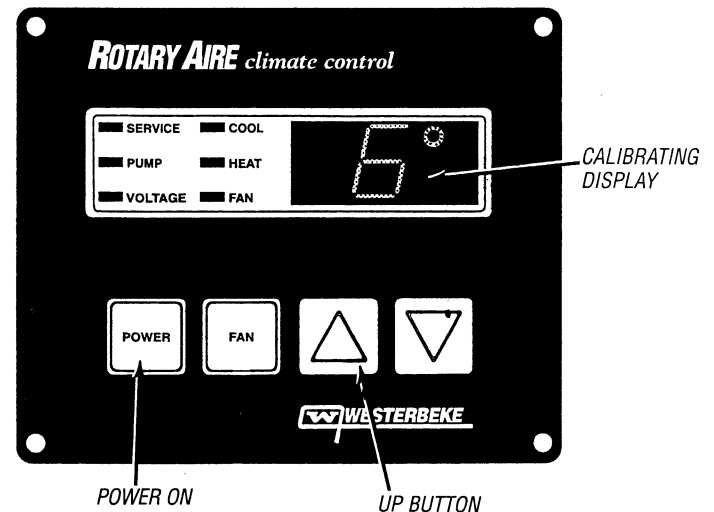
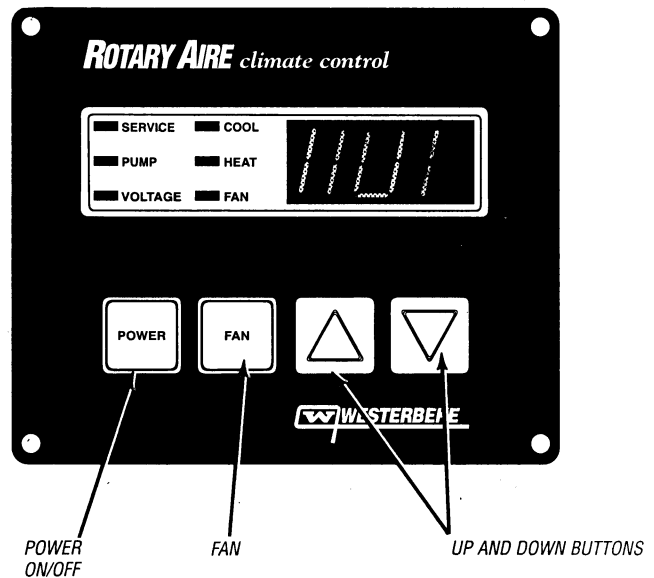
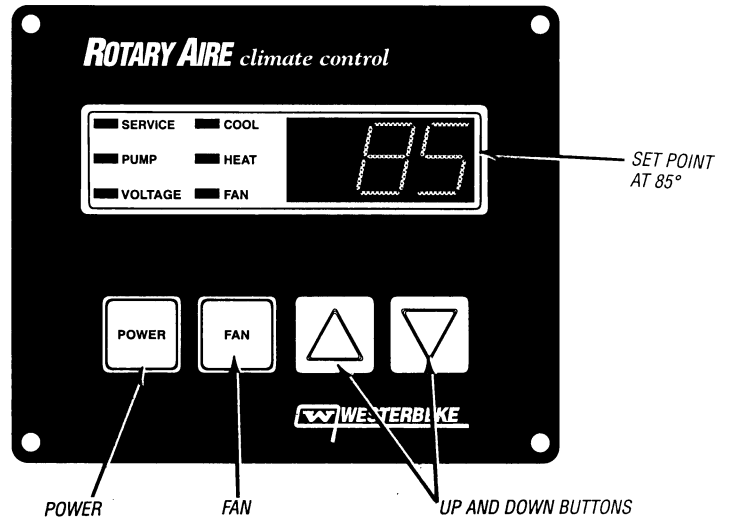

DIGITAL CONTROLLER PROGRAMMING

HUMIDITY MODE OPERATION

Humidity control operates every four-and-one-half hours plus the step starting delay. Upon entering the humidity mode, the compressor, fan, and pump will cycle off. At the end of four-and-one-half hours, the fan will start and run for thirty (30) minutes. The room temperature is then sampled and remembered. The compressor will cycle on and cool until the temperature is lowered by two degrees. The system will cycle off until the next humidity cycle, which will be four-and-one-half hours later.

Humidity level two will reduce the temperature by four degrees fahrenheit. Level three will reduce the temperature by six degrees fahrenheit. The humidity cycle will not function if the room temperature is sixty (60°) degrees fahrenheit or less.

Prior to entering the humidity mode, the fan can be programmed for automatic or manual operation.

A fan speed-setting of three or higher should be selected if a manual fan is used.

No fan speed adjustment is required if the automatic mode is selected.

No other adjustments can be made when the unit is in the humidity mode.

SETTING THE LOW VOLTAGE THRESHOLD

Turn the unit on by pressing the power button. Use the up/down buttons to set the display at 85° F.

Press the power button to turn the unit off. Press the up button-the display will show 90, 95, and then 100. (This corresponds to the factory setting of 100 VAC). When setting for 230V applications, multiply the number by 2.

LED LIGHTS

The **SERVICE** LED will illuminate when the control board assembly in the control box receives a signal from the temperature sensor on the condenser that the condensers temperature is at the factory setting.

The **PUMP** LED will illuminate when the control board assembly receives a signal from the temperature sensor on the condenser that the condenser temperature is above limits indicating there is no raw water coolant flow through the condenser.

The **VOLTAGE** LED will illuminate when system operating voltage falls below the low voltage threshold threshold that is factory set at 100 volts.

The **COOL** LED will illuminate when the unit is operating in the cooling mode.

The **HEAT** LED will illuminate when the unit is operating in the heating mode.

The **FAN** LED will illuminate when the fan circuit is activated for air circulation mode (only when the unit is powered off, no heat or cooling mode).

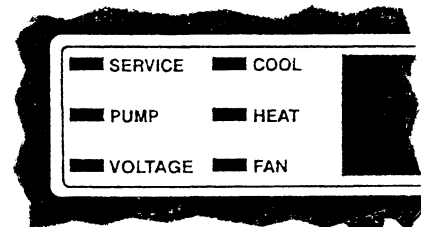
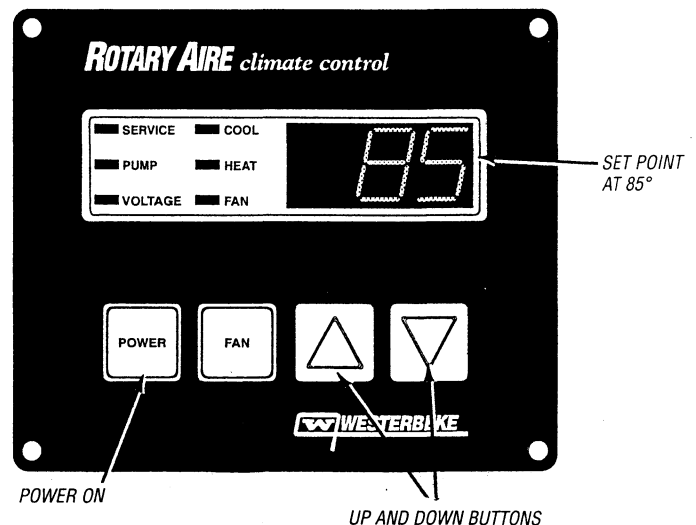
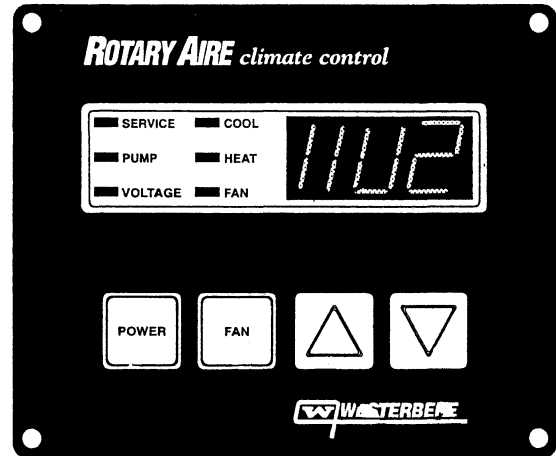

DIGITAL TROUBLESHOOTING GUIDE

These instructions on troubleshooting are a guide for problems that could develop in the Rotary Aire system. It is to be understood that these tests should be accomplished by a qualified refrigeration technician only. The following are a few tools that may be necessary to accomplish these tests:

**Manifold Gauge Set
Assortment of Hand Tools
Refrigerant R-22**

**Thermometers (2)
Multimeter
Leak Detector**

**Vacuum Pump (with extension cord)
Amprobe**

Problem	Probable Cause	Verification/Remedy
Unit will not start.	<ol style="list-style-type: none"> 1. Check the power. 2. Jumpers or wires in the control box are loose. 	<ol style="list-style-type: none"> 1. Check the wiring and reset the breakers. 2. Check and tighten.
Fan runs but the compressor will not start.	<ol style="list-style-type: none"> 1. Low voltage. 2. High compressor discharge pressure. 3. Compressor thermal overload protector. 4. Start components. 5. Relay. 6. Compressor failure. 	<ol style="list-style-type: none"> 1. Check input voltage to unit. 2. Check for improper raw water flow/restrictions. 3. Wait for reset, then try to restart, check protector. 4. Test capacitors, start assist and motor run. 5. Check compressor. 6. Wiring, check compressor.
Compressor runs but fan will not run.	<ol style="list-style-type: none"> 1. Faulty wiring. 2. Fan binding in shroud. 	<ol style="list-style-type: none"> 1. Check wiring and fan capacitor. 2. Check for free movement.
Unit running but not cooling enough.	<ol style="list-style-type: none"> 1. Display. 2. Restricted air flow. 3. Unit too small for application. 4. Refrigerant charge. 	<ol style="list-style-type: none"> 1. Check display for proper temperature setting. 2. Check return air filters and louvers for obstruction and restriction to evaporator. 3. Improperly sized unit for application. 4. Check and adjust.
Unit running but not heating enough.	<ol style="list-style-type: none"> 1. Display. 2. Reversing valve. 3. Air and water temperature. 4. Unit too small for application. 5. Refrigerant charge. 	<ol style="list-style-type: none"> 1. Check display for proper setting. 2. Be sure the valve has engaged. 3. See the pressure/temperature chart. 4. Improperly sized unit for application. 5. Check and adjust.
Unit short cycling. (compressor turning on and off)	<ol style="list-style-type: none"> 1. Display. 2. Restricted air flow 3. High compressor discharge pressure. 4. Compressor overload. 5. Condensate drain not functioning. 	<ol style="list-style-type: none"> 1. Check display for proper location and setting. 2. Check the return air supply filter and louvers. 3. Check for improper raw water flow/restrictions. 4. Check the voltage and test. 5. See if drain is functioning.
Noisy operation.	<ol style="list-style-type: none"> 1. Unit not securely mounted. 2. Refrigerant line rubbing. 3. Fan binding on shroud. 4. Noisy compressor. 	<ol style="list-style-type: none"> 1. Check and correct. 2. Check and realign. 3. Check and realign. 4. Allow for compressor run-in time. Call factory.
High running amperage.	<ol style="list-style-type: none"> 1. Water flow. 2. Incorrect wire size (shore power) 3. Restricted air flow. 4. Low voltage. 5. Refrigerant charge. 	<ol style="list-style-type: none"> 1. Check for improper water flow and restriction. 2. Check the wiring for correct rating. 3. Check the filters and louvers for obstructions. 4. Check the input power source. 5. Check the charge and adjust.
Low compressor suction pressure.	<ol style="list-style-type: none"> 1. Restricted air flow. 2. Refrigerant charge. 	<ol style="list-style-type: none"> 1. Check filters and louvers for obstructions. 2. Check and adjust.
High compressor discharge pressure	<ol style="list-style-type: none"> 1. Water flow. 2. Refrigerant charge. 	<ol style="list-style-type: none"> 1. Check for improper water flow/restrictions. 2. Check and adjust.
System leaking water.	<ol style="list-style-type: none"> 1. Condensate drain. 	<ol style="list-style-type: none"> 1. Make sure the hose is free from obstruction and installed correctly-continuous downhill routing with no loops or kinks in hose.
Compressor stays running after switching display to OFF position.	<ol style="list-style-type: none"> 1. Defective PC board. 	<ol style="list-style-type: none"> 1. Replace the PC board
No lights on the display and the cool system does not heat or cool.	<ol style="list-style-type: none"> 1. AC circuit breaker not turned on. 2. Eight conductor display cable plug or receptacle is loose. 	<ol style="list-style-type: none"> 1. Check the dock power with a voltmeter. 2. Make sure the display cables are making a good connection.
The display reads zero and the compressor will not run.	<ol style="list-style-type: none"> 1. The return air sensor is not plugged in. 2. The display open circuit return air sensor has an open circuit. 	<ol style="list-style-type: none"> 1. Check the connection. 2. Plug the coil temp. cable into the air temp. If the display reads the coil temp., the air temp sensor is faulty-replace. If the display reads zero, the PC board is faulty-replace.
The unit operates but the compressor will not run and there is no heat or cool light or the heating or cooling light is on but the compressor does not run.	<ol style="list-style-type: none"> 1. The temperature is not set properly. 2. The compressor breaker is tripped. 	<ol style="list-style-type: none"> 1. Raise or lower the set point. 2. Check and reset the breaker.

DIGITAL THERMOSTAT TROUBLESHOOTING GUIDE

Problem	Probable Cause	Verification/Remedy
No lights on the display and the system does not heat or cool.	<ol style="list-style-type: none"> 1. AC circuit breaker not turned on. 2. Blown one (1) of the one amp fuses. 3. Eight conductor display cable plug or receptacle. 	<ol style="list-style-type: none"> 1. Turn breaker on. 2. Replace the one (1) amp fuse. 3. Make sure display cables are making a good connection.
The display reads zero and the compressor will not run.	<ol style="list-style-type: none"> 1. The air sensor is not working or not plugged in. 2. The display sensor is not working. 3. The alternate air sensor is not working. 4. The control module is defective. 	<ol style="list-style-type: none"> 1. Determine which air sensor you are using. 2. If using the air sensor in the face plate, check the display cable, plugs and jacks. 3. Try another display cable. 4. If using the alternate air sensor, unplug it. If the system works, the sensor is bad. Return the module for repair.
The unit operates but the compressor will not run and there is no heat or cool light or the heating or cooling light is on but the compressor does not run	<ol style="list-style-type: none"> 1. The temperature is not set properly. 2. Tripped reset breaker. 3. Blown thirty (30) amp fuse. 	<ol style="list-style-type: none"> 1. Raise or lower the set point. 2. Check reset breaker. 3. Replace thirty (30) amp fuse.
When set to cycle with the compressor, the pump continues to run for two (2) minutes after the compressor cycles off.	<ol style="list-style-type: none"> 1. This is normal operation. 	<ol style="list-style-type: none"> 1. A valid water temperature is being taken for use with the service light functions.
The pump light is on and the compressor won't run.	<ol style="list-style-type: none"> 1. No water and pump is not running. 	<ol style="list-style-type: none"> 1. Check the pump fuse on the module. 2. Check the pump fuse on the pump relay (H used) 3. Check the pump circuit breaker. 4. Clean the strainer and bleed the air out of the system.
The pump light is on but you have water.	<ol style="list-style-type: none"> 1. Not enough water. 2. Water limit set improperly. 3. Defective sensor. 	<ol style="list-style-type: none"> 1. Clean the strainer or repair the pump. 2. Reprogram the water limit. 3. Obtain another sensor.
The compressor won't run and you have just repaired the pump or cleaned the water strainer.	<ol style="list-style-type: none"> 1. Tripped breaker. 2. Blown thirty (30) amp fuse. 3. Air in the system. 4. Relay. 	<ol style="list-style-type: none"> 1. Reset breaker. 2. Replace thirty (30) amp fuse. 3. Bleed the water system. 4. Check the relay.
The fan does not run manually or automatically or you replaced the fuse and it blows again.	<ol style="list-style-type: none"> 1. Blown 6 1/4 amp slo-blo fuse. 2. Bad fan capacitor. 3. Loose wire or connector. 	<ol style="list-style-type: none"> 1. Replace the fuse. 2. Check and replace the capacitor. 3. Check the fan circuit.
Fan light is on.	<ol style="list-style-type: none"> 1. This is not a problem. One of six (6) manual speeds has been selected. 	<ol style="list-style-type: none"> 1. Read the fan operating instructions.
The voltage light is on when using shore power.	<ol style="list-style-type: none"> 1. Low dock voltage. 2. Defective shore cord. 3. Defective shore power outlet. 	<ol style="list-style-type: none"> 1. Check the dock power with a voltmeter. 2. Try another cord. 3. Try another outlet.
The voltage light is on when using the ship's generator.	<ol style="list-style-type: none"> 1. The generator is not working properly. 2. Too much load for the generator. 	<ol style="list-style-type: none"> 1. Check the generators AC output. 2. Reduce the load on the generator.
The service light turns on after 1/2 hour of operation and stays on until the compressor cycles off.	<ol style="list-style-type: none"> 1. Not enough cooling water. 2. The system is low on refrigerant. 3. Service sensor. 4. Improper air flow. 	<ol style="list-style-type: none"> 1. Clean the raw water strainer and check the pump. 2. Charge the system with refrigerant. 3. Check the programming of the service sensor. 4. Check the return air grill and clean.
The ship's breakers trip when switching from shore power to generator or generator to shore power.	<ol style="list-style-type: none"> 1. The compressor delay is not long enough or set properly for multi-unit systems. 	<ol style="list-style-type: none"> 1. Reprogram each compressor delay progressively higher (i.e.: 15, 30, 45 seconds, etc.). See the single button functions when system is off for instructions
Thermostat does not respond/erroneous display.	<ol style="list-style-type: none"> 1. Thermostat cable. 2. Defective control module. 	<ol style="list-style-type: none"> 1. Make sure cables are making a good connection. 2. Replace module.
Unit cycles too frequently/pump continues to run.	<ol style="list-style-type: none"> 1. System pressure is too high or low. 2. Defective safety switch. 	<ol style="list-style-type: none"> 1. Check charge. 2. Check overload protector and high pressure switch.
Unit cycles too frequently/pump cycles also. Pump lights comes "ON."	<ol style="list-style-type: none"> 1. Service sensor on condenser mounted too close to compressor discharge line. 2. Defective service sensor. 3. High water temperature not set correctly. 	<ol style="list-style-type: none"> 1. Move sensor away from discharge line. 2. Replace sensor. 3. Reprogram correct limit.
All zeros or ones on Display, no LEDs.	<ol style="list-style-type: none"> 1. Faulty cable or connections between Display and Unit. 2. Faulty PC Control Board. 	<ol style="list-style-type: none"> 1. Check cable connections and cable for damage. 2. Replace PC Control Board.

EVACUATING THE SYSTEM

Diagnostics

When troubleshooting, refer to the pressure/temp chart for the correct refrigerant pressures. If the chart indicates a lack of refrigerant, this is an indication that there may be a leak. Be sure the leak is repaired before adding any refrigerant.

A Rotary Aire unit may need refrigerant if there is:

1. A partially frosted evaporator (or ice formation on the condensor).
2. Low discharge pressure (refer to the Cooling Cycle Chart).
3. Low suction pressure (refer to the Cooling Cycle Chart).
4. A leak.
5. The unit is not cycling (on or off) or not cooling. (The unit runs constantly but not enough or no cooling is produced).

Evacuation

1. Connect the service manifold and gauges to the vacuum pump by the center hose on the manifold.
2. The low-side hose connects to the low-side of the system. (Line off of the bottom of compressor).
3. The high-side hose connects to the high-side of the system. (Line off top of compressor)

NOTE: The service connection lines must be clean and free of air (which has moisture). This cleaning can be done by purging refrigerant through the lines before evacuating and charging. Ensure the system does not have any pressure in it when the vacuum pump is being attached. Any pressure in the system can cause the removal of oil from the vacuum pump.

4. Open both valves on the manifold.
5. Turn on vacuum pump. The low-side gauge should show pressure dropping a short time after the pump is placed into operation. A reading of approximately 28 to 29 inches of vacuum should be achieved in a short period of time.

If vacuum only reaches 10 or 15 inches of vacuum, there is still a leak somewhere in the system. Stop the vacuum pump. If there is a leak, the pump will draw moisture-laden air into the system. (Refer to "Leak Testing" elsewhere on this page).

If the vacuum specified is reached, let the pump continue to operate for as long as possible, the longer the better. One hour is adequate in most cases unless a system has been open for a long period of time.

NOTE: Make sure both high and low-side valves on manifold are closed prior to removing charging line from vacuum pump and proceeding to charge the system.

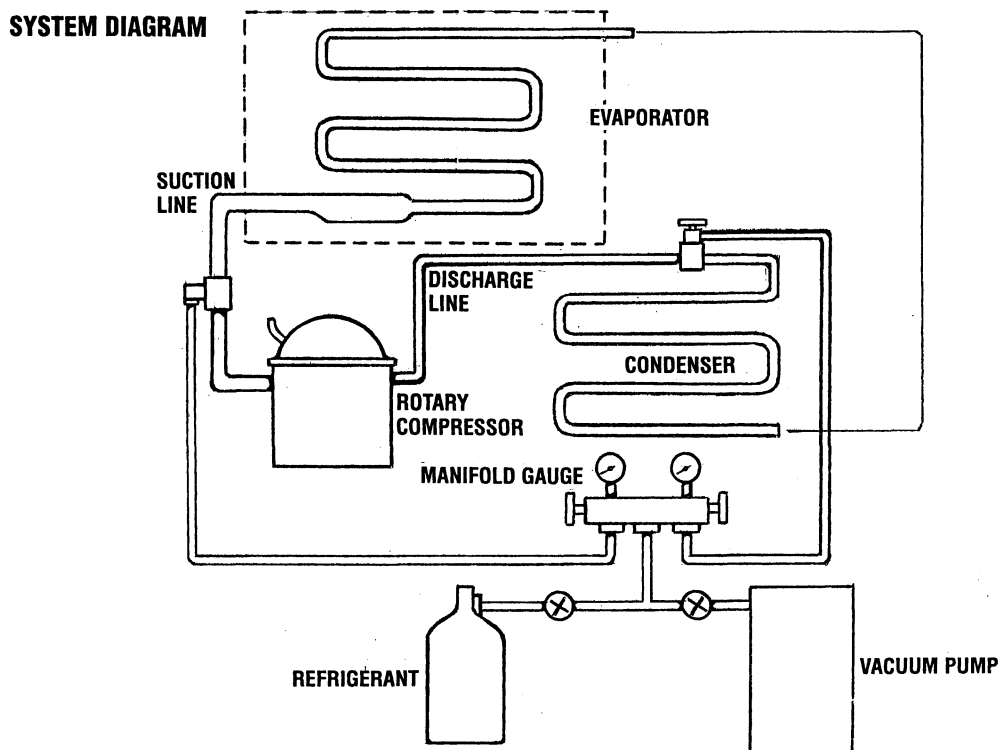

CHARGING THE SYSTEM

Charging (no refrigerant in system)

1. Disconnect the center hose of manifold gauge from the vacuum pump and connect it to the refrigerant cylinder.
2. With both gauge valves closed, open refrigerant cylinder valve and purge air from center line by unscrewing center hose from manifold until the air is purged.
3. With unit **OFF**, open the low-side valve fully and allow pressures on both low and high-side gauges to equalize.
4. Start the unit. Operate in the **cool** mode.
5. Continue to *slowly* charge through the low-side in vapor state until the *suction line starts to sweat and/or frost back*. Sweat on the suction line indicates a correct charge when the unit is in the **cool** mode. At this time, close the suction gauge valve and observe the operation of the unit. Take note of discharge air temperature as additional charging may be needed.

NOTE: *When in the **heat** mode after 15 minutes of running, the condenser coil (the coil in which **water in** and **water out** are connected) should start to sweat. If ice forms on this coil after 20 minutes of running, add refrigerant slowly until the ice dissipates and all you see is sweat.*

6. Another method is to completely recharge a system with a cylinder containing exactly the right amount of refrigerant according to the manufacturer's recommendations.
7. Running amperages should be checked and are as follows:
 - a) **Units with R22 refrigerant.**
10,000 BTU Cool - 8 Amps Heat -10 Amps
17,000 BTU Cool - 10 Amps Heat 12 Amps
 - b) **R22 refrigerant charge.**
10,000 BTU - 10.0 ounces
17,000 BTU - 13.0 ounces (1" diameter accumulator)
17,000 BTU - 14.5 ounces (2" diameter accumulator)
 - c) **Units with R22 refrigerant.**
10,000 BTU Cool - 8.0 Amps Heat -10.0 Amps
17,000 BTU Cool - 7.0 Amps Heat 10.0 Amps
 - d) **407C refrigerant charge.**
10,000 BTU - 7.5 ounces
17,000 BTU - 12.25 ounces (2" diameter accumulator)

The following points are important and bear repeating:

1. Always charge a system into the low-side. (BLUE)
2. Refrigerant should be put into the system in vapor form. Forcing liquid into the system may damage the compressor and injure the service technician.
3. Always remember that if a system is low on refrigerant there may be a leak. Locate and correct the leak(s) before the system is charged.

Leak Testing

Leaks may occur at soldered joints or at valve connections due to various causes such as vibration, misuse, or improper maintenance.

To find leaks, one must have enough pressure (R-22 or Nitrogen — NEVER Oxygen — as Oxygen is full of moisture and may contaminate a system) in the system for the leak to be identified.

Electronic leak detectors can detect a very small leak in hard-to-reach areas, but the unit must have refrigerant in it to be effective.

A soap bubble solution is an inexpensive and excellent method to detect leaks that can be used with both Nitrogen and refrigerant. With the unit pressurized to about 150 psi, spray the soap bubble solution on all soldered joints and valve connections and monitor the connections for bubbles which indicate a leak. Patience is a big factor and a very small leak can be overlooked easily.

COMPRESSOR CHECKS

ROTARY COMPRESSOR ELECTRICAL TEST

NOTE: The following electrical tests must be performed before condemning any compressor:

- a. Grounded compressor test.
- b. Open winding/open overload.
- c. Capacitor test.

If the above tests are completed and prove there is no apparent problem, refer to the section on the capacitor test.

COMPRESSOR GROUND TEST

To test a compressor for a grounded condition:

- a. Shut down power to the unit.
- b. Disconnect, identify, and clean leads from the compressor.
- c. With the ohmmeter set on (R x 1) scale, test for continuity between each compressor motor terminal and ground. If a reading is evident, the compressor is grounded and must be replaced.

OPEN WINDING TEST (SEE DIAGRAM BELOW)

- a). Shut **OFF** the unit's AC circuit breaker.
- b) Identify then disconnect the electrical connects to **R**, **C**, and **S**.
- c) Connect the Ohm meter leads across **C** and **S**. An Ohm value should be found.
- d) Connect the Ohm meter leads across **C** and **R**. An Ohm value should be found.
- e). Connect the Ohm meter leads across **S** and **R**. An Ohm value should be found.
- f) Place one of the Ohm meter leads to the metal of the compression case. With the other lead, momentarily touch **R** and **S** and the **C**. No Ohm should be found.

Should the compressor fail any of these tests (c, d, e, or f). it is faulty and must be replaced.

TESTING THE OVERLOAD PROTECTOR

With the power off, remove one side of the protector from its circuit.

Check it with an ohmmeter.

Full meter deflection (near zero resistance) means it is good. No meter deflection (high resistance) indicates an open protector and replacement is necessary.

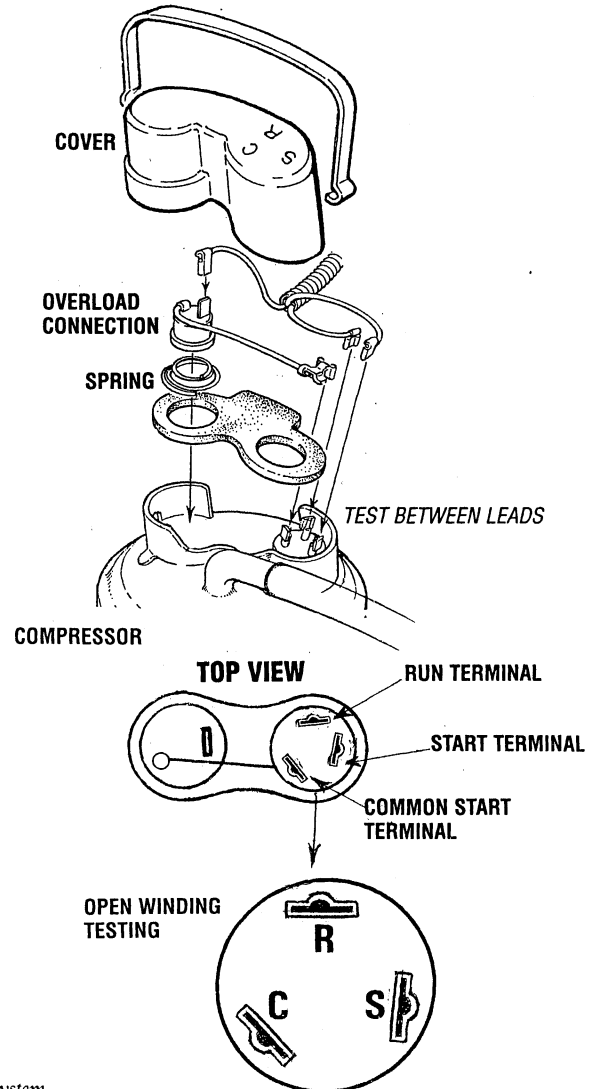

CAPACITOR CHECKS

⚠ WARNING: *Internally shorted capacitors can burst if energized directly. Never apply voltage to the capacitor before testing for a grounded, open or shorted condition. Always discharge the capacitor before conducting any of the following tests.*

CAPACITOR INSTALLATION INSTRUCTIONS

1. Turn off electrical power to the unit.
2. Discharge the capacitor.
3. Identify and remove the capacitor leads.
4. Perform a continuity check between each terminal of the capacitor and the bare metal of the capacitor. Any sign of resistance shows that the capacitor is grounded and must be replaced.
5. With the ohmmeter set to (R x 1), place the leads across the terminals and observe the action of the meter. The indicator should move from the high end of the scale to the low end and slowly return. If it deflects to the low end and does not return, the capacitor is shorted and must be replaced. If there is no deflection whatsoever, the capacitor is open and must be replaced.

NOTE: *Each capacitor has a microfarad and voltage rating dictated by the needs of the compressor motor. Sking, then, is an engineering function and service technicians should not deviate more than +10 mfd from factory capacitance specifications.*

HIGH PRESSURE SWITCH

1. To check the high pressure switch of the unit, shut off electrical circuits of the unit.
2. With the ohmmeter set to (R x 1) scale, place one lead on the overload protector wire and the other lead on the purple wire in the remote electrical box.
3. The ohmmeter needle should travel full scale. If not, check the high pressure switch for continuity. If open, the switch must be replaced.

MAINTENANCE

Periodic maintenance is required to ensure trouble free operation.

1. Clean and inspect the water strainer.
2. Clean and inspect the return air filters.
3. Check condensate for obstruction by pouring two (2) quarts of water over evaporators while making sure drainage occurs.
4. Visually inspect evaporators for restriction, blow cleaners needed.
5. Ensure proper tightening of all electric connections and hose clamps.

WINTERIZING

Remove the top hose of the unit which is the condenser's inlet water hose. This hose originates at the water pump. Allow the water to drain out through the discharge side of the condenser. If an air hose is available, low pressure air can be put through the condenser from the inlet side of the condenser.

Close the thru-hull seacock strainer, if applicable. Allow water to drain from the pump hose again. If available, low pressure air can be used to facilitate this process.

SPECIFICATIONS & GLOSSARY

Capillary Tube — A metering device used to reduce high pressure liquid refrigerant to low pressure liquid refrigerant.

Compressor — The compressor is a pump which draws cool, low pressure refrigerant gas and compresses the gas to a hot, high pressure gas.

Overload Protector (KLIXON) — Device used to protect the compressor from excessive heat in the motor.

Condenser — Receives hot, high pressure refrigerant gas from the compressor and cools this gaseous refrigerant until it returns to a liquid state.

Evaporator — The part of the system where the refrigerant vaporizes and absorbs heat. This is where the basic work is done in heating and cooling.

Hard Start Kit — A solid state Positive Temperature Coefficient Thermo-Resistor (PTCR). This serves the purpose of a start capacitor and relay, although the hard start kit is more efficient under low voltage conditions.

High Pressure Switch — Electrical control switch installed in the high pressure refrigerant line which automatically shuts down the compressor if too high a pressure is reached. The high pressure switch will protect the compressor if there was an overcharge condition or a water restriction.

Reversing Valve — Device used to reverse the direction of the refrigerant flow depending on whether heating or cooling is desired.

Reversing Valve Solenoid — An electrical part used to energize the reversing valve.

Run Capacitor — Used in some electrical motors, the run capacitor reduces the amperage and causes the motor to run more efficiently.

Strainer Refrigerant — Strainers are used to catch any particles that may be in the system and prevent them from entering the compressor.

Suction Line Accumulator — Serves the purpose of a drier and silica gel. It also protects the compressor from slugging liquid refrigerant back to the compressor and stores liquid refrigerant in the heat cycle.

Thermostat — A device which senses the ambient temperature conditions and in turn acts to control a circuit, cycling the compressor on or off.

Suction Line — Refrigerant line entering the bottom of the rotary compressor. The terms "suction line" and "suction side" may also be referred to as "low side" of the compressor.

Discharge Line — Refrigerant line exiting the top of the rotary compressor. The terms "discharge line" and "discharge side" may also be referred to as "high side" of the compressor.

ROTARY AIRE SPECIFICATIONS

	Rotary Aire 10.000 BTU	Rotary Aire 17.000 BTU
Size	20 1/2" X 13 3/4 X 13 1/4" (52 cm X 35 cm, X 33.7 cm)	21 1/4" X 16 1/2" X 13 1/2" (58.8 cm X 42 cm X 34.3 cm)
Cubic Feet	2.16	2.74
Cubic Meters	.061	.078
Weight	55 pounds (24.95 kg)	63 pounds (28.58 kg)
Running Amps	8 Cooling Mode @ 120 VAC/60 Hz 220/240 Volt 50/60 Hz (Available/Consult Factory)	10 Cooling Mode @ 120 VAC/60 Hz 220/240 Volt 50/60 Hz (Available/Consult Factory)
Evaporator Coil	10 Heating Mode Full Flow"V"	12 Heating Mode Full Flow"V"
Housing Construction	ABS Plastic	ABS Plastic
Compressor	Rotary, 3 moving parts	Rotary, 3 moving parts
Condensing Coil	Copper Nickel	Copper Nickel
Sea Water Flow	300 GPH (1135.6 LPH) minimum	500 GPH (1892.6 LPH) minimum
Warranty	(2) Two Years	(2) Two Years
Return Air Grill Size	144 sq. in. (925 sq. meters) minimum	164 sq. in. (1054 sq. meters) minimum
Discharge Grill(s) Size	50 sq. in. (323 sq. meters) minimum	70 sq. in. (448 sq. meters) minimum
Breaker Required	30 AMP - 120 VAC/15 AMP - 240 VAC	30 AMP - 120 VAC/15 AMP - 240 VAC
Discharge Opening	5 inch O.D.	6 inch O.D.

120 VOLT 60Hz WIRING DIAGRAM

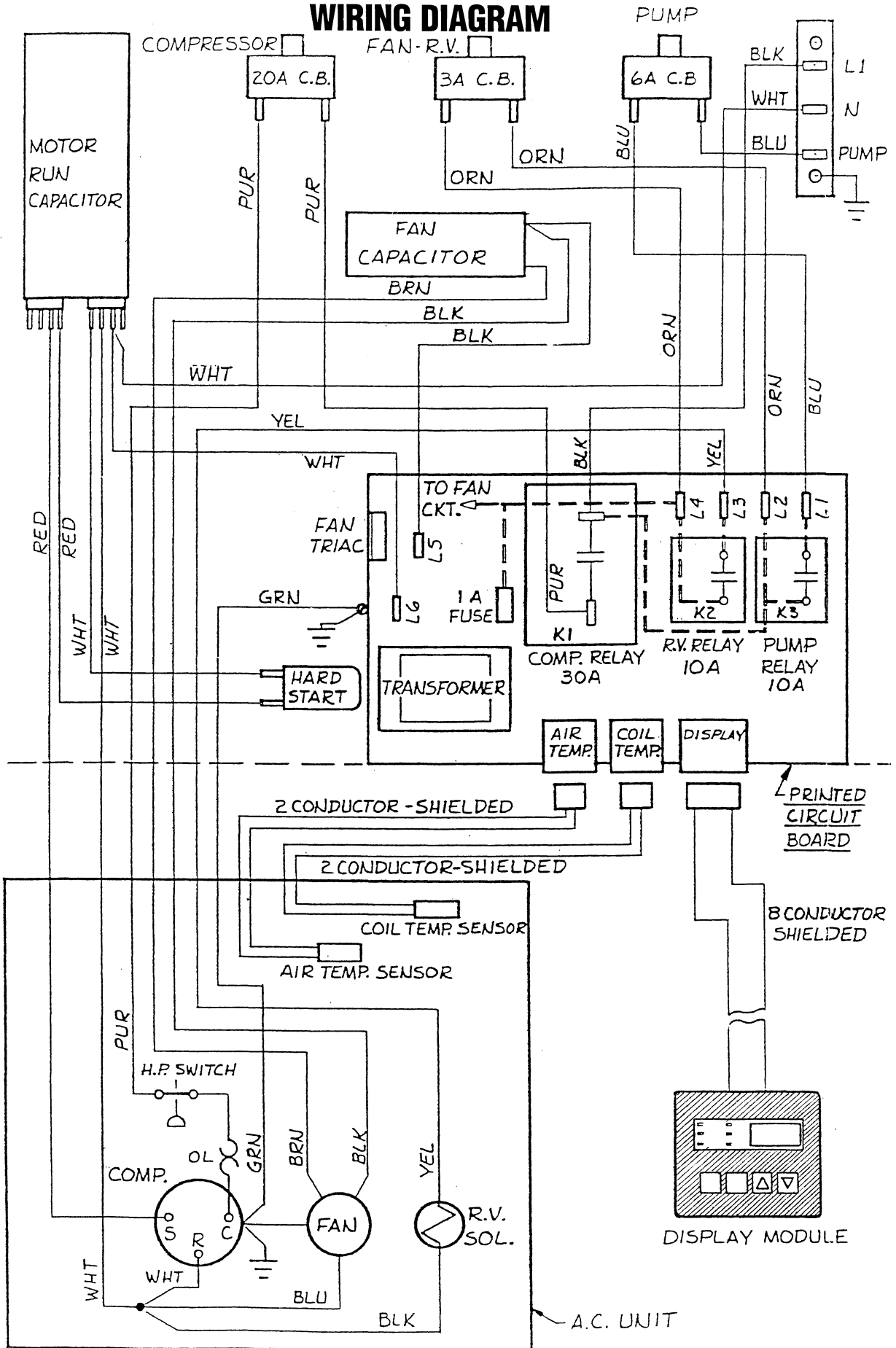

WIRING SCHEMATIC

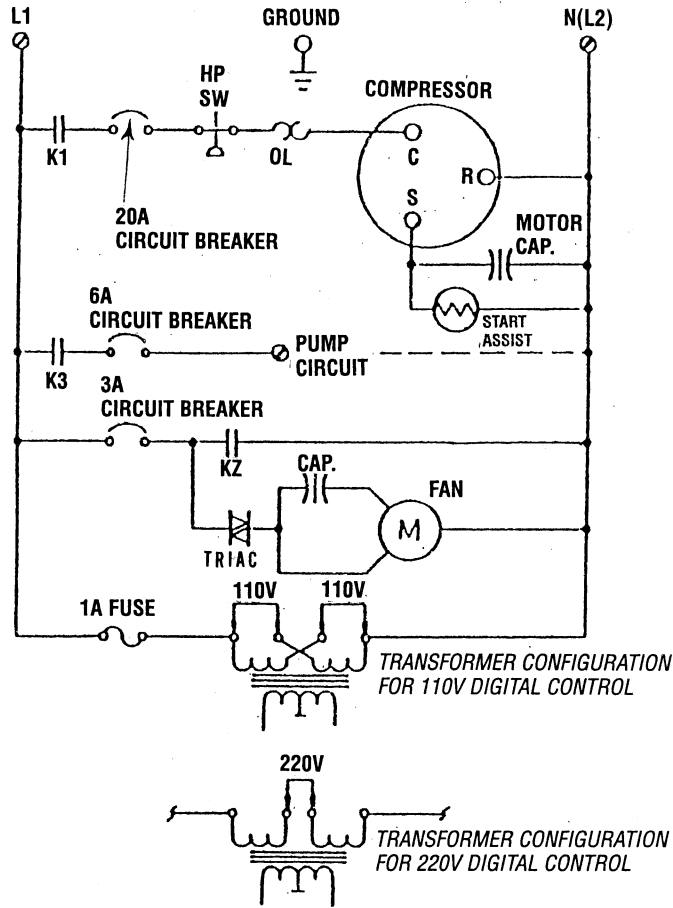

MAIN ELECTRICAL PANEL

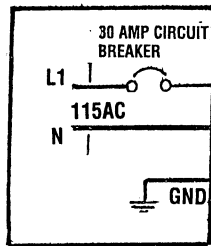

ALTERNATE GROUND STUD

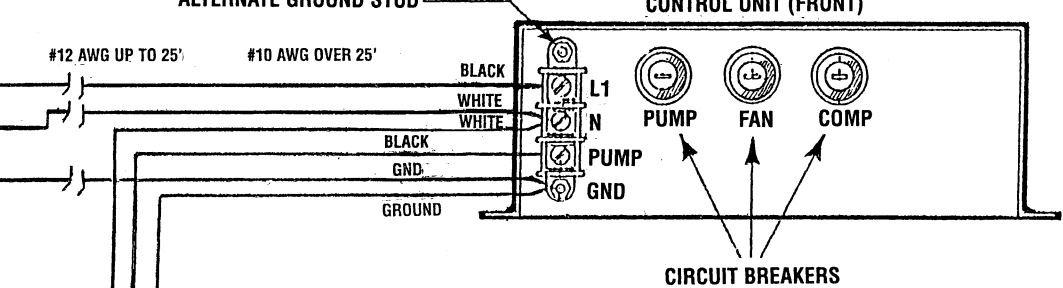

#14 AWG

WATER PUMP (115AC)

CONTROL UNIT (REAR)

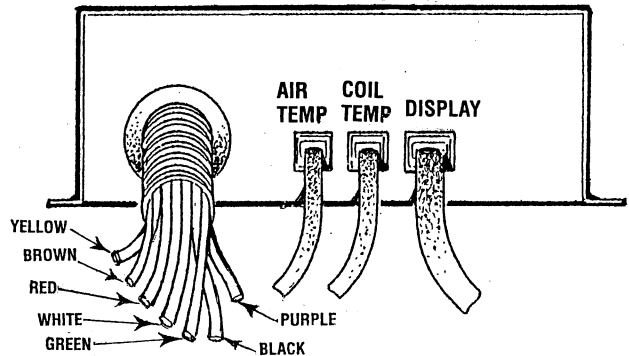

ROTARY AIRE MAIN ASSEMBLY

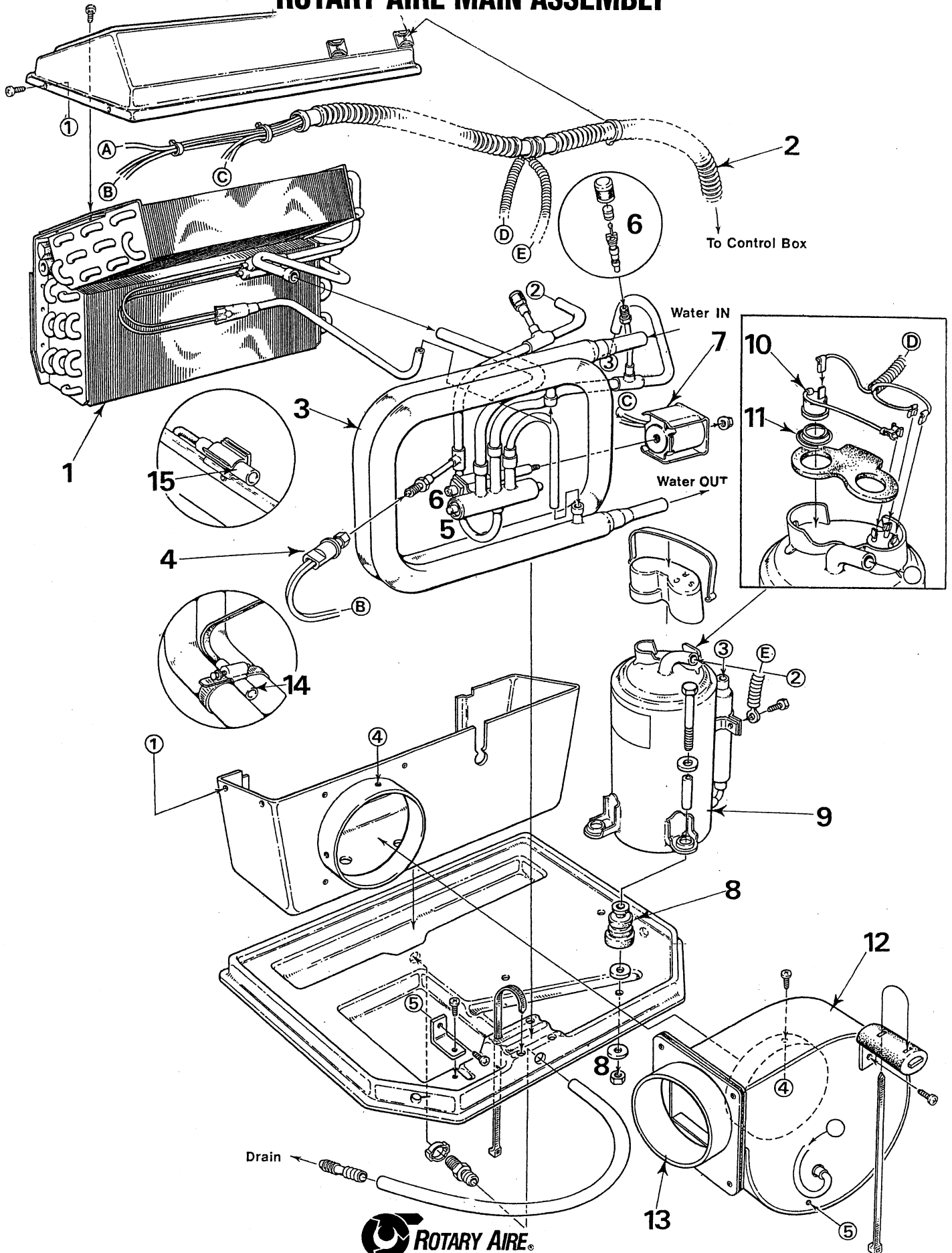

ROTARY AIRE MAIN ASSEMBLY

Key #	Part Number	Name	Description	Quantity
1	050535	Evaporator	Assembly 10,000 BTU	1
	050536	Evaporator	Assembly 17,000 BTU	1
2	050405	Harness	Standard Control Unit	1
	050408	Harness	MTC-IV Digital Control	1
	050539	Harness	Digital Control	1
3	050537	Condenser	Assembly 10,000 BTU	1
	050538	Condenser	Assembly 17,000 BTU	1
4	050140	Switch	High Pressure	1
5	050167	Valve	Reversing Included in Ref 3	1
6	050163	Valve	Schrader With Cap Included in Ref 3	3
7	050168	Solenoid	Reversing Valve 110 VAC	1
	050246	Solenoid	Reversing Valve 220 VAC	1
8	050529	Kit	Compressor Mounting Hardware	1
9	050150	Compressor	10,000 BTU 110 VAC	1
	050443	Compressor	10,000 BTU 220 VAC 50 Hz	1
	050151	Compressor	10,000 BTU 230 VAC 60 Hz	1
	050155	Compressor	17,000 BTU 110 VAC	1
	050445	Compressor	17,000 BTU 220 VAC 50 Hz	1
	050156	Compressor	17,000 BTU 220 VAC 60 Hz	1
10	050273	Overload	Thermal 10,000 BTU 110 VAC	1
	050274	Overload	Thermal 17,000 BTU 110 VAC	1
	050451	Overload	Thermal 10,000 BTU 220 VAC 50 Hz	1
	050453	Overload	Thermal 17,000 BTU 220 VAC 50 Hz	1
	050283	Overload	Thermal 10,000 BTU 220 VAC 60 Hz	1
	050284	Overload	Thermal 17,000 BTU 220 VAC 60 Hz	1
11	050275	Spring	Thermal Overload	1
12	050549	Fan	110 VAC 60 Hz (17,000 BTU)	1
	050546	Fan	110 VAC 60 Hz (10,000 BTU)	1
	050550	Fan	220 VAC 50 Hz/60 Hz (17,000 BTU)	1
	050548	Fan	220 VAC 50 Hz (10,000 BTU)	1
13	050159	Flange	5" Blower 10,000 BTU	1
	050160	Flange	6" Blower 17,000 BTU	1
14	050540	Sensor	Coil Temperature	1
15	050540	Sensor	Return Air Temperature	1

NOTE: When ordering parts, specify the part number, name and description.

MARINE CLIMATE CONTROL ELECTRICAL BOX

Key #	Part Number	Name	Description	Quantity
1	050509	Box	Digital Control Assy. 100 VAC Excl Ref 12	1
2	050188	Capacitor	30 MFD	1
3	050490	Clamp	Capacitor	1
4	050502	Hard Start		1
5	050400	Capacitor	Fan 10 MFD 110 VAC	1
	050428	Capacitor	Fan 3 MFD 220 VAC 60 Hz	1
	050456	Capacitor	Fan 4 MFD 10,000 BTU 220 VAC 50 Hz	1
	050428	Capacitor	Fan 3 MFD 17,000 BTU 220 VAC 50 Hz	1
6	050505	Breaker	Circuit 20 AMP 110 VAC	1
	050543	Breaker	Circuit 12 AMP 220 VAC	1
7	050503	Breaker	Circuit 3 AMP	1
8	050504	Breaker	Circuit 6 AMP 110 VAC	1
	050503	Breaker	Circuit 3 AMP 220 VAC	1
9	050506	Block	Terminal	1
10	050625	Board Assy.	Control 110 VAC	1
	050626	Board Assy.	Control 220 VAC	1
11	050440	Cable	Display 14 ft.	1
	050589	Coupler	Display Cable	1
12	050510	Display	Digital Control	1
13	050589	Coupler	Cable Coupler	1

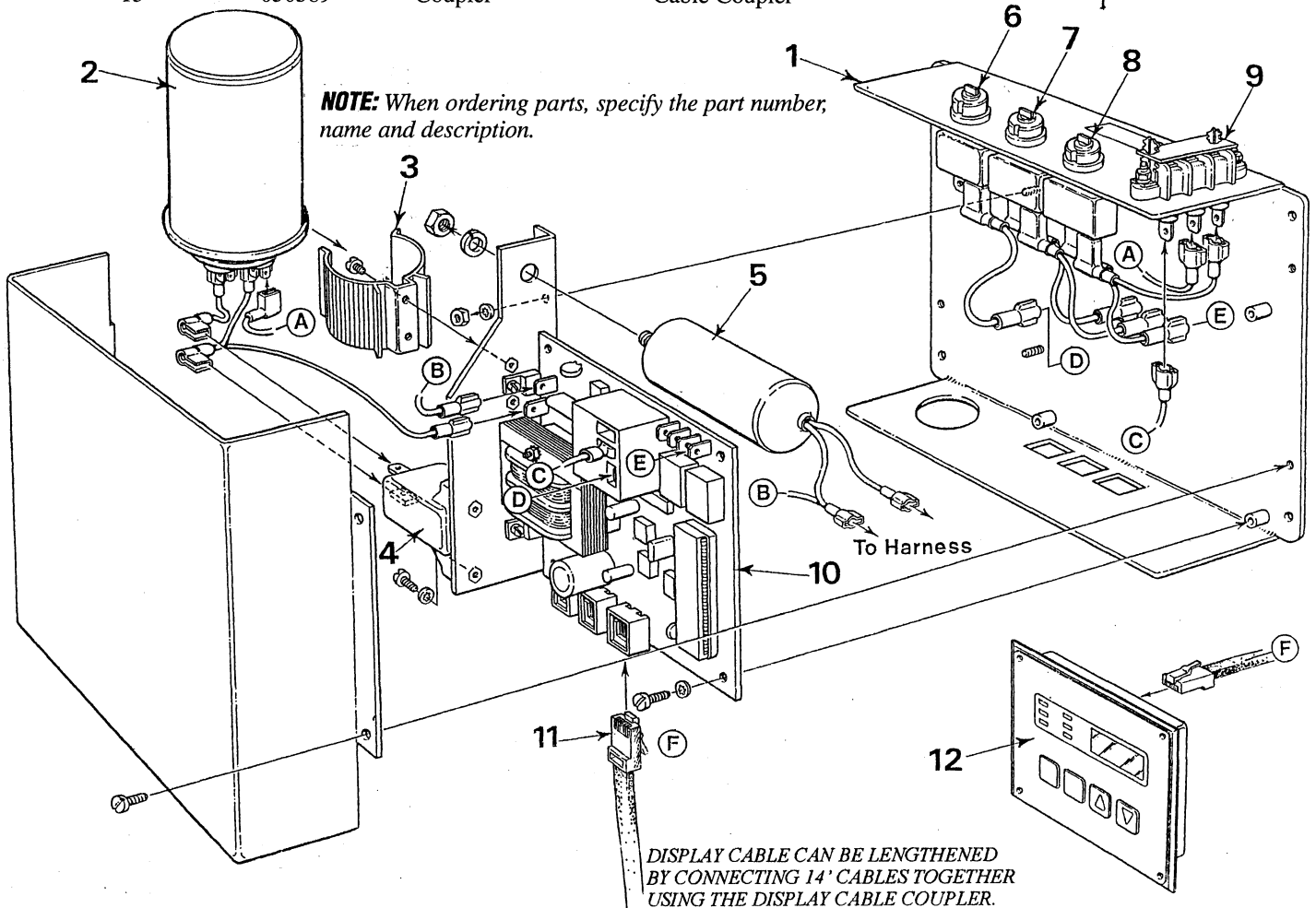

ACCESSORIES PARTS LIST

SUPPLY GRILLS

Part Number	Description
050026	4" Round Black
050029	4" Round Tan
050031	4"x4" Teak
050032	4"x8" Teak
050033	4"x10" Teak
050034	4"x12" Teak
050038	5"x10" Teak
050039	5"x12" Teak
050041	6"x12" Teak
050079	4"x10" Aluminum
050080	4"x12" Aluminum
050082	8"x4" Aluminum
050084	10"x5" Aluminum
050085	12"x5" Aluminum

RETURN GRILLS

Part Number	Description
050092	14"x7" Teak
050093	14"x10" Teak
050094	14"x12" Teak
050095	16"x9" Teak
050096	14"x7" Aluminum
050097	14"x10" Aluminum
050098	14"x12" Aluminum
050099	16"x9" Aluminum

TRANSITION BOXES

Part Number	Description
050064	4"x4" Plastic Vacuform
050065	4"x8" Plastic Vacuform
050066	4"x10" Plastic Vacuform
050067	4"x12" Plastic Vacuform
050070	5"x10" Plastic Vacuform
050071	5"x12" Plastic Vacuform
050073	6"x12" Plastic Vacuform

DUCTING

Part Number	Description
050101	3" Ducting Per Foot
050102	4" Ducting Per Foot
050103	5" Ducting Per Foot
050104	6" Ducting Per Foot
050574	4" Ducting Insulation (25' per box)
050105	5" Ducting Insulation (25' per box)
050106	6" Ducting Insulation (25' per box)
050110	4" Ducting Ring, Round
050111	5" Ducting Ring, Round
050113	4" Ducting Ring, Oval
050114	5" Ducting Ring, Oval
050115	6" Ducting Ring, Oval
050112	6" Ducting Ring, Round
050116	5"x4"x4" T Duct
050117	5"x5"x4" Y Duct
050118	6"x5"x5" T Duct
050119	6"x6"x4" Y Duct
050120	5"x4" Duct Reducer
050121	4"x3" Duct Reducer

WATER PUMPS

Part Number	Description
050021	Pump, 500 GPH, 115VAC, 60Hz
050022	Pump, 1000 GPH, 115VAC, 60Hz
050294	Pump, 500 GPH, 230VAC, 60Hz
050363	Pump, 1000 GPH, 230VAC, 60Hz
050449	Pump, 500 GPH, 220VAC, 50 Hz
050452	Pump, 1000 GPH, 220VAC, 50 Hz
050544	Pump, 900 GPH, 115VAC, 60Hz
050545	Pump, 1500 GPH, 115VAC, 60Hz
050562	Pump, 900 GPH, 230VAC, 60Hz
050563	Pump, 900 GPH, 220VAC, 50Hz
050023	Pump, 800/1000 GPH, 50/60Hz (All Bronze)
050015	Pump Relay-2 Units
050016	Pump Relay-3 to 6 Units

PUMP KITS

Part Number	Description
050025	Fitting Kit, 500 GPH Pump
050269	Fitting Kit, 1000 GPH Pump
050394	Repair Kit, 500 GPH Pump
050395	Repair Kit, 1000 GPH Pump

ADDITIONAL ACCESSORIES

Part Number	Description
050454	Padding 10,000 BTU Unit
050455	Padding 17,000 BTU Unit
050122	Padding Material (per square foot).
050387	Filter Set, 2 each 4"x13 1/2" Filters
050388	Filter Set, 2 each 4"x15" Filters
050125	.75" Intake Scoop
050124	1" Intake Scoop
050321	1.25" Intake Scoop
050127	.75" Water Strainer
050126	1" Water Strainer
050270	Fitting Kit, Strainer, PVC
050440	Cable, 14' Digital Thermostat
050589	Connector, Digital Wiring Harness
050128	.625" Water Hose (per linear foot)
050134	.75" Water Hose (per linear foot)
050133	.625" Water Hose (per linear foot)
050129	10/3 Wire (per linear foot)
050130	12/3 Wire (per linear foot)
050131	14/3 Wire (per linear foot)
050137	Relay, 110 VAC

NOTE: Contact your ROTARY AIRE DEALER for additional information and prices.

When ordering parts, specify the part number, name and description.

STANDARD AND METRIC CONVERSION DATA

LENGTH-DISTANCE

Inches (in) x 25.4 = Millimeters (mm) x .0394 = Inches
Feet (ft) x .305 = Meters (m) x 3.281 = Feet
Miles x 1.609 = Kilometers (km) x .0621 = Miles

DISTANCE EQUIVALENTS

1 Degree of Latitude = 60 Nm = 111.120 km
1 Minute of Latitude = 1 Nm = 1.852 km

VOLUME

Cubic Inches (in³) x 16.387 = Cubic Centimeters x .061 = in³
Imperial Pints (IMP pt) x .568 = Liters (L) x 1.76 = IMP pt
Imperial Quarts (IMP qt) x 1.137 = Liters (L) x .88 = IMP qt
Imperial Gallons (IMP gal) x 4.546 = Liters (L) x .22 = IMP gal
Imperial Quarts (IMP qt) x 1.201 = US Quarts (US qt) x .833 = IMP qt
Imperial Gallons (IMP gal) x 1.201 = US Gallons (US gal) x .833 = IMP gal
Fluid Ounces x 29.573 = Milliliters x .034 = Ounces
US Pints (US pt) x .473 = Liters(L) x 2.113 = Pints
US Quarts (US qt) x .946 = Liters (L) x 1.057 = Quarts
US Gallons (US gal) x 3.785 = Liters (L) x .264 = Gallons

MASS-WEIGHT

Ounces (oz) x 28.35 = Grams (g) x .035 = Ounces
Pounds (lb) x .454 = Kilograms (kg) x 2.205 = Pounds

PRESSURE

Pounds Per Sq In (psi) x 6.895 = Kilopascals (kPa) x .145 = psi
Inches of Mercury (Hg) x .4912 = psi x 2.036 = Hg
Inches of Mercury (Hg) x 3.377 = Kilopascals (kPa) x .2961 = Hg
Inches of Water (H₂O) x .07355 = Inches of Mercury x 13.783 = H₂O
Inches of Water (H₂O) x .03613 = psi x 27.684 = H₂O
Inches of Water (H₂O) x .248 = Kilopascals (kPa) x 4.026 = H₂O

TORQUE

Pounds-Force Inches (in-lb) x .113 = Newton Meters (Nm) x 8.85 = in-lb
Pounds-Force Feet (ft-lb) x 1.356 = Newton Meters (Nm) x .738 = ft-lb

VELOCITY

Miles Per Hour (MPH) x 1.609 = Kilometers Per Hour (KPH) x .621 = MPH

POWER

Horsepower (Hp) x .745 = Kilowatts (Kw) x 1.34 = MPH

FUEL CONSUMPTION

Miles Per Hour IMP (MPG) x .354 = Kilometers Per Liter (Km/L)
Kilometers Per Liter (Km/L) x 2.352 = IMP MPG
Miles Per Gallons US (MPG) x .425 = Kilometers Per Liter (Km/L)
Kilometers Per Liter (Km/L) x 2.352 = US MPG

TEMPERATURE

Degree Fahrenheit (°F) = (°C X 1.8) + 32
Degree Celsius (°C) = (°F - 32) x .56

LIQUID WEIGHTS

Diesel Oil = 1 US gallon = 7.13 lbs
Fresh Water = 1 US gallon = 8.33 lbs
Gasoline = 1 US gallon = 6.1 lbs
Salt Water = 1 US gallon = 8.56 lbs

**WESTERBEKE CORPORATION
 ROTARY AIRE MARINE AIR CONDITIONER
 2-YEAR LIMITED WARRANTY**

WARRANTY

Westerbeke Corporation warrants that the following products (and their parts) will be free from defects in material, design, and workmanship from their original date of purchase through the following coverage periods, subject to the general limitations and exclusions set forth below:

A. PRODUCTS COVERED

Westerbeke Rotary Aire 10,000 and 17,000 BTU air conditioners.

B. PERIODS AND EXTENT OF COVERAGE

1. Products purchased by a consumer and at all times used in pleasure craft for personal and family use are covered for two (2) years from the original date of purchase. All parts (other than those parts excluded below); and labor, travel, transportation, removal and reinstallation expenses (each as limited below), are covered during such period.
2. Products used at any time in commercial, charter, rental, leasing, or other such applications are warranted for a period of one (1). All parts (other than those parts excluded below); and labor, travel, transportation, removal and reinstallation expenses (each as limited below) are covered during such period.

C. GENERAL LIMITATIONS AND EXCLUSIONS FROM COVERAGE

1. Expenses Covered and Their Limitations
 - a. Labor expense coverage is limited to the labor time allotted for the applicable service from the most recent Westerbeke Rotary Aire flat rate time schedule in effect at Westerbeke Rotary Aire most recently approved regional hourly labor rate in effect. The applicable flat rate time schedule and approved regional hourly labor rate are available at each Westerbeke Master Distributor and may be amended by Westerbeke from time to time without notice.

- b. Travel mileage expense coverage is limited to a total of 300 miles at the Westerbeke approved mileage rate in effect. Labor time coverage relating to travel is limited to a total of six (6) hours.
- c. Transportation expense coverage is limited to standard methods of transportation such as truck, sea, rail, UPS, and parcel post. Premium transportation charges, such as air freight, are not covered.
- d. Difficult access to the product or preparation tasks, such as moving furniture and carpets, all of which are expressly excluded from coverage.

2. Other Exclusions from Coverage

Coverage under this warranty shall not apply to, among other things:

- a. Product failures or damage caused by the user's failure to follow the installation, operation and other instructions found in the written material provided with the product, including, for example and without limitation, failures or damage caused by (i) inadequate or improper installation, start-up operation, use, maintenance, adjustments or storage; (ii) defects in the system or application in which the product is installed or used; (iii) water intrusion of any kind; (iv) the use of non-Westerbeke Rotary Aire factory supplied or approved parts; or (v) the failure to heed safety warnings.
- b. Failures or damage caused by accessories attached to the product.
- c. Damage occurring in transit after the product leaves Westerbeke Rotary Aire's factory.
- d. Parts requiring replacement due to their normal wear and tear.

THIS WARRANTY IS IN LIEU OF ALL OTHER EXPRESS OR IMPLIED WARRANTIES, INCLUDING WITHOUT LIMITATION, WARRANTIES OF FITNESS AND MERCHANTABILITY, AND THERE ARE NO WARRANTIES WHICH EXTEND BEYOND THE DESCRIPTION OF THE FACE HEREOF. ANY WARRANTY IMPLIED BY LAW, IS IN EFFECT ONLY FOR THE DURATION OF THE EXPRESS WARRANTY SET FORTH HEREIN. NO REPRESENTATIVE OR PERSON IS AUTHORIZED TO GIVE ANY OTHER WARRANTY OR TO ASSUME FOR WESTERBEKE CORPORATION ANY OTHER LIABILITY IN CONNECTION WITH THE SALE OR SERVICE OF ITS PRODUCTS. WESTERBEKE CORPORATION WILL NOT BE LIABLE FOR ANY CONSEQUENTIAL OR INCIDENTAL DAMAGES (INCLUDING WITHOUT LIMITATION THOSE SPECIFIED HEREIN) RESULTING FROM THE INSTALLATION, OPERATION OR USE OF ITS PRODUCTS. SOME STATES DO NOT ALLOW LIMITATIONS ON HOW LONG AN IMPLIED WARRANTY LASTS OR THE EXCLUSIONS OR LIMITATIONS OF INCIDENTAL OR CONSEQUENTIAL DAMAGES, SO THE ABOVE LIMITATIONS AND EXCLUSIONS MAY NOT APPLY TO YOU. THIS WARRANTY GIVES YOU SPECIFIC LEGAL RIGHTS, AND YOU MAY ALSO HAVE OTHER RIGHTS WHICH VARY FROM STATE TO STATE.

<hr style="border: 0; border-top: 1px solid black; margin-bottom: 5px;"/> Model
<hr style="border: 0; border-top: 1px solid black; margin-bottom: 5px;"/> Serial Number Effective: July 1, 2009 Edition: D P/N: 39474

- e. Parts and other items normally replaced during routine maintenance, such as (to the extent applicable of the particular product) hose claims, gaskets, seals, and refrigerant.
- f. Products which have been altered or modified from their standard configuration in a manner not authorized by Westerbeke Rotary Aire in writing.
- g. Parts installed or repaired by someone other than an authorized service person.
- h. Products specially manufactured or configured to meet customer specifications.
- i. Expenses relating to (i) communication, such as telephone, telegraph, telex or telefax; (ii) living and travel, such as meals, lodging and tolls; (iii) rental of equipment or any other item; (iv) use of consumable parts and consumable fluids such as lubrication oil, coolant, lubricants, paint and similar items; (v) towing charges, dockage, storage, crane fees, captain's fees, and other similar services; and (vi) inconvenience or loss of time or income.

3. Other Restrictions

- a. All claims must be brought to the attention of Westerbeke Rotary Aire or its authorized service representative within thirty (30) days after discovery that any product fails within the coverage afforded by this warranty.
- b. All warranty service must only be performed by a Westerbeke Rotary Aire authorized service representative to whom you have been referred by your nearest Westerbeke Rotary Aire Master Distributor. Please refer to the warranty service procedures section set forth below.
- c. Any parts replaced under this warranty are warranted only from the original date of purchase of the warranted product of which they are a part.

D. PRODUCT REGISTRATION

WESTERBEKE ROTARY AIRE REQUIRES AS A PREREQUISITE TO WARRANTY COVERAGE HEREUNDER THAT THE ORIGINAL OWNER COMPLETE AND RETURN TO WESTERBEKE THE REGISTRATION CARD PROVIDED WITH THE PRODUCT.

E. WARRANTY SERVICE PROCEDURES AND REMEDIES

1. Service Procedures

Locate your nearest Westerbeke Rotary Aire Master Distributor from the directory provided with your product, in your local telephone directory, or by contacting the Westerbeke Rotary Aire Warranty Department at the address set forth below.

2. Contact this Westerbeke Rotary Aire Master Distributor and request warranty service. Be prepared to furnish the following information:

- a. Owner's name, address, business and home telephone numbers;
- b. Model and serial number;
- c. Date of purchase;
- d. Boat model, the name of the boat, and the present location of the boat or product;
- e. Name and address of the boat manufacturer;
- f. Description of the current problem;
- g. The name of any service outlet previously contacted and their diagnosis; and
- h. Information regarding any prior problems, servicing or installation.

The Master Distributor will identify an appropriate Westerbeke Rotary Aire authorized service representative for you to contact.

4. Contact this Westerbeke Rotary Aire authorized service representative and make arrangements to have warranty service performed.

5. Repairs or replacements will be furnished if, following inspection by Westerbeke Rotary Aire or its authorized representative, such repairs or replacements are deemed by Westerbeke Rotary Aire to be appropriate and consistent with this warranty in the good faith exercise of Westerbeke Rotary Aire's best judgment (which judgment shall be binding).

F. FOR ANSWERS TO QUESTIONS

If for any reason you should encounter a problem or have any questions concerning warranty service, please contact:

Westerbeke Warranty Department
 Westerbeke Corporation
 150 John Hancock Road
 Myles Standish Industrial Park
 Taunton, MA 02780-7319
 Telephone: (508) 823-7677
 Website: www.westerbeke.com

G. MISCELLANEOUS

Westerbeke's Rotary Aire, Inc.'s sole liability and the owner's sole remedy for a failure of any product under this warranty and for any and all other claims arising to the purchase and use of any Westerbeke Rotary Aire product shall be limited to the repair and replacement of the product or its applicable parts by Westerbeke Rotary Aire, Inc. or by its authorized representative under the terms of this warranty. Any provision of this warranty which is prohibited or unenforceable in any jurisdiction shall, as to such jurisdiction, be ineffective to the extent of such prohibition or unenforceability without invalidating the remaining provisions hereof or affecting the validity or enforceability of such provision in any other jurisdiction.

