

# **PARTS LIST**

**WESTERBEKE 10TWO  
Marine Diesel Engine**

**WESTERBEKE 3KW  
Marine Diesel Generator**

**Publication no. 33404  
Edition One  
April 1984**



*WESTERBEKE CORPORATION  
MYLES STANDISH INDUSTRIAL PARK  
150 JOHN HANCOCK ROAD, TAUNTON, MA 02780-7319*

# **PARTS LIST**

**WESTERBEKE 10TWO  
Marine Diesel Engine**

**WESTERBEKE 3KW  
Marine Diesel Generator**

**Publication no. 33404  
Edition One  
April 1984**



IMPORTANT

PRODUCT SOFTWARE NOTICE

Product software of all kinds, such as brochures, drawings, technical data, operator's and workshop manuals, parts lists and parts price lists, and other information, instructions and specifications provided from sources other than Westerbeke, is not within Westerbeke's control and, accordingly, is provided to Westerbeke customers only as a courtesy and service. WESTERBEKE CANNOT BE RESPONSIBLE FOR THE CONTENT OF SUCH SOFTWARE, MAKES NO WARRANTIES OR REPRESENTATIONS WITH RESPECT THERETO, INCLUDING THE ACCURACY, TIMELINESS OR COMPLETENESS THEREOF, AND WILL IN NO EVENT BE LIABLE FOR ANY TYPE OF DAMAGES OR INJURY INCURRED IN CONNECTION WITH, OR ARISING OUT OF, THE FURNISHING OR USE OF SUCH SOFTWARE.

For example, components and sub-assemblies incorporated in Westerbeke's products and supplied by others (such as engine blocks, fuel systems and components, transmissions, electrical components, pumps and other products) are generally supported by their manufacturers with their own software, and Westerbeke must depend on such software for the design of Westerbeke's own product software. Such software may be outdated and no longer accurate. Routine changes made by Westerbeke's suppliers, of which Westerbeke rarely has notice in advance, are frequently not reflected in the supplier's software until after such changes take place.

Westerbeke customers should also keep in mind the time span between printings of Westerbeke product software, and the unavoidable existence of earlier, non-current Westerbeke software editions in the field. Additionally, most Westerbeke products include customer-requested special features that frequently do not include complete documentation.

In sum, product software provided with Westerbeke products, whether from Westerbeke or other suppliers, must not and cannot be relied upon exclusively as the definitive authority on the respective product. It not only makes good sense, but is imperative that appropriate representatives of Westerbeke or the supplier in question be consulted to determine the accuracy and currency of the product software being consulted by the customer.

## TABLE OF CONTENTS

200	WESTERBEKE 10TWO	CYLINDER BLOCK AND HEAD
202	WESTERBEKE 10TWO	CRANKSHAFT - PISTONS
204	WESTERBEKE 10TWO	CAMSHAFT - ROCKER SHAFT
206	WESTERBEKE 10TWO	LUBE OIL PUMP AND SUMP
208	WESTERBEKE 10TWO	COOLING SYSTEM
212	WESTERBEKE 10TWO	SEA WATER PUMP
214	WESTERBEKE 10TWO	FRESH WATER PUMP - ALTERNATOR
216	WESTERBEKE 10TWO	GOVERNOR
218	WESTERBEKE 10TWO	IDLE STOP ASSEMBLY
220	WESTERBEKE 10TWO	FUEL SYSTEM
226	WESTERBEKE 10TWO	PROPULSION BACK END AND MOUNTING SYSTEM
230	WESTERBEKE 10TWO	ELECTRICAL SYSTEM
232	WESTERBEKE 10TWO	MARINE HARNESS
234	WESTERBEKE 10TWO	PROPULSION INSTRUMENT PANEL
236	WESTERBEKE 3KW	GENERATOR MOUNTING SYSTEM
238	WESTERBEKE 3KW	ELECTRICAL SYSTEM
240	WESTERBEKE 3KW	GENERATOR HARNESS
242	WESTERBEKE 3KW	GENERATOR CONTROL PANEL
244	WESTERBEKE 3KW	FUEL SOLENOID ASSEMBLY
246	WESTERBEKE 3KW	GENERATOR 2 WIRE 60 HERTZ
250	WESTERBEKE 3KW	GENERATOR 3 WIRE 60 HERTZ
254	WESTERBEKE 3KW	BELT GUARD
256	WESTERBEKE 10TWO	MISCELLANEOUS

WESTERBEKE 10TWC - CYLINDER BLOCK AND HEAD

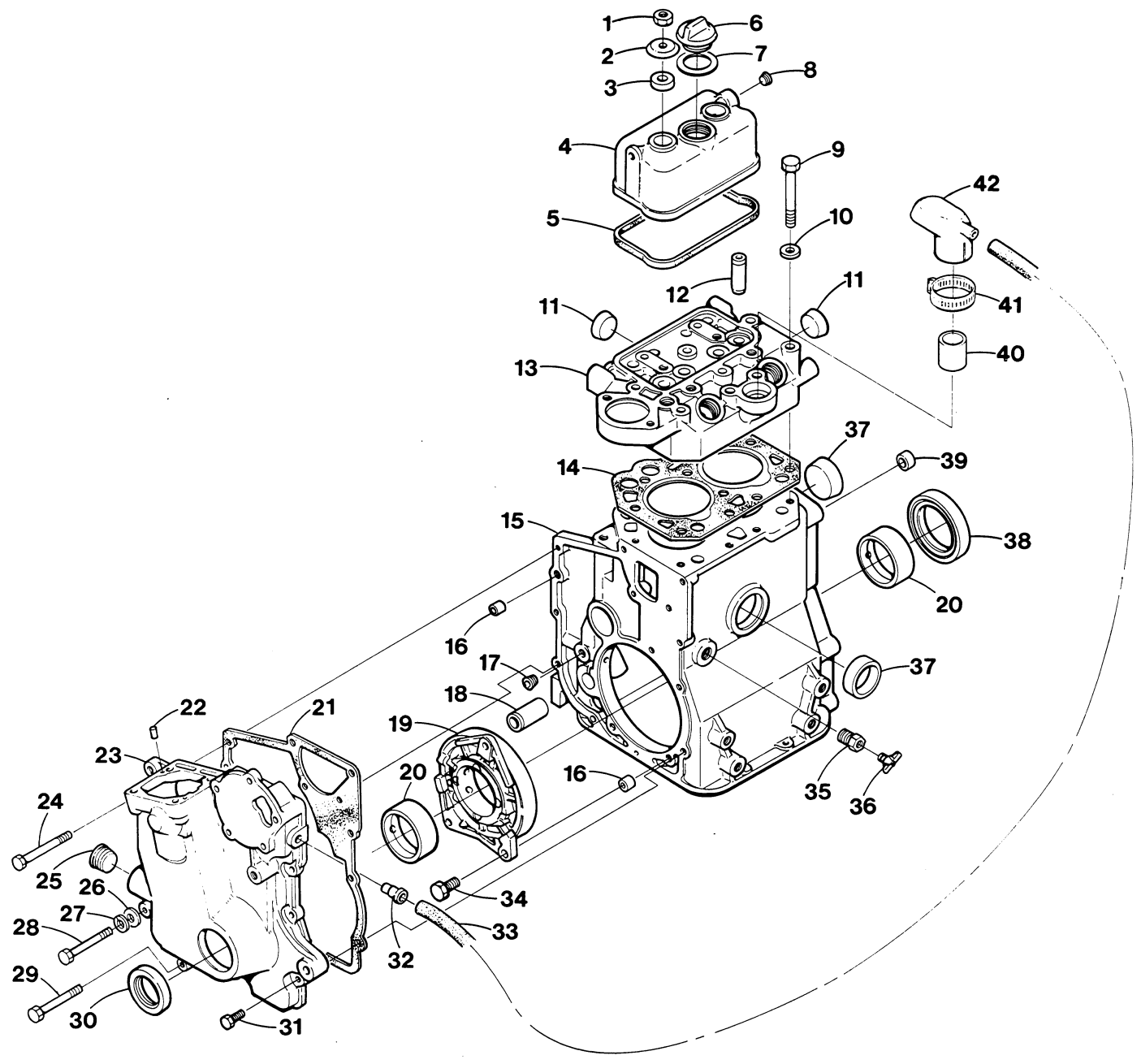

WESTERBEKE 10TWC - CYLINDER BLOCK AND HEAD

REF	PN	NAME	REMARKS	QUAN
1	18242	NUT	M8 DIN 934	2
2	30517	WASHER		2
3	30780	SEAL	OIL-ROCKER COVER STUD	2
4	33163	COVER	ROCKER	1
5	33164	GASKET	ROCKER COVER	1
6	33126	CAP	OIL FILLER WITH O-RING	1
7	33123	C-RING	OIL FILLER CAP	1
8	33127	PLUG		1
9	33135	BOLT	CYLINDER HEAD	10
10	33136	WASHER	CYLINDER HEAD BOLT	10
11	30714	PLUG	EXPANSION-25	2
12	33134	GUIDE	VALVE	4
13	33161	HEAD	CYLINDER WITH PLUGS AND VALVE GUIDES	1
14	33162	GASKET	HEAD	1
15- 1	32070	BLOCK	ASSEMBLY	1
15- 2	33160	BLOCK	BARE	1
16	33212	DOWEL	TUBULAR 6 X 9	2
17	30711	PLUG	1/8	2
18	33202	SHAFT	GOVERNOR GEAR	1
19	33132	HOUSING	BEARING	1
20- 1	33128	BEARING	CRANKSHAFT-STD	2
20- 2	33129	BEARING	CRANKSHAFT-0.25	2
20- 3	33130	BEARING	CRANKSHAFT-0.50	2
20- 4	33131	BEARING	CRANKSHAFT-0.75	2
21	33167	GASKET	TIMING CASE	1
22	30224	DOWEL		2
23	33166	CASE	TIMING	1
24	34212	CAPSCREW	M6 X 75 DIN 931	1
25	30713	PLUG		1
26	31784	WASHER	FLAT M6 DIN 125	1
27	31783	LOCKWASHER	M6 DIN 127	1
28	33351	CAPSCREW	M6 X 60 DIN 931	1
29	30146	CAPSCREW	M6 X 55 DIN 931	3
30	30209	SEAL	OIL	1
31	18804	CAPSCREW	M6 X 20 DIN 933	4
32	30219	NIPPLE	BREATHER HOSE	1
33	33165	HOSE	BREATHER	1
34	17196	CAPSCREW	M8 X 20 DIN 933	3
35	24752	BUSHING	1/4BSPT TO 1/8NPT	1
36	11471	PETCOCK		1
37	30716	FLUG	EXPANSION-40	2
38	33133	SEAL	OIL	1
39	30708	DOWEL	TUBULAR 10 X 9	2
40	33121	ADAPTER	HEAD TO AIR INTAKE SILENCER	1
41	21878	CLAMP		1
42	32434	SILENCER	AIR INTAKE	1

WESTERBEKE 10TWO - CRANKSHAFT - PISTONS

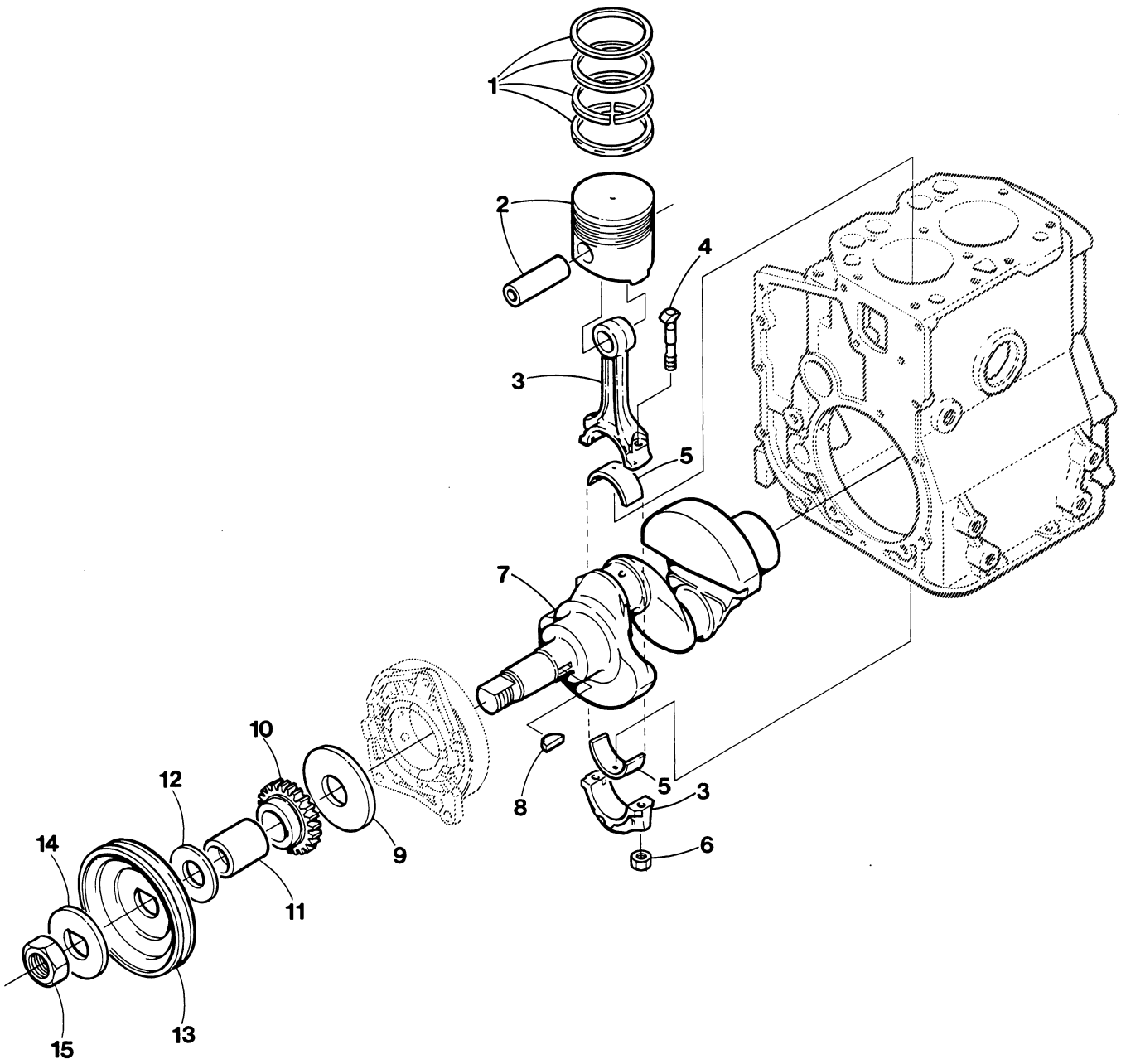

WESTERBEKE 10TWO - CRANKSHAFT - PISTONS

REF	PN	NAME	REMARKS	QUAN
1- 1	33175	RING SET	STD	2
1- 2	33176	RING SET	0.25	2
1- 3	33177	RING SET	0.50	2
1- 4	33178	RING SET	0.75	2
2- 1	33137	PISTON	WITH PIN-STD	2
2- 2	33138	PISTON	WITH PIN-0.25	2
2- 3	33139	PISTON	WITH PIN-0.50	2
2- 4	33140	PISTON	WITH PIN-0.75	2
3	33141	ROD	CONNECTING	2
4	30351	BOLT	CONNECTING ROD	4
5- 1	33142	BEARING	CONNECTING ROD SET-STD	2
5- 2	33143	BEARING	CONNECTING ROD SET-0.25	2
5- 3	33144	BEARING	CONNECTING ROD SET-0.50	2
5- 4	33145	BEARING	CONNECTING ROD SET-0.75	2
6	30231	NUT	CONNECTING ROD BOLT	4
7	33171	CRANKSHAFT		1
8	30275	KEY	WOODRUFF 5X9	1
9	33173	PLATE	CRANKSHAFT	1
10	33172	GEAR	CRANKSHAFT	1
11	33174	SPACER		1
12	30216	WASHER	FLAT M24	1
13	33158	PULLEY	CRANKSHAFT	1
14	30216	WASHER	FLAT M24	1
15	32174	NUT	CRANKSHAFT PULLEY	1



WESTERBEKE 10TWC - CAMSHAFT - ROCKER SHAFT

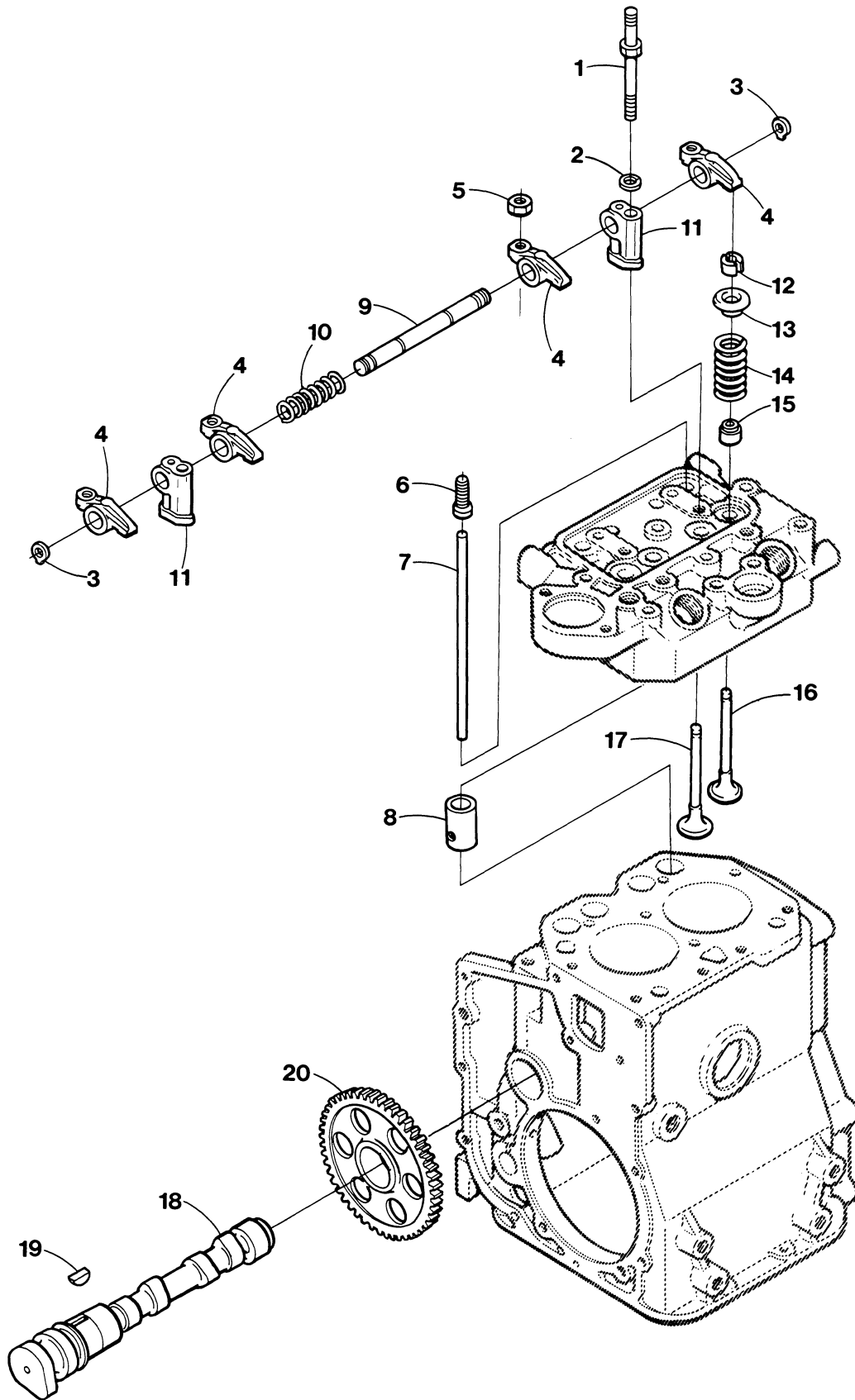

WESTERBEKE 10TWO - CAMSHAFT - ROCKER SHAFT

REF	PN	NAME	REMARKS	QUAN
1	33180	STUD	ROCKER SHAFT BRACKET	2
2	31787	WASHER	FLAT-M8 DIN 125	2
3	33124	SNAPRING		2
4	33153	ROCKER	ARM	4
5	31804	NUT	JAM M10 X 1.25	4
6	33154	SCREW	ADJUSTING	4
7	33155	PUSHROD		4
8	33156	TAPPET		4
9	33150	SHAFT	ROCKER-ASSEMBLY	1
10	33151	SPRING	ROCKER SHAFT	1
11	33152	BRACKET	ROCKER SHAFT	2
12	30241	LOCK	VALVE SPRING RETAINER	8
13	33149	RETAINER	VALVE SPRING	4
14	33119	SPRING	VALVE	4
15	30242	SEAL	OIL	4
16	33148	VALVE	EXHAUST	2
17	33147	VALVE	INTAKE	2
18	33179	CAMSHAFT		1
19	30274	KEY	GEAR TO CAMSHAFT	1
20	33146	GEAR	CAMSHAFT	1

WESTERBEKE 10TWC - LUBE OIL PUMP AND SUMP

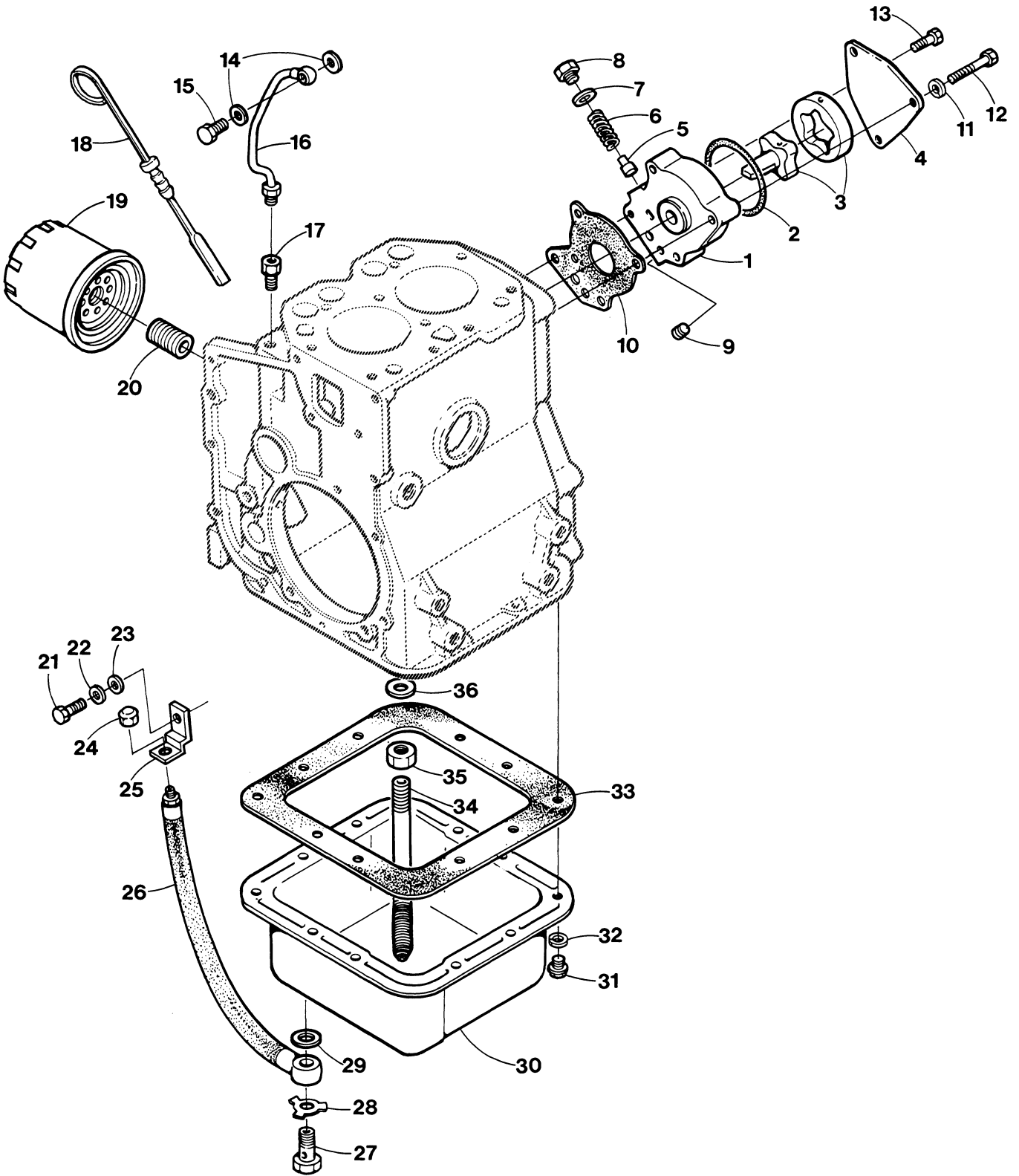

WESTERBEKE 10TWC - LUBE OIL PUMP AND SUMP

REF	PN	NAME	REMARKS	QUAN
1- 1	33189	PUMP	LUBE OIL-REF 1 THRU 9	1
1- 2	33190	BODY	LUBE OIL PUMP	1
2	33193	C-RING		1
3	33191	ROTOR	ASSEMBLY	1
4	33192	COVER	LUBE OIL PUMP	1
5	34396	VALVE	OIL RELIEF	1
6	34394	SPRING	OIL RELIEF VALVE	1
7	30284	WASHER	OIL RELIEF VALVE PLUG	1
8	34395	PLUG	OIL RELIEF VALVE	1
9	30711	PLUG	1/8	1
10	33194	GASKET	OIL PUMP TO BLOCK	1
11	31783	LOCKWASHER	M6 DIN 127	3
12	34213	CAPSCREW	M6 X 40 DIN 931	3
13	18804	CAPSCREW	M6 X 20 DIN 933	1
14	30283	GASKET	BANJO	2
15	30282	BOLT		1
16	33196	LINE	OIL-BLOCK TO HEAD	1
17	30204	CONNECTOR	OIL LINE	1
18	33170	DIPSTICK	OIL LEVEL	1
19	30220	FILTER	LUBE OIL	1
20	30214	NIPPLE	OIL FILTER TO BLOCK	1
21	33351	CAPSCREW	M6 X 60 DIN 931	1
22	31783	LOCKWASHER	M6 DIN 127	1
23	31784	WASHER	FLAT M6 DIN 125	1
24	24905	CAP	SUMP DRAIN HOSE	1
25	24922	BRACKET	SUMP DRAIN HOSE	1
26	33056	HOSE	SUMP DRAIN	1
27- 1	24782	BOLT	BANJO-SUMP DRAIN	1
27- 2		LOC-TITE	NO 242 MUST BE USED ON THREADS	
28	24913	TABWASHER		1
29	24973	WASHER	BANJO	1
30	33168	SUMP	LUBE OIL	1
31	31825	CAPSCREW	M6 X 12 DIN 933	10
32	31783	LOCKWASHER	M6 DIN 127	10
33	33169	GASKET	SUMP TO BLOCK	1
34	33195	TUBE	OIL PICKUP	1
35	31807	NUT	JAM M12 X 1.25	1
36	30290	WASHER	OIL PICKUP TUBE	1

# WESTERBEKE 10TWO - COOLING SYSTEM

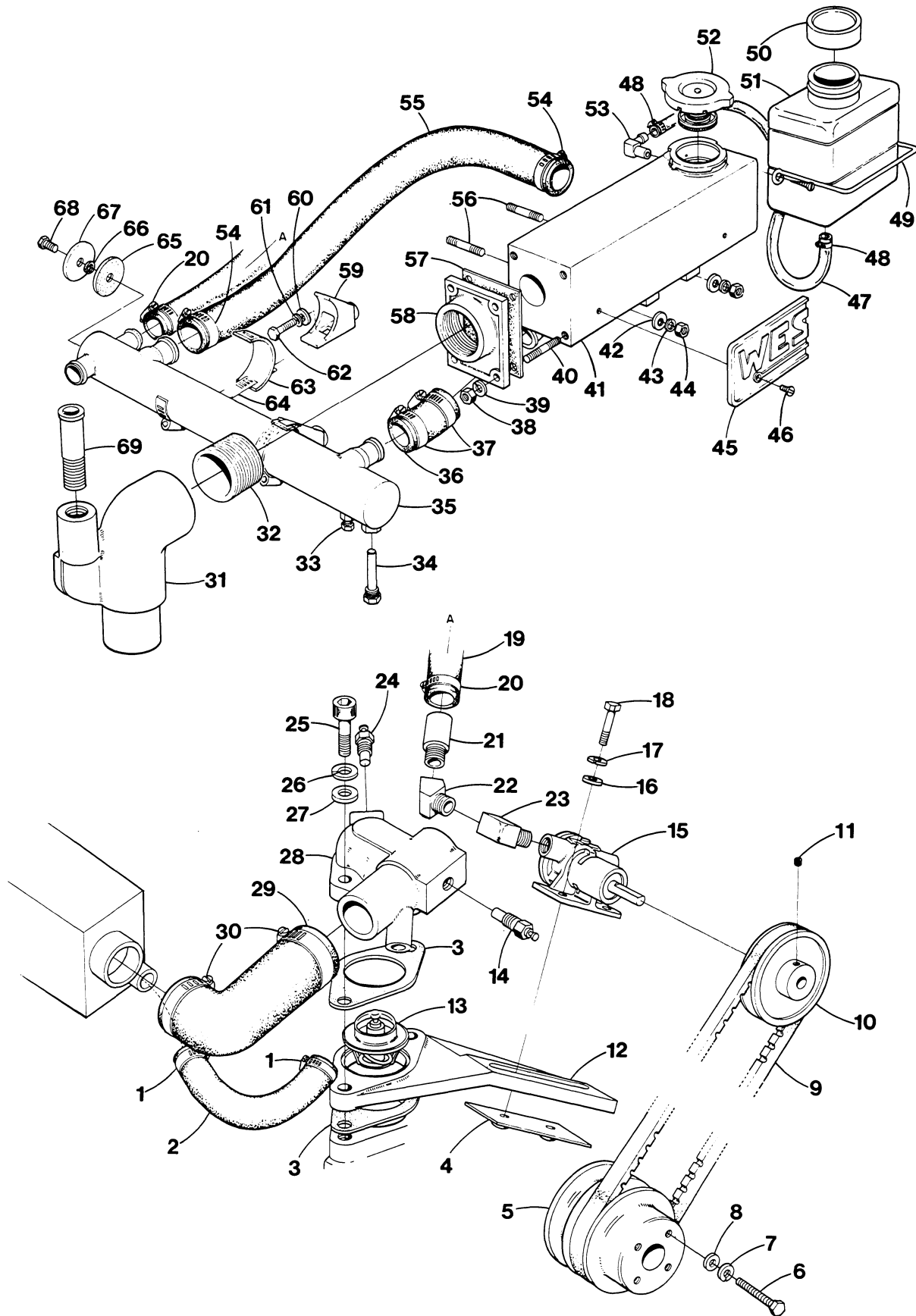

WESTERBEKE 10TWO - COOLING SYSTEM

REF	PN	NAME	REMARKS	QUAN
1	11386	CLAMP	HOSE	2
2	19059	HOSE	7/8 WIRE INSERTED-INCHES REQD	10
3	32586	GASKET	THERMOSTAT	2
4	33018	PLATE	SEA WATER PUMP ADJUSTING	1
5	32496	PULLEY	FRESH WATER PUMP	1
6	32913	CAPSCREW	M6 X 15 DIN 933	4
7	31783	LOCKWASHER	M6 DIN 127	4
8	31784	WASHER	M6 DIN 125	4
9	32942	BELT	SEA WATER PUMP	1
10	32616	PULLEY	SEA WATER PUMP	1
11	11357	SETSCREW		1
12	32494	BRACKET	SEA WATER PUMP-THERMOSTAT MOUNT	1
13	24688	THERMOSTAT		1
14- 1	30125	SWITCH	WATER TEMPERATURE-PROPULSION ALARM	1
14- 2	22131	BUSHING	1/4NPT TO 1/8NPT-PROPULSION	1
14- 3	30096	SWITCH	WATER TEMPERATURE-GENSET	1
15	32617	PUMP	SEA WATER	1
16	31753	WASHER	FLAT 1/4	2
17	31752	LOCKWASHER	1/4	2
18	31506	CAPSCREW	1/4NC X 1-1/4	2
19	19059	HOSE	7/8 WIRE INSERTED-INCHES REQD	13
20	11386	CLAMP	HOSE	2
21	32947	NIPPLE	HOSE 3/8NPT TO 7/8 HOSE	1
22	13337	ELBOW	3/8NPT 45 DEGREE STREET	1
23	13338	ELBOW	3/8NPT 90 DEGREE STREET	1
24	23571	SENDER	WATER TEMPERATURE	1
25	31259	CAPSCREW	M8 X 45 DIN 912	2
26	31786	LOCKWASHER	M8 DIN 127	2
27	31787	WASHER	M8 DIN 125	2
28- 1	32994	HOUSING	THERMOSTAT-PROPULSION WITH FLOWCONTROLLE	1
28- 2	32570	HOUSING	THERMOSTAT-GENSET	1
29	24334	ELBOW	HOSE	1
30	21878	CLAMP	HOSE	2
31- 1	15985	ELBOW	WATER INJECTED EXHAUST-PROPULSION	1
31- 2	33067	ELBOW	WATER INJECTED EXHAUST-GENSET	1
32	20439	NIPPLE	1.5NPT CLOSE	1
33- 1	11471	PETCOCK		1
33- 2	19369	PLUG	1/8NPT HEX HEAD BRASS	1
34	11885	ZINC		1
35	32501	EXCHANGER	HEAT	1

# WESTERBEKE 10TWO - COOLING SYSTEM

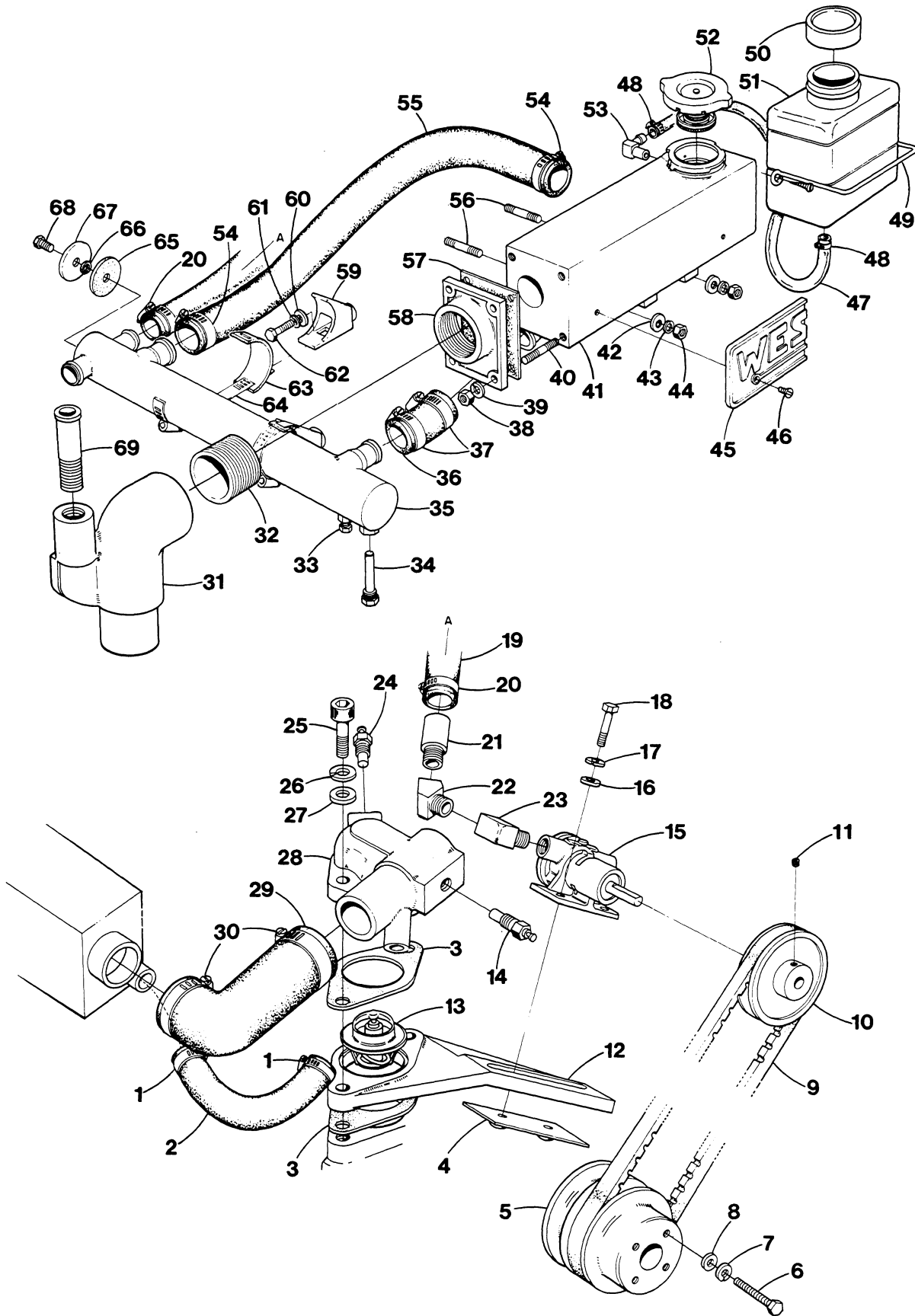

WESTERBEKE 10TWC - COOLING SYSTEM

REF	PN	NAME	REMARKS	QUAN
36	24974	HOSE	WIRE INSERTED-INCHES REQD	2
37	21878	CLAMP	HOSE	2
38	31760	NUT	5/16NF	4
39	31758	LOCKWASHER	5/16	4
40	11263	STUD		4
41- 1	32997	MANIFOLD	EXHAUST-PROPULSION	1
41- 2	32488	MANIFOLD	EXHAUST-GENSET	1
42	31787	WASHER	M8 DIN 125	4
43	31786	LOCKWASHER	M8 DIN 127	4
44	18242	NUT	M8 DIN 934	4
45	24986	NAMEPLATE		1
46		SCREW	8-32 X 1/4 OVAL HEAD-SS	2
47	24637	TUBING	INCHES REQUIRED	30
48	24906	CLAMP	HOSE	2
49	24786	STRAP	TANK MOUNTING	1
50	24858	CAP	COOLANT RECOVERY TANK	1
51- 1	24704	TANK	COOLANT RECOVERY	1
51- 2	24977	KIT	COOLANT RECOVERY REF 47-51	1
52	24306	CAP	PRESSURE	1
53	24907	ELBOW	MANIFOLD TO TUBING	1
54	11405	CLAMP	HOSE	2
55	32926	HOSE	EXCHANGER TO PUMP	1
56	15830	STUD	M8 X 25 DIN 939	4
57	32585	GASKET	MANIFOLD END FLANGE	1
58	32622	FLANGE	MANIFOLD END	1
59	32582	BRACKET	EXCHANGER MOUNT	2
60	31765	WASHER	FLAT 3/8	2
61	31764	LOCKWASHER	3/8	2
62	31605	CAPSCREW	3/8NC X 1	2
63	33487	WASHER	EXCHANGER VIBRATION	2
64	11411	CLAMP	EXCHANGER MOUNTING	2
65	33298	GASKET	EXCHANGER END COVER	2
66	19321	C-RING	EXCHANGER END COVER	2
67	33297	COVER	EXCHANGER END	2
68	33402	CAPSCREW	5/16NC X 1/2 BRASS	2
69	32230	NIPPLE	1/2NPT TO 7/8 HOSE	1



WESTERBEKE 10TWO - SEA WATER PUMP

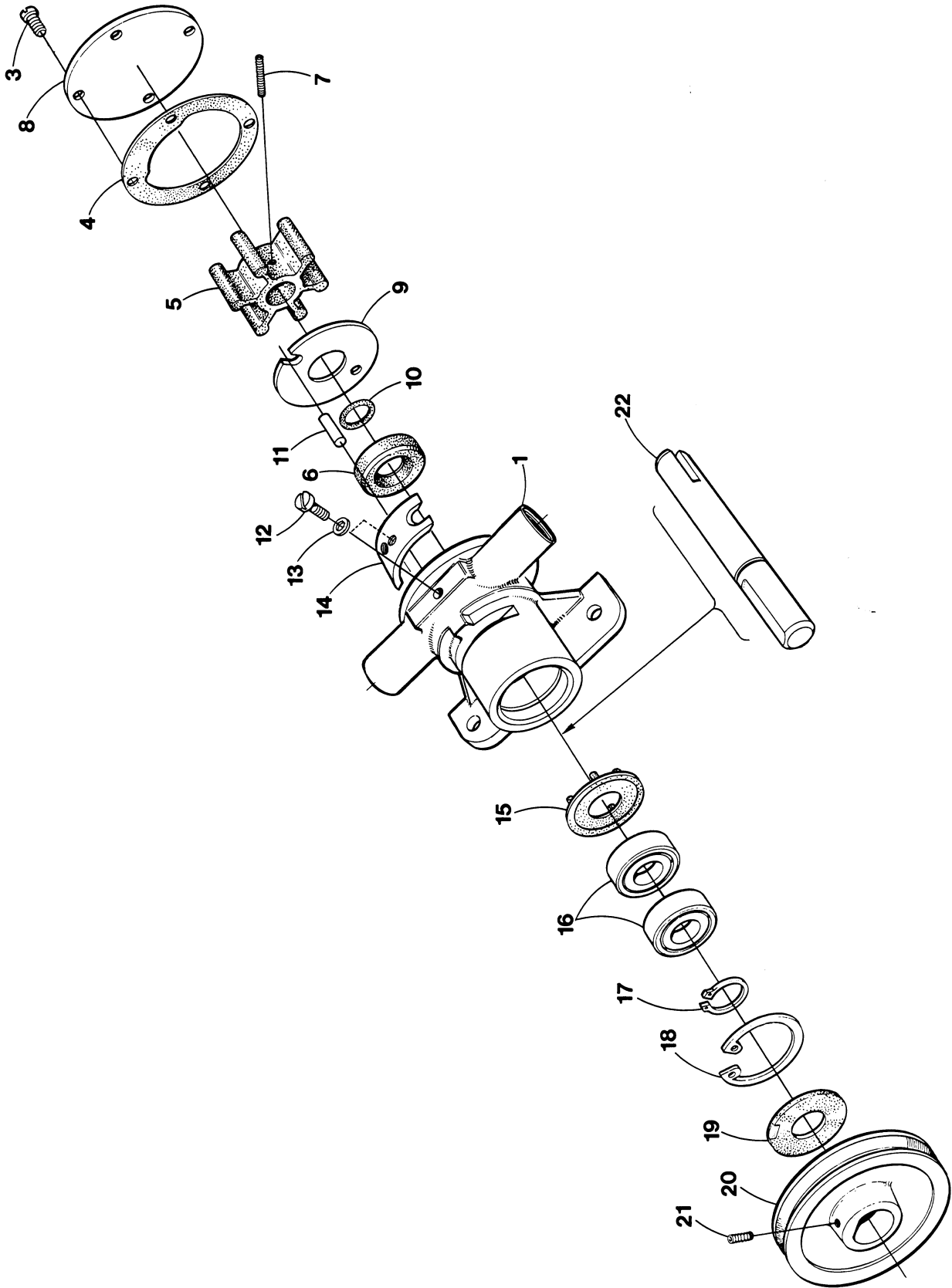

WESTERBEKE 10TWO - SEA WATER PUMP

REF	PN	NAME	REMARKS	QUAN
1	32617	PUMP	SEA WATER EXCLUDING PULLEY	1
2	32620	KIT	IMPELLER INCL REF 3 THRU 7	1
3		SCREW	COVER-SEE KIT REF 2	4
4	33032	GASKET	IMPELLER COVER	1
5		IMPELLER	SEE KIT REF 2	1
6		SEAL	SEE KIT REF 2	1
7		SCREW	IMPELLER-SEE KIT REF 2	1
8	32625	COVER	IMPELLER	1
9	33036	PLATE	WEAR	1
10		C-RING		1
11		DOWEL		1
12	33038	SCREW	CAM	1
13	33037	WASHER		1
14	33031	CAM		1
15		COVER	BEARING-INNER	1
16		BEARING		2
17		CIRCLIP		1
18		CIRCLIP		1
19		COVER	BEARING-OUTER	1
20	32616	PULLEY	SEA WATER PUMP DRIVE	1
21	11357	SETSCREW		1
22		SHAFT		1
23- 1		NOTE	ABSENCE OF PART NUMBER INDICATES ITEM	
23- 2			NOT AVAILABLE AS LOOSE PART	

# WESTERBEKE 10TWO - FRESH WATER PUMP - ALTERNATOR

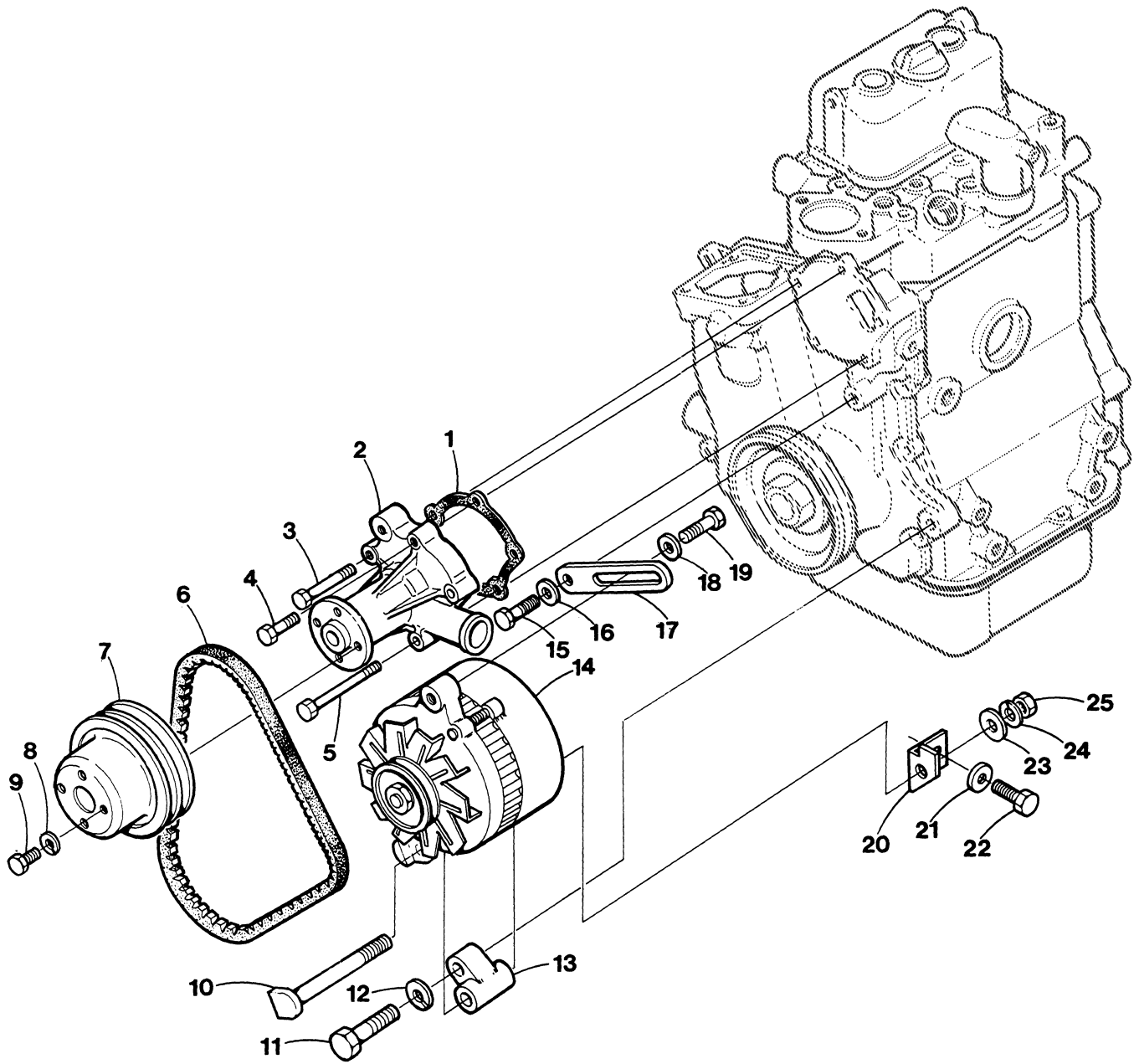

WESTERBEKE 10TWO - FRESH WATER PUMP - ALTERNATOR

REF	PN	NAME	REMARKS	QUAN
1	33198	GASKET	FRESH WATER PUMP TO BLOCK	1
2	33197	PUMP	FRESH WATER	1
3	34397	CAPSCREW	M6 X 65 DIN 931	3
4	13590	CAPSCREW	M6 X 30 DIN 933	1
5	34398	CAPSCREW	M6 X 80 DIN 931	1
6	13585	BELT	ALTERNATOR AND FRESH WATER PUMP	1
7	32496	PULLEY	FRESH WATER PUMP	1
8	31783	LOCKWASHER	M6 DIN 127	4
9	32913	CAPSCREW	M6 X 15 DIN 933	4
10	33285	BOLT	ALTERNATOR MOUNT	1
11	18811	CAPSCREW	M8 X 40 DIN 931	1
12	31786	LOCKWASHER	M8 DIN 127	1
13	32420	BRACKET	ALTERNATOR MOUNT	1
14	32939	ALTERNATOR	35AMP 12VDC	1
15	17196	CAPSCREW	M8 X 20 DIN 933	1
16	31786	LOCKWASHER	M8 DIN 127	1
17	33064	STRAP	ALTERNATOR ADJUSTING	1
18- 1	33381	WASHER	ADJUSTING STRAP	1
18- 2	31786	LOCKWASHER	M8 DIN 127	1
19	17196	CAPSCREW	M8 X 20 DIN 933	1
20	32422	BRACKET	ALTERNATOR BRACKET SUPPORT	1
21	19262	LOCKWASHER	M10 DIN 127	1
22	24952	CAPSCREW	M10 X 1.25 X 25 DIN 961	1
23	31787	WASHER	FLAT M8 DIN 125	1
24	31786	LOCKWASHER	M8 DIN 127	1
25	18242	NUT	M8 DIN 934	1

WESTERBEKE 10TWO - GOVERNOR

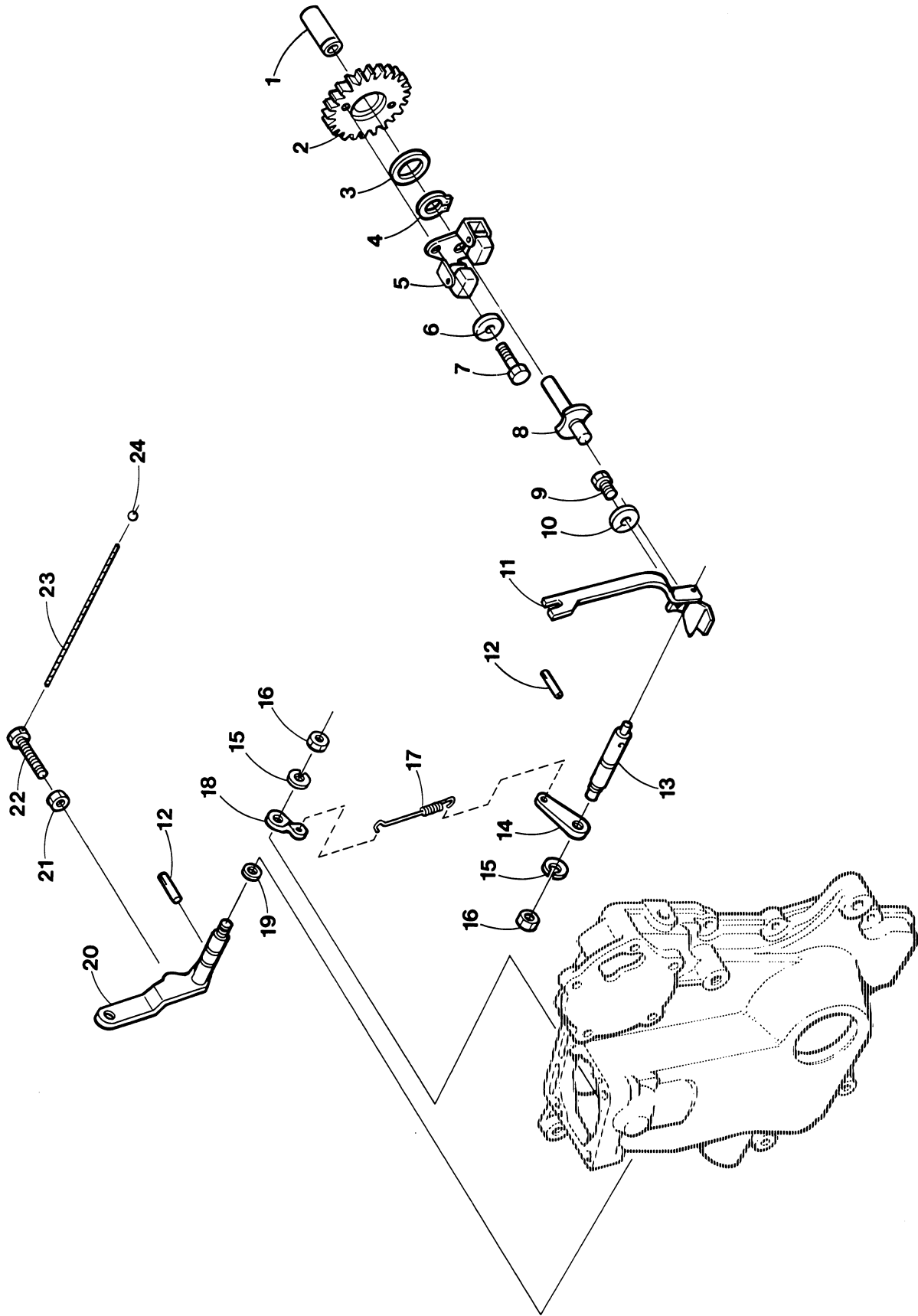

WESTERBEKE 10TWO - GOVERNOR

REF	PN	NAME	REMARKS	QUAN
1	33203	BUSHING	GOVERNOR	1
2	33184	GEAR	GOVERNOR	1
3	33199	WASHER		1
4	33122	SNAPRING		1
5	33187	WEIGHT	ASSAMBLY-GOVERNOR	1
6	31783	LOCKWASHER	M6 DIN 127	2
7	15816	CAPSCREW	M6 X 10	2
8	33201	SHAFT	ASSEMBLY-SLIDING	1
9	31810	CAPSCREW	M6 X 14 DIN 933	1
10	31783	LOCKWASHER	M6 DIN 127	1
11	33186	LEVER	FORK	1
12	30208	PIN	GRCOVED	2
13	30320	SHAFT	GOVERNOR	1
14	33120	LEVER	GOVERNOR SPRING	1
15	31786	LOCKWASHER	M8 DIN 127	2
16	31802	NUT	JAF-M8	2
17- 1	33188	SPRING	GOVERNOR-MARINE	1
17- 2	33125	SPRING	GOVERNOR-GENERATOR	1
18	30321	LEVER	GOVERNOR SPRING	1
19	30277	C-RING		1
20	33185	LEVER	THROTTLE CONTROL	1
21	15812	NUT	M6 DIN 934	1
22	30323	BOLT	HIGH SPEED SET	1
23	30293	WIRE	SEAL HIGH SPEED BOLT	1
24	30292	SEAL	LEAD	1

WESTERBEKE 10TWO - IDLE STOP ASSEMBLY

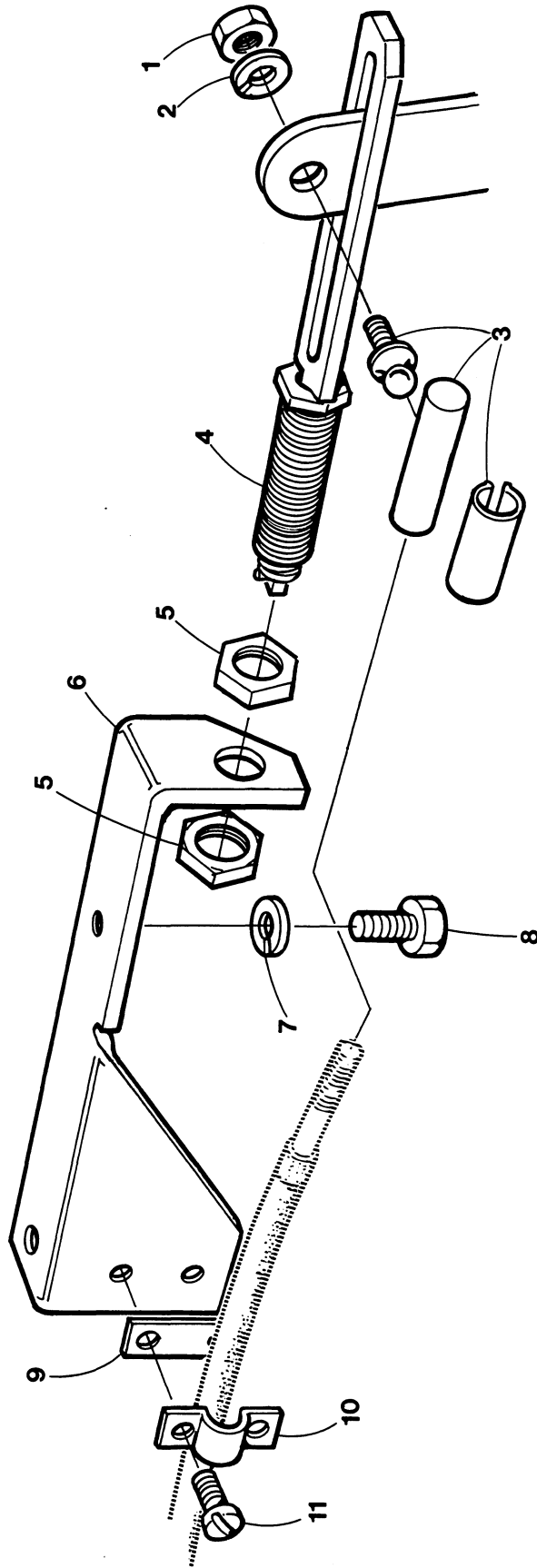

WESTERBEKE 10TWO - IDLE STCP ASSEMBLY

REF	PN	NAME	REMARKS	QUAN
1		NUT	10-32	1
2		LOCKWASHER	10	1
3	19364	BALL JOINT	THROTTLE CABLE	1
4	30169	IDLE STOP	ASSEMBLY	1
5	30051	NUT	1/2NF BRASS	2
6	32569	BRACKET	THROTTLE CABLE	1
7	31752	LOCKWASHER	1/4	2
8	31502	CAPSCREW	1/4NC X 5/8	2
9	13870	SHIM		1
10	13325	CLAMP	THROTTLE CABLE	1
11		SCREW	10-32 X 5/8	2



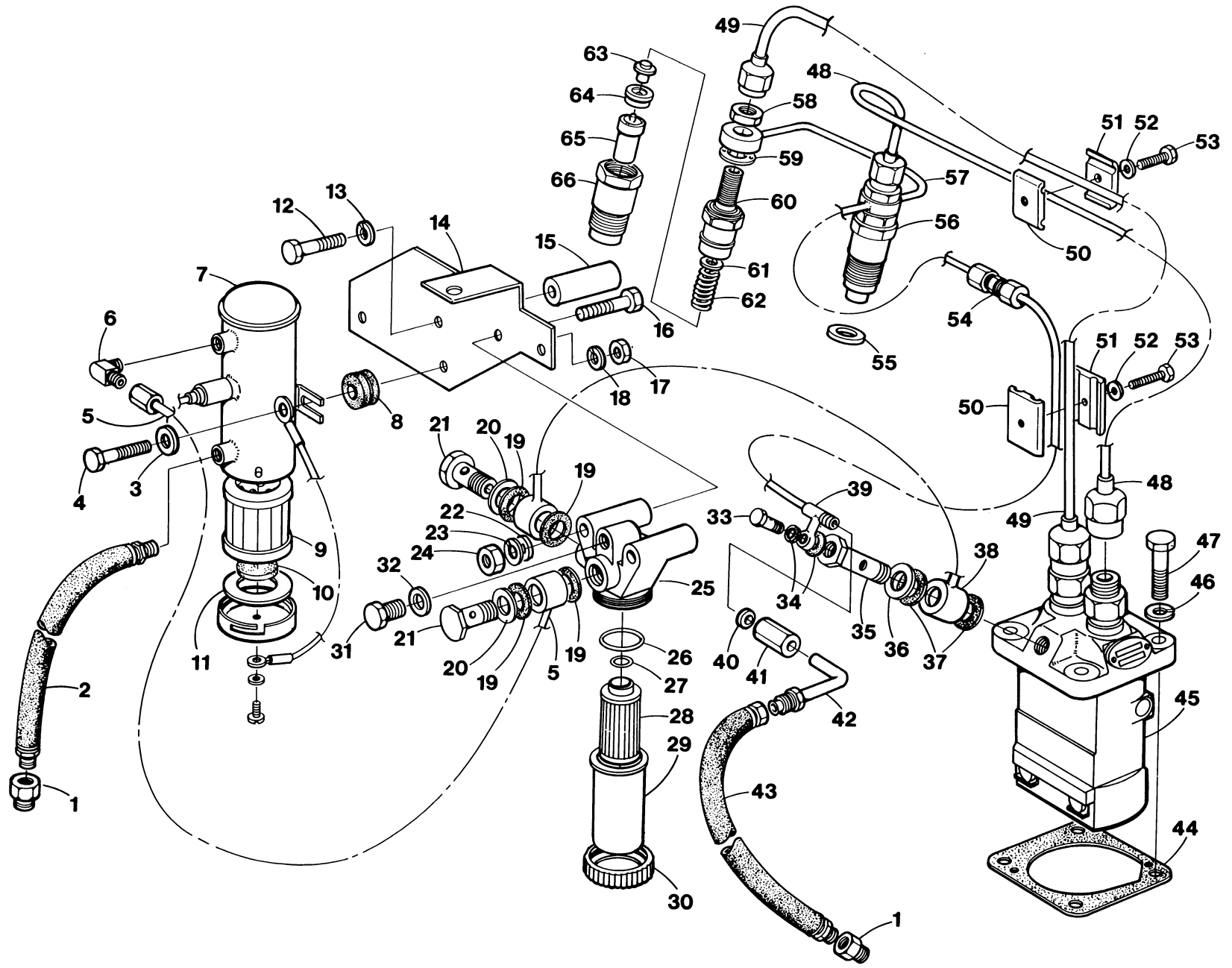

WESTERBEKE 10TWO - FUEL SYSTEM

WESTERBEKE 10TWO - FUEL SYSTEM

REF	PN	NAME	REMARKS	QUAN
1	15289	ADAPTER		2
2	30025	HOSE	FUEL SUPPLY	1
3	31753	WASHER	FLAT 1/4	2
4	31531	CAPSCREW	1/4NF X 1-1/4	2
5	32931	LINE	LIFT PUMP TO FILTER	1
6- 1	13329	ELBOW	INCLUDING COMPRESSION NUT AND FERRULE	1
6- 2	16676	NUT		1
6- 3	11597	FERRULE		1
7	24831	PUMP	FUEL LIFT 12VDC	1
8		ISOLATOR	FUEL LIFT PUMP MOUNT	2
9	30548	ELEMENT	LIFT PUMP FILTER	1
10	33792	MAGNET	LIFT PUMP	1
11	33484	GASKET	LIFT PUMP COVER	1
12	20628	CAPSCREW	M6 X 25 DIN 933	1
13	31783	LOCKWASHER	M6 DIN 127	1
14	32925	BRACKET	LIFT PUMP AND FILTER	1
15	24836	SPACER		1
16	31560	CAPSCREW	5/16NC X 2-1/4	2
17	31754	NUT	1/4NF	2
18	31752	LOCKWASHER	1/4	2
19	30291	WASHER	BANJO M14	4
20	24972	WASHER	M14 ALUMINUM	2
21	24984	BOLT	BANJO	2
22	31759	WASHER	FLAT 5/16	2
23	31758	LOCKWASHER	5/16	2
24	31756	NUT	5/16NC	2
25- 1	30210	FILTER	FUEL	1
25- 2	30211	HEAD	FUEL FILTER	1
26	30705	O-RING	FUEL FILTER CUP	1
27- 1	30201	O-RING	FUEL FILTER	1
27- 2	32406	KIT	O-RING 30201 AND 30705	1
28	30200	ELEMENT	FUEL FILTER	1
29	30199	CUP	FUEL FILTER	1
30	30212	RETAINER	FUEL FILTER CUP	1
31	30213	SCREW	FUEL FILTER BLEED	1
32	30289	WASHER	FUEL FILTER BLEED	1
33	16988	BOLT	BANJO M8	1
34	30289	WASHER	BANJO M8	2
35	24916	BOLT	BANJO	1
36	24972	WASHER	M14 ALUMINUM	1
37	30291	WASHER	BANJO M14	2
38	32933	LINE	FILTER TO INJECTION PUMP	1
39	32938	LINE	INJECTOR LEAK-OFF TO PUMP	1
40	13344	FERRULE		1
41	13343	NUT		1
42	33383	TUBE	INCL NUT AND FERRULE	1
43	20950	HOSE	FUEL RETURN	1

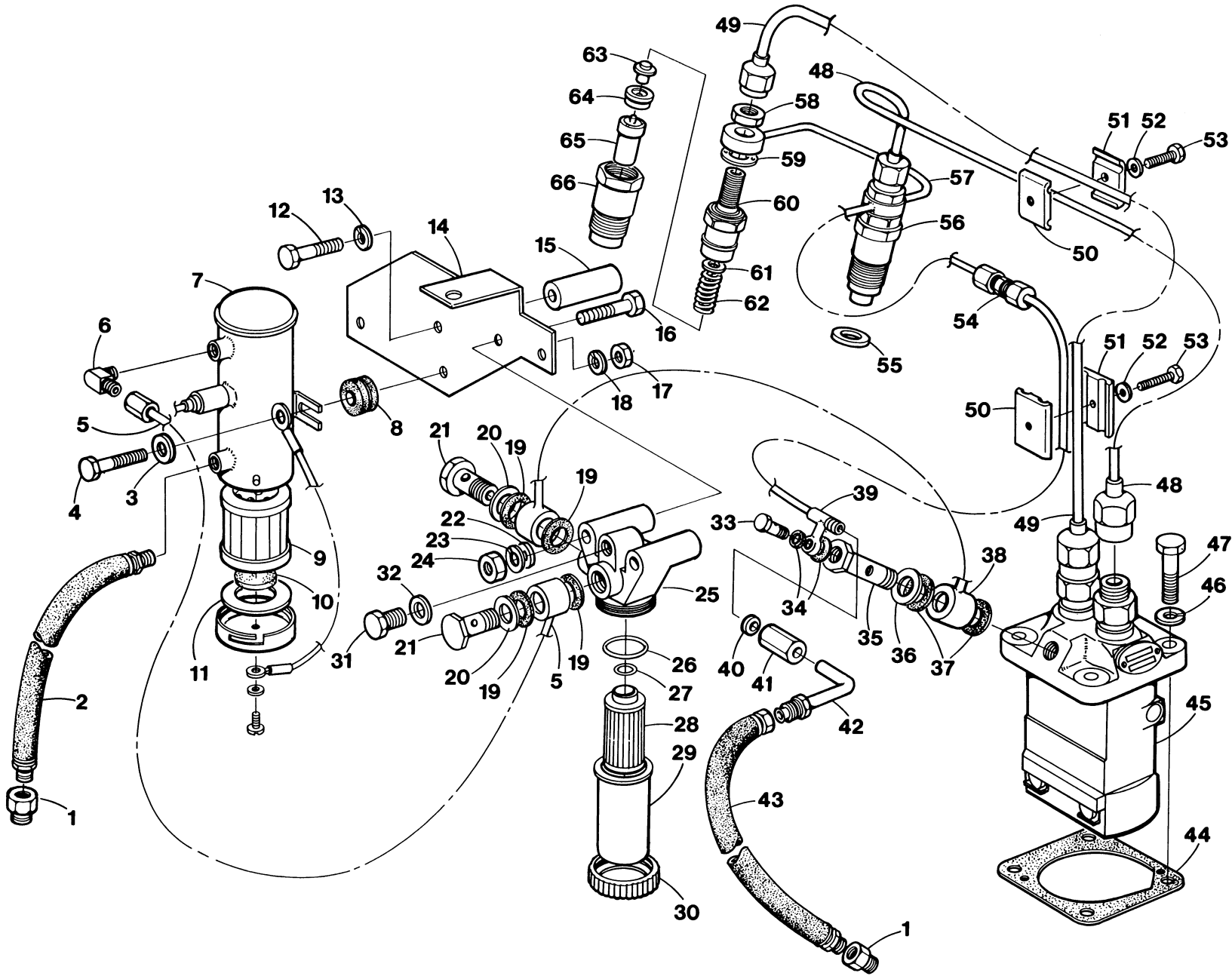

WESTERBEKE 10TWO - FUEL SYSTEM

WESTERBEKE 10TWO - FUEL SYSTEM

REF	PN	NAME	REMARKS	QUAN
44- 1	30310	SHIM	ADJUSTING 0.2MM	AR
44- 2	30311	SHIM	ADJUSTING 0.3MM	AR
44- 3	30312	SHIM	ADJUSTING 0.4MM	AR
44- 4	31301	SHIM	ADJUSTING 0.5MM	AR
44- 5	31302	SHIM	ADJUSTING 0.6MM	AR
44- 6	31303	SHIM	ADJUSTING 0.7MM	AR
44- 7	30313	SHIM	ADJUSTING 0.8MM	AR
44- 8	31304	SHIM	ADJUSTING 0.9MM	AR
44- 9	30314	SHIM	ADJUSTING 1.0MM	AR
45	33181	PUMP	FUEL INJECTION	1
46	31786	LOCKWASHER	M8 DIN 127	4
47	17196	CAPSCREW	M8 X 20 DIN 933	4
48	33182	LINE	INJECTOR 1	1
49	33183	LINE	INJECTOR 2	1
50	30316	CLAMP	FUEL LINE-THREADED	2
51	30315	CLAMP	FUEL LINE	2
52	31783	LOCKWASHER	M6 DIN 127	2
53	20628	CAPSCREW	M6 X 25 DIN 933	2
54- 1	24600	UNION	COMPRESSION INCL NUTS AND FERRULES	1
54- 2	13343	FERRULE		2
54- 3	13344	NUT		2
55	30193	GASKET	INJECTOR	2
56	33157	INJECTOR		2
57	33002	LINE	INJECTOR LEAK-OFF	1
58	33206	NUT	LINE TO INJECTOR	2
59	33345	WASHER	INJECTOR TO LINE	2

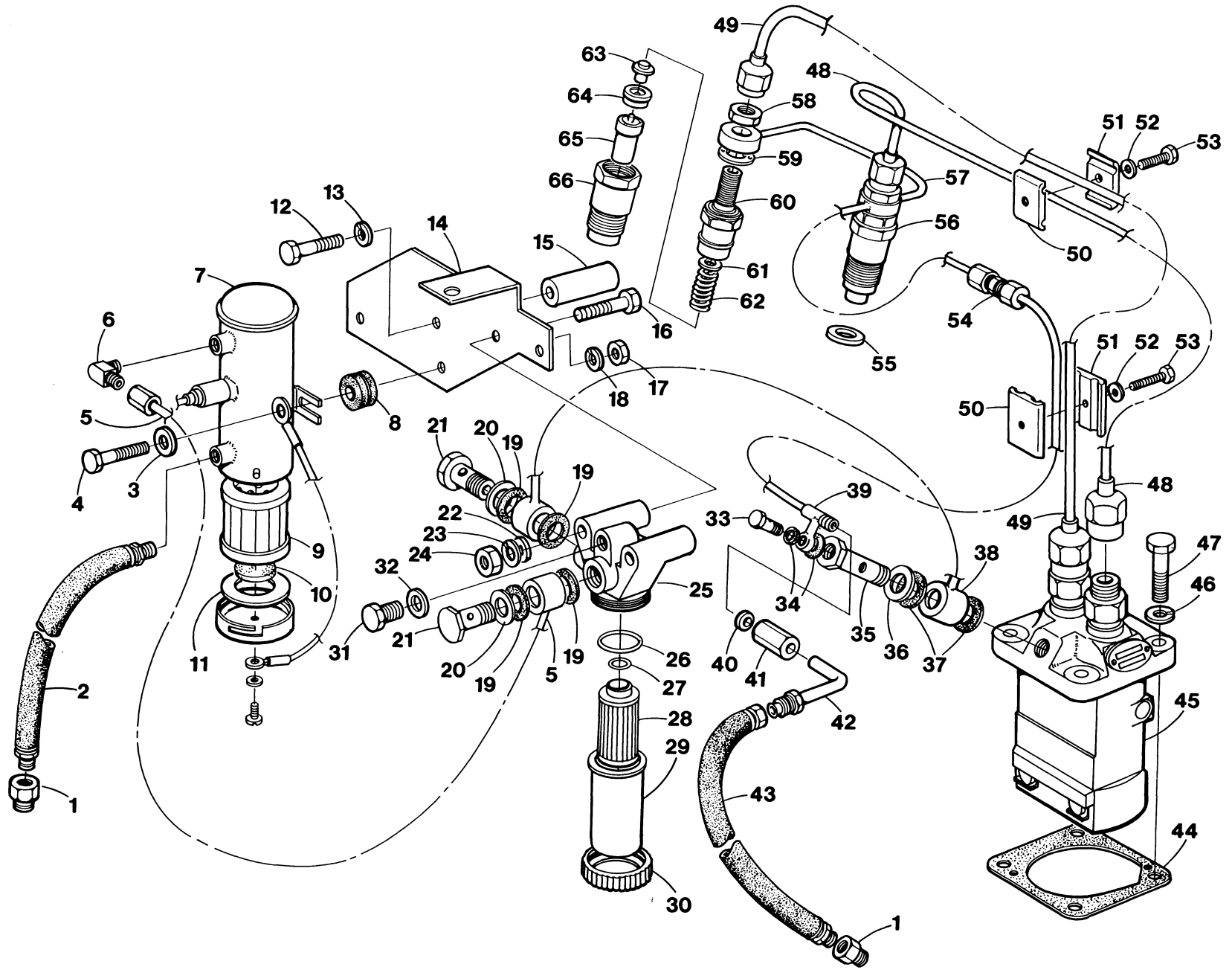

WESTERBEKE 10TWO - FUEL SYSTEM

WESTERBEKE 10TWO - FUEL SYSTEM

REF	PN	NAME	REMARKS	QUAN
00	33450	BODY	INJECTOR	2
01- 1	33428	SHIM	1.00MM	AR
01- 2	33429	SHIM	1.05MM	AR
01- 3	33430	SHIM	1.10MM	AR
01- 4	33431	SHIM	1.15MM	AR
01- 5	33432	SHIM	1.20MM	AR
01- 6	33433	SHIM	1.25MM	AR
01- 7	33434	SHIM	1.30MM	AR
01- 8	33435	SHIM	1.35MM	AR
01- 9	33436	SHIM	1.40MM	AR
01-10	33437	SHIM	1.45MM	AR
01-11	33438	SHIM	1.50MM	AR
01-12	33439	SHIM	1.55MM	AR
01-13	33440	SHIM	1.60MM	AR
01-14	33441	SHIM	1.65MM	AR
01-15	33442	SHIM	1.70MM	AR
01-16	33443	SHIM	1.75MM	AR
01-17	33444	SHIM	1.80	AR
01-18	33445	SHIM	1.85MM	AR
01-19	33446	SHIM	1.90MM	AR
01-20	33447	SHIM	1.95MM	AR
02	33448	SPRING	PRESSURE	2
03	30597	PIN	PRESSURE	2
04	30599	SPACER		2
05	30297	NOZZLE	ASSEMBLY	2
06	33449	NUT	RETAINING	2

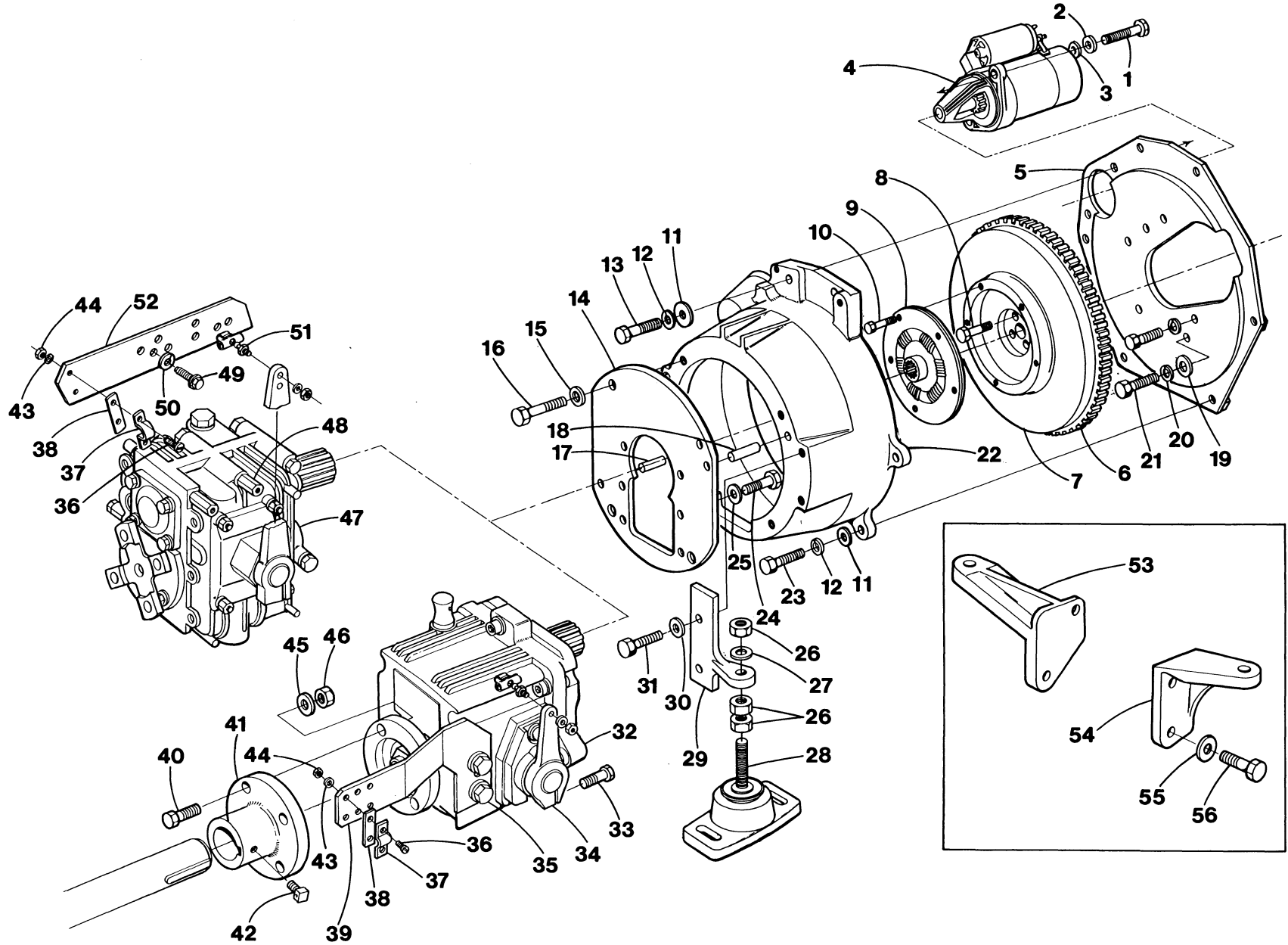

WESTERBEKE 10TWO - PROPULSION BACK END AND MOUNTING SYSTEM

WESTERBEKE 10TWO - PROPULSION BACK END AND MOUNTING SYSTEM

REF	PN	NAME	REMARKS	QUAN
1	13630	CAPSCREW	M8X25 DIN 933	2
2	31786	LOCKWASHER	M8 DIN 127	2
3	31787	WASHER	FLAT M8 DIN 125	2
4	32940	MOTOR	STARTER	1
5	32941	PLATE	BACK	1
6	32996	GEAR	RING	1
7	32482	FLYWHEEL	WITH RING GEAR	1
8	33279	BOLT	FLYWHEEL WITH FLANGE	4
9- 1	19398	DAMPER	HBW TRANSMISSION	1
9- 2	30940	DAMPER	BW TRANSMISSION	1
9- 3	32948	SPACER	BW TRANSMISSION-DAMPER TO FLYWHEEL	1
10- 1	24778	CAPSCREW	HBW DAMPER TO FLYWHEEL	5
10- 2	32965	CAPSCREW	BW DAMPER TO FLYWHEEL	5
11	31789	WASHER	FLAT M10 DIN 125	6
12	19262	LOCKWASHER	M10 DIN 127	6
13	24955	CAPSCREW	M10X1.25X45 DIN 960	1
14	32928	ADAPTER	HBW-BW TRANSMISSION TO HOUSING	1
15	31770	LOCKWASHER	7/16	4
16	31655	CAPSCREW	7/16NC X 1	4
17	31377	DOWEL	TUBULAR-BW3	2
18	19439	DOWEL	ADAPTER TO HOUSING	2
19	31789	WASHER	FLAT M10 DIN 125	1
20	19262	LOCKWASHER	M10 DIN 127	6
21	24952	CAPSCREW	M10X1.25X25 DIN 961	6
22	32334	HOUSING	FLYWHEEL	1
23- 1	24953	CAPSCREW	M10X1.25X35 DIN 961	4
23- 2	24956	CAPSCREW	M10X1.25X50 DIN 960-BATTERY GROUND	1
23- 3	24950	NUT	M10X1.25 DIN 934-BATTERY GROUND	1
24- 1	20650	CAPSCREW	M8X18 DIN 933-HBW	6
24- 2	31452	CAPSCREW	M8X22 DIN 933-BW	6
25	31788	LOCKWASHER	M8 DIN 137B-HBW-BW	6
26	31826	NUT	5/8NF-JAM	12
27	31827	LOCKWASHER	5/8	4
28	32013	ISOLATOR		4
29	32580	MOUNT	REAR	2
30	31764	LOCKWASHER	3/8	4
31	31605	CAPSCREW	3/8NC X 1	4
32	30949	BW GEAR	2 TO 1	1
33	31555	CAPSCREW	5/16NC X 1	1
34	32626	LEVER	SHIFTING-BW3	1
35- 1	13629	CAPSCREW	M10X25 DIN 933	2
35- 2	19262	LOCKWASHER	M10 DIN 127	2
36		SCREW	10-32 X 5/8	2
37	13325	CLAMP	CABLE	1
38	13870	SHIM	CABLE CLAMP	1
39	33005	BRACKET	BW3 SHIFTING CABLE	1



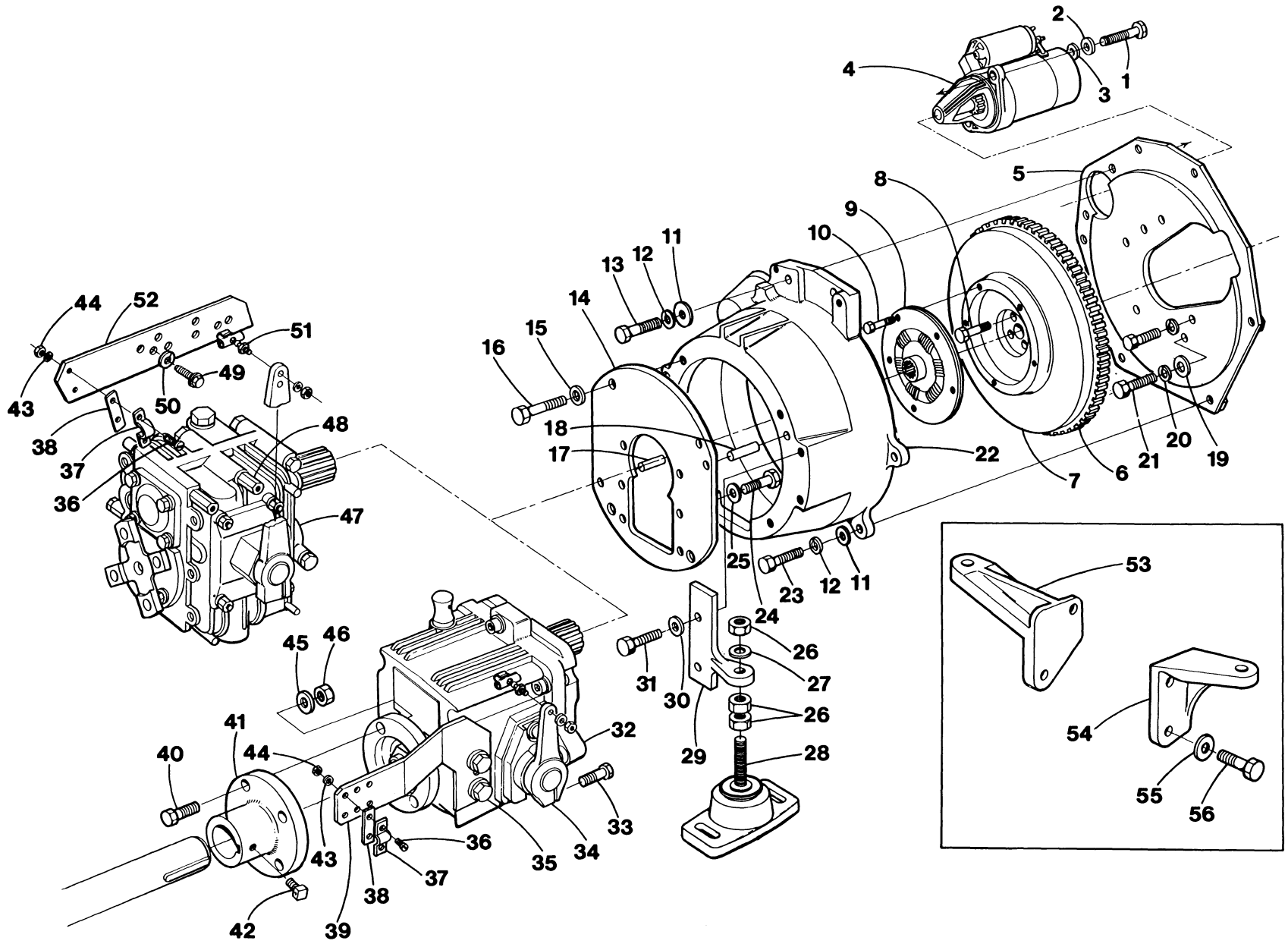

WESTERBEKE 10TW2 - PROPULSION BACK END AND MOUNTING SYSTEM

WESTERBEKE 10TWO - PROPULSION BACK END AND MOUNTING SYSTEM

REF	PN	NAME	REMARKS	QUAN
40	33537	CAPSCREW	3/8NC X 1-1/8	4
41- 1	23679	COUPLING	BW-HBW-BORE 0.75	1
41- 2	23680	COUPLING	BW-HBW-BORE 0.875	1
41- 3	23681	COUPLING	BW-HBW-BORE 1.0	1
41- 4	23682	COUPLING	BW-HBW-BORE 1.125	1
41- 5	23683	COUPLING	BW-HBW-BORE 1.25	1
41- 6	23684	COUPLING	BW-HBW-BORE 1.375	1
41- 7	23685	COUPLING	BW-HBW-BORE 1.5	1
42- 1	23651	SETSCREW	COUPLING 3/8NC X 3/4	2
42- 2	23652	SETSCREW	COUPLING 3/8NC X 1	2
43		LOCKWASHER	10	2
44		NUT	10-32	2
45	31764	LOCKWASHER	3/8	4
46	31762	NUT	3/8NC	4
47- 1	24629	FBW GEAR	2.0 TO 1	1
47- 2	31247	FBW GEAR	2.7 TO 1	1
48	30756	NUT	PILLAR-M8	2
49	13630	CAPSCREW	M8X25 DIN 933	2
50	31786	LOCKWASHER	M8 DIN 127	2
51	33482	BALL JOINT		1
52	32161	BRACKET	HBW SHIFTING CABLE	1
53	32424	MOUNT	FRONT LEFT	1
54	32426	MOUNT	FRONT RIGHT	1
55	19262	LOCKWASHER	M10 DIN 127	4
56	24952	CAPSCREW	M10 X 1.25 X 25 DIN 961	4

WESTERBEKE 10TWO - ELECTRICAL SYSTEM

SCHMATIC DIAGRAM.

WIRING DIAGRAM.  
33685

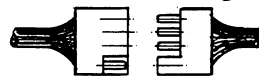
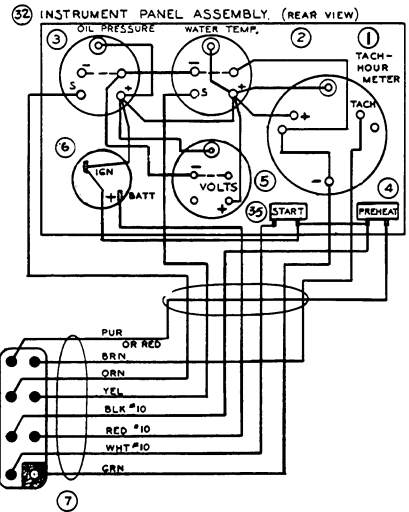
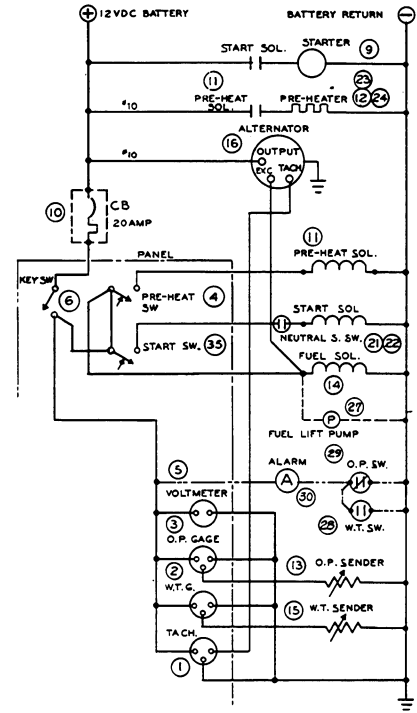
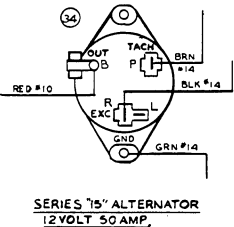
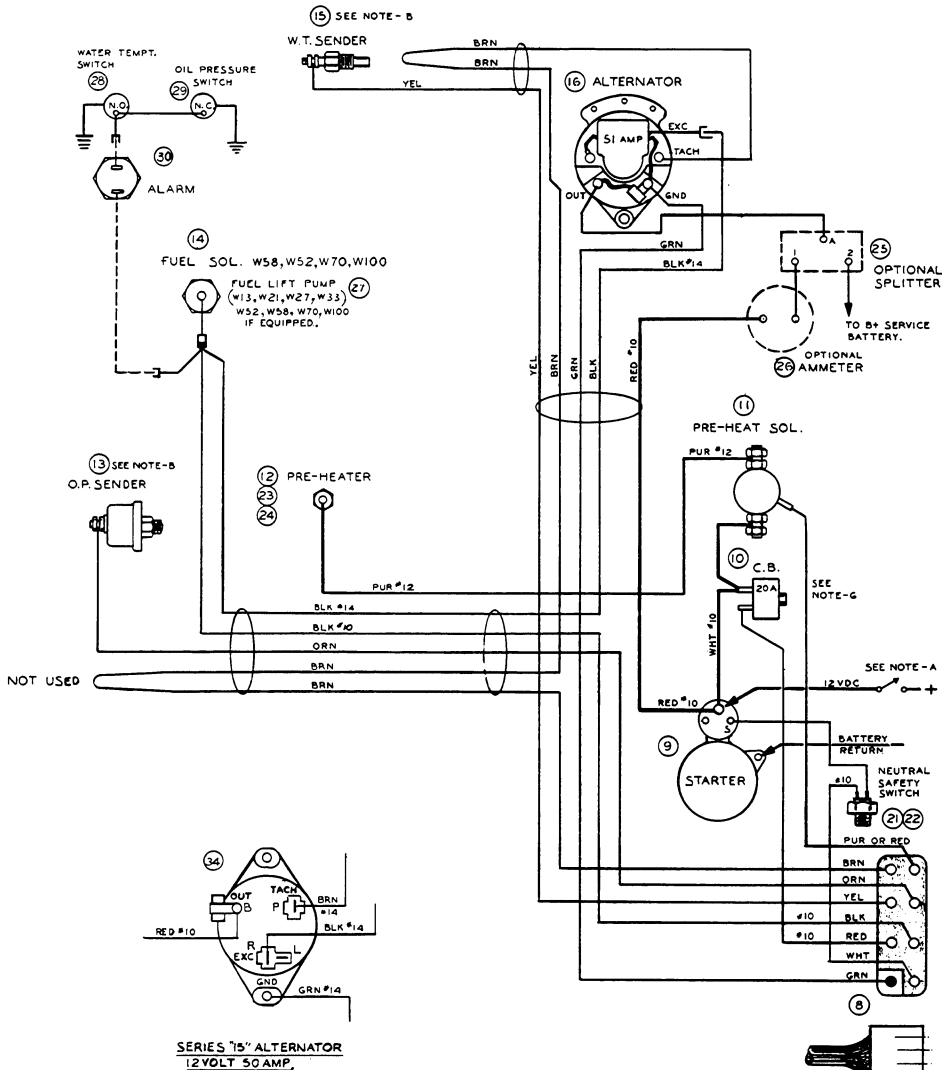

WESTERBEKE 10TWO - ELECTRICAL SYSTEM

REF	PN	NAME	REMARKS	QUAN
1	11917	METER	TACHOMETER-HOUR	1
2	11545	GAUGE	WATER TEMPERATURE	1
3	24133	GAUGE	OIL PRESSURE 0-100 PSI	1
4	33764	SWITCH	PRE-HEAT	1
5	23090	VOLTMETER	12VDC NEG GROUND	1
6	33693	SWITCH	KEY-OFF-ON	1
7	30148	CABLE	PANEL	1
8	32538	HARNESS	ENGINE	1
9	32940	MOTOR	STARTER	1
10	24683	BREAKER	CIRCUIT-20 AMP	1
11	24639	SOLENOID	PRE-HEAT	1
12- 1	33204	GLOWPLUG		2
12- 2	33205	WIRE	GLOWPLUG CONNECTING	1
13	24132	SENDER	OIL PRESSURE 0-100 PSI	1
15	23571	SENDER	WATER TEMPERATURE	1
25	20654	SPLITTER	ALTERNATOR OUTPUT-OPTIONAL	1
26	11581	AMMETER	0-60-0 OPTIONAL	1
27	24831	PUMP	ELECTRIC FUEL LIFT	1
28	30125	SWITCH	ALARM-WATER TEMPERATURE-NO	1
29	30944	SWITCH	ALARM-OIL PRESSURE-NC	1
30	13355	ALARM	BUZZER	1
32	33866	PANEL	INSTRUMENT	1
33	33865	PLATE	INSTRUMENT PANEL	1
34	32939	ALTERNATOR	35AMP-12VDC-NEG GROUND WITH REGULATOR	1
35	33764	SWITCH	START	1
30	33685	DIAGRAM	WIRING	1
31	24999	TEMPLATE	INSTRUMENT PANEL	1

WESTERBEKE 10TWO - MARINE HARNESS

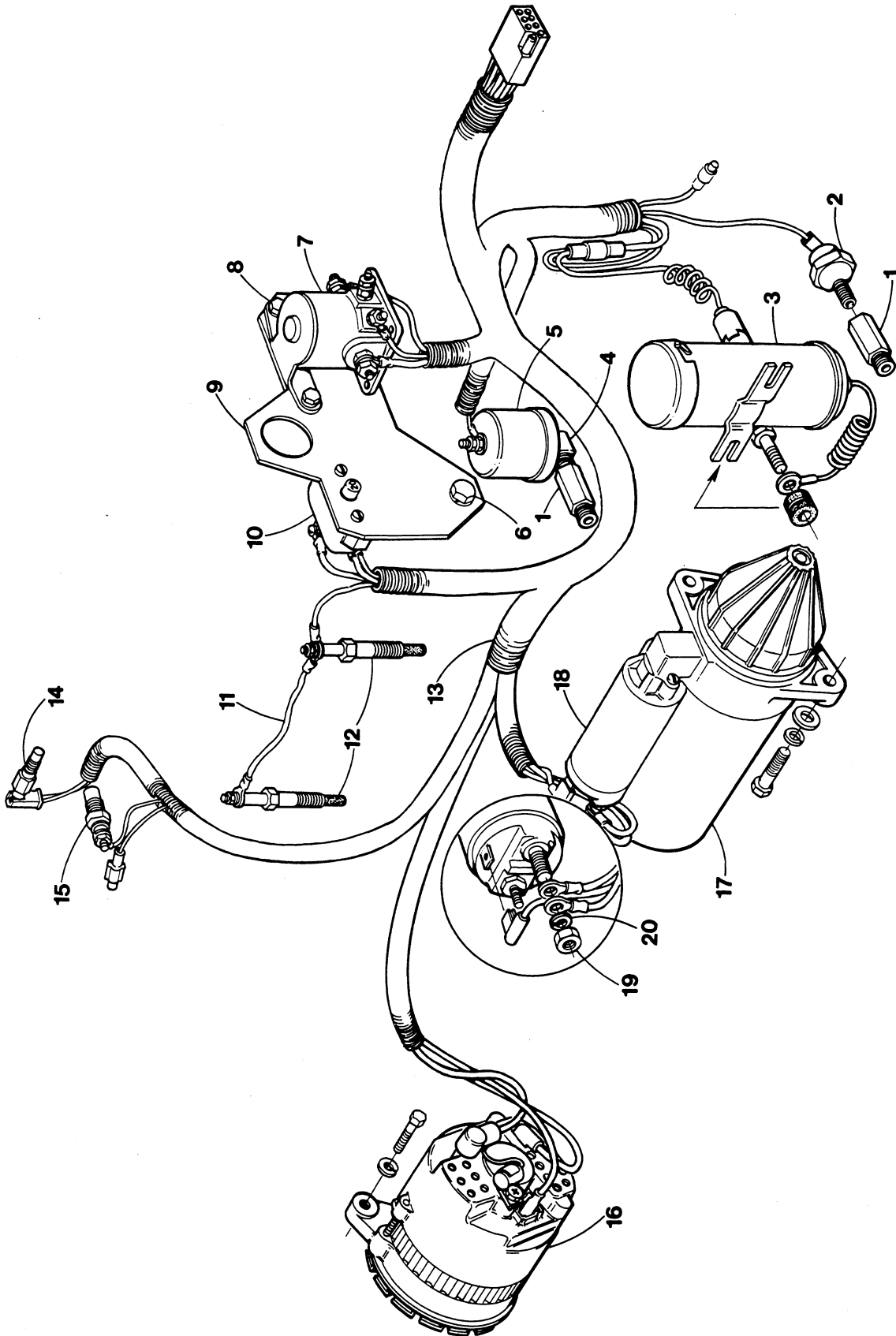

WESTERBEKE 10TWO - MARINE HARNESS

REF	PN	NAME	REMARKS	QUAN
1	24844	ADAPTER		2
2	30944	SWITCH	OIL PRESSURE-ALARM	1
3	24831	PUMP	FUEL LIFT 12VDC	1
4	11984	ELBOW	1/8NPT STREET 90	1
5	24132	SENDER	OIL PRESSURE	1
6- 1	17196	CAPSCREW	M8 X 20 DIN 933	1
6- 2	31786	LOCKWASHER	M8 DIN 127	1
7	24639	SOLENOID	PRE-HEAT 12VDC	1
8- 1	31541	CAPSCREW	1/4NC X 1/2	2
8- 2	31752	LOCKWASHER	1/4	2
8- 3	31750	NUT	1/4NC	2
9	32458	BRACKET	CIRCUIT BREAKER AND SOLENOID	1
10- 1	24683	BREAKER	CIRCUIT 20 AMP	1
10- 2		SCREW	8-32 X 7/8	2
10- 3		LOCKWASHER	8	2
11	33205	WIRE	GLOWPLUG CONNECTING	1
12	33204	GLOWPLUG	12VDC	2
13	32538	HARNESS		1
14	30125	SWITCH	WATER TEMPERATURE-ALARM	1
15	23571	SENDER	WATER TEMPERATURE	1
16	32939	ALTERNATOR	35 AMP 12VDC	1
17	32940	MOTOR	STARTER 12VDC	1
18	30245	SOLENOID	STARTER 12VDC	1
19	18242	NUT	M8 DIN 934	1
20	31786	LOCKWASHER	M8 DIN 127	1

# WESTERBEKE 10TWO - PROPULSION INSTRUMENT PANEL

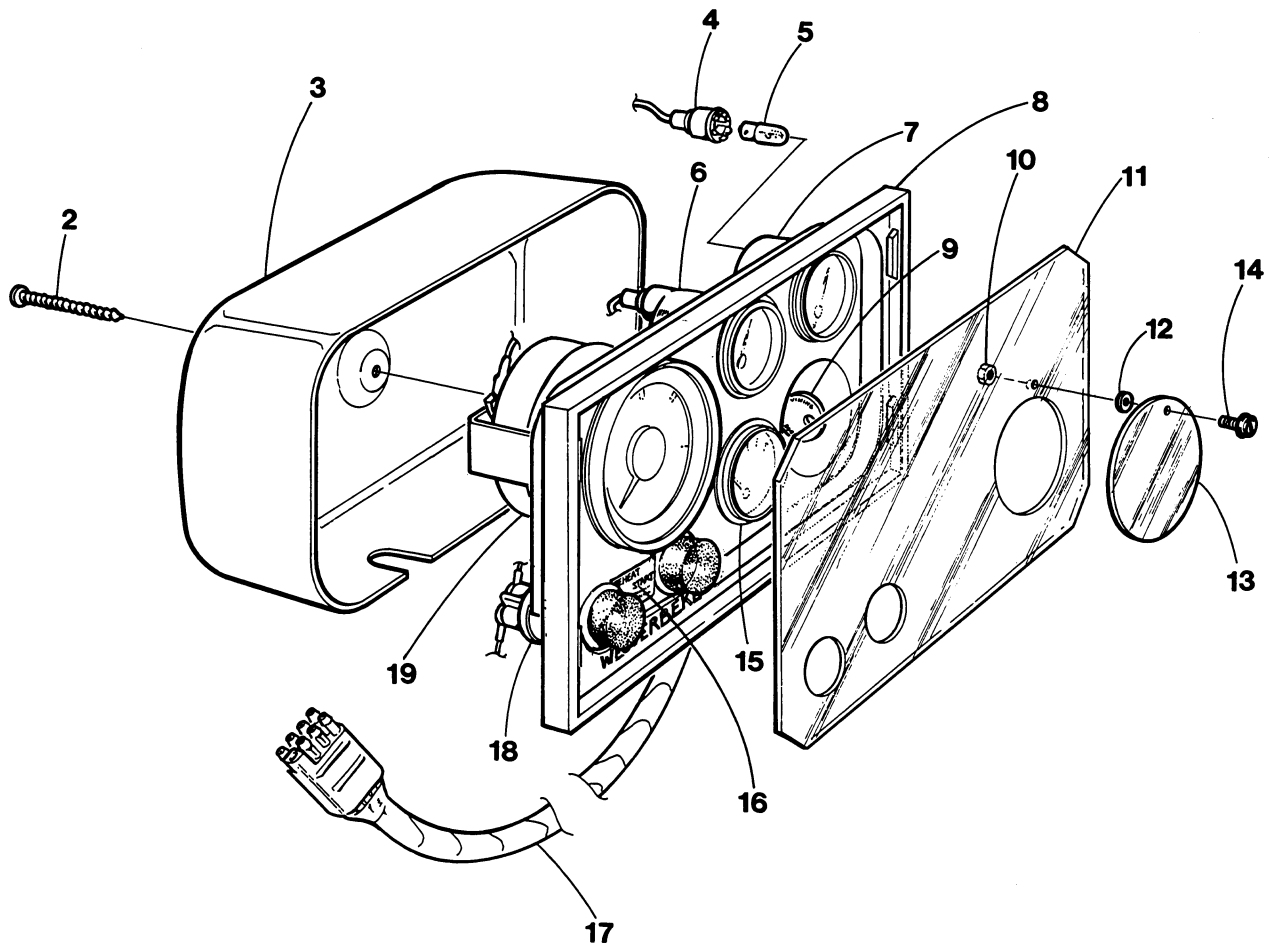

WESTERBEKE 10TWC - PROPULSION INSTRUMENT PANEL

REF	PN	NAME	REMARKS	QUAN
1	33866	PANEL	INSTRUMENT-ASSEMBLY	1
2	30913	SCREW		1
3	30119	COVER	PANEL REAR	1
4	24946	HOLDER	LAMP	4
5	24947	LAMP	INSTRUMENT METERS	4
6	11545	METER	WATER TEMPERATURE	1
7	24133	METER	OIL PRESSURE 0-100 PSI	1
8	33865	PANEL	PLATE	1
9	33693	SWITCH	KEY OFF-ON	1
10	30003	NUT	NYLON LOCKING 6-32	1
11	33684	COVER	FACEPLATE WINDOW	1
12	30002	SPACER	NYLON	1
13	24996	WINDOW	KEYSWITCH COVER	1
14	30001	SCREW	NYLON 6-32 X 1/2 WASHER HEAD	1
15	23090	VOLTMETER	12 VDC NEG GROUND	1
16	33682	DECAL	SWITCH IDENTIFICATION	1
17	30148	CABLE	PANEL TO ENGINE	1
18- 1	33764	SWITCH	PUSH BUTTON START-PREHEAT	2
18- 2	19031	CAP	SWITCH COVER REPLACEMENT	2
19	11917	METER	TACHOMETER-HOUR	1
20	24999	DRAWING	TEMPLATE TO INSTALL PANEL	1



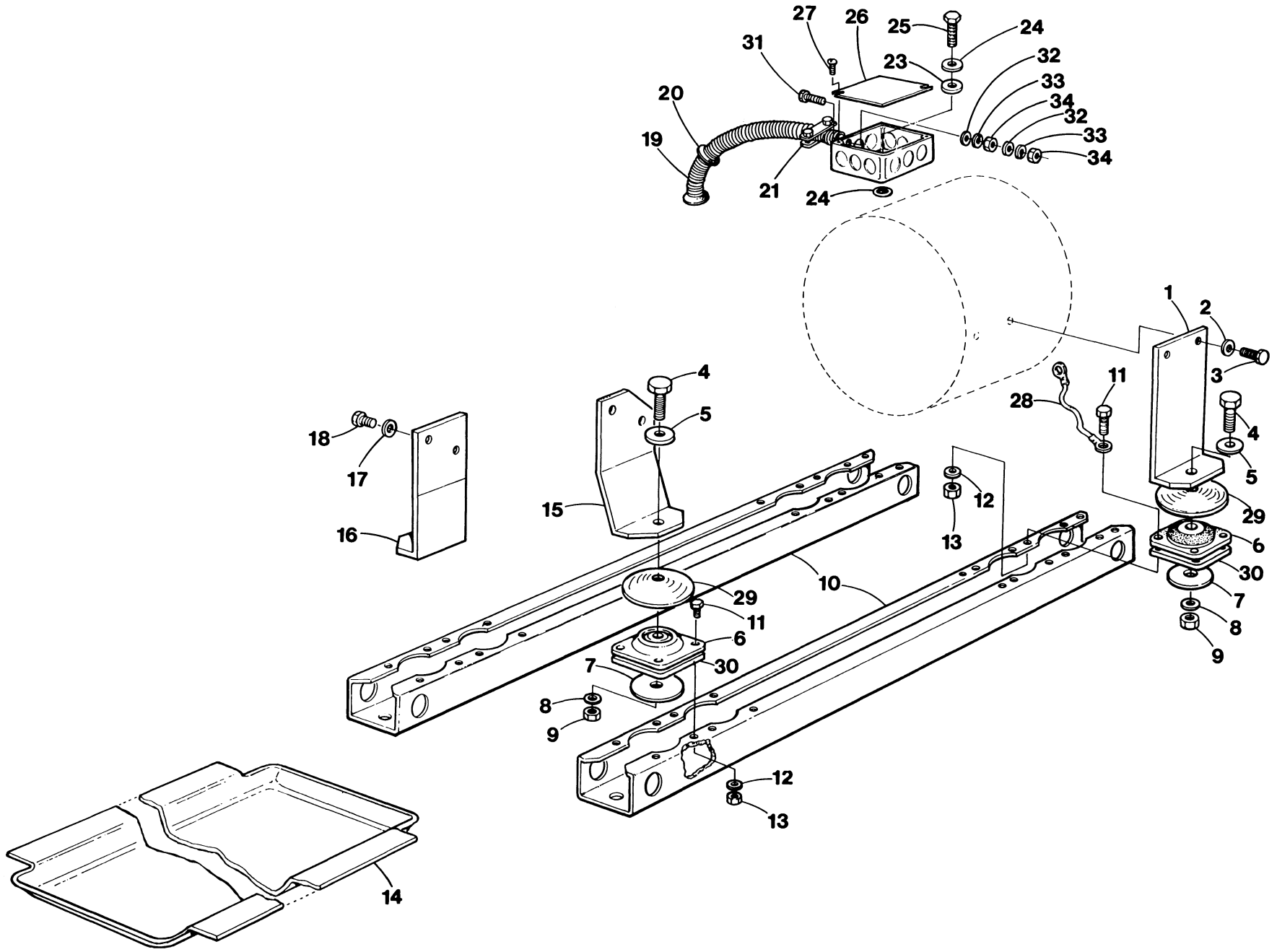

WESTERBEKE 3KW - GENERATOR MOUNTING SYSTEM

WESTERBEKE 3KW - GENERATOR MOUNTING SYSTEM

REF	PN	NAME	REMARKS	QUAN
1	32453	MOUNT	GENERATOR TO RAIL-REAR	2
2	31770	LOCKWASHER	7/16	4
3	31655	CAPSCREW	7/16NC X 1	4
4	31711	CAPSCREW	1/2NC X 2-1/2	4
5	31777	WASHER	FLAT 1/2	4
6	24776	ISOLATOR		4
7	24674	WASHER	SNUBBING	4
8	31776	LOCKWASHER	1/2	4
9	31774	NUT	1/2NC	4
10	32451	RAIL		2
11	31553	CAPSCREW	5/16NC X 3/4	16
12	31758	LOCKWASHER	5/16	16
13	31756	NUT	5/16NC	16
14	32452	DRIPTRAY		1
15	32455	MOUNT	FRONT LEFT	1
16	32454	MOUNT	FRONT RIGHT	1
17	19262	LOCKWASHER	M10 DIN 127	4
18	24952	CAPSCREW	M10 X 1.25 X 25 DIN 961	4
19	30466	CONDUIT	FLEX-INCHES REQUIRED	10
20	13776	TIEWRAP		2
21	32675	CONNECTOR	CLAMP WIRES TO BOX	1
22	33876	BOX	OUTPUT CONNECTION	1
23	31765	WASHER	FLAT 3/8	1
24	31764	LOCKWASHER	3/8	2
25	31605	CAPSCREW	3/8NC X 1	1
26	32074	COVER	OUTPUT CONNECTION BOX	1
27		SCREW	8-32 X 1/2 RH	2
28	32290	STRAP	GROUND ENGINE TO RAIL	1
29	33530	SHIELD	ISCLATOR	4
30	33574	PLATE	REINFORCING	4
31	32500	SCREW	BRASS 1/4NC X 1-1/4 GROUND CONNECTION	1
32	32499	WASHER	BRASS-FLAT	2
33	32493	LOCKWASHER	BRONZE IT 1/4	2
34	32498	NUT	1/4NC BRASS	2

# WESTERBEKE 3KW - ELECTRICAL SYSTEM

## WIRING DIAGRAM.

74700 - REVISION I

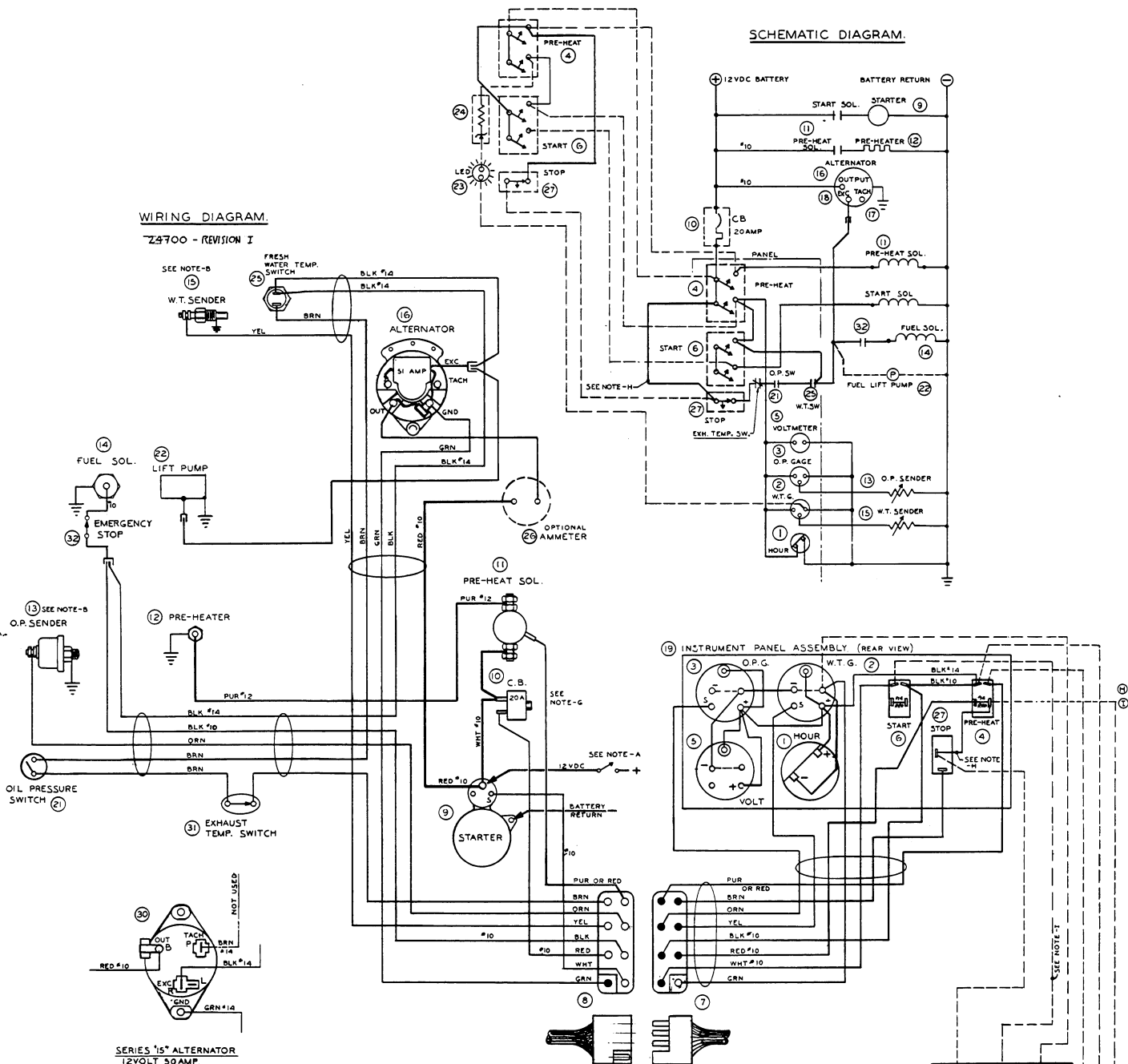

## SCHEMATIC DIAGRAM.

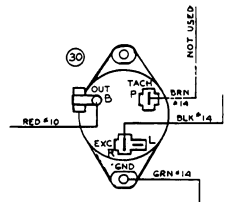
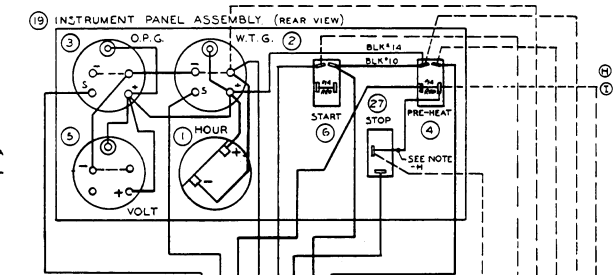
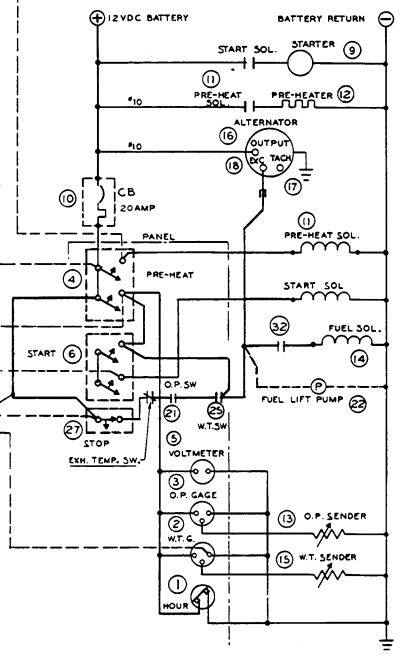

SERIES '15' ALTERNATOR  
12VOLT 30AMP.

**GENERATOR OPERATION.**  
**PREHEAT:** DEPRESS PREHEAT SWITCH FROM 15 TO 60 SECONDS AS REQUIRED.  
**START:** DEPRESS BOTH PREHEAT AND START SWITCHES (PREHEAT ALSO OVERRIDES LOW OIL PRESSURE SHUTDOWN CIRCUIT).  
**WHEN GENERATOR STARTS, RELEASE START SWITCH ONLY. CONTINUE HOLDING PREHEAT SWITCH FOR A FEW SECONDS UNTIL OIL PRESSURE REACHES 20PSI).**  
**STOP:** DEPRESS STOP SWITCH UNTIL THE GENERATOR STOPS COMPLETELY.

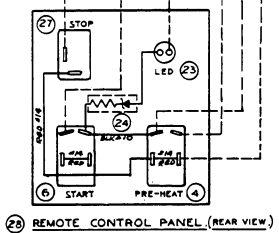

28 REMOTE CONTROL PANEL (REAR VIEW)

WESTERBEKE 3KW - ELECTRICAL SYSTEM

REF	PN	NAME	REMARKS	QUAN
1	12892	METER	HOUR	1
2	11545	GAUGE	WATER TEMPERATURE	1
3	24133	GAUGE	OIL PRESSURE 0-100 PSI	1
4	24732	SWITCH	PRE-HEAT	1
5	23090	VOLTMETER	12 VDC NEG GROUND	1
6	24732	SWITCH	START	1
7	30147	CABLE	PANEL	1
8	32539	HARNESS	ENGINE	1
9	32940	MOTOR	STARTER	1
10	24683	BREAKER	CIRCUIT-20 AMP	1
11	24639	SOLENOID	PRE-HEAT	1
12- 1	33204	GLOWPLUG		2
12- 2	33205	WIRE	GLOWPLUG CONNECTING	1
13	24132	SENDER	OIL PRESSURE 0-100 PSI	1
14	23041	SOLENOID	FUEL SHUT-OFF	1
15	23571	SENDER	WATER TEMPERATURE	1
19- 1	32340	PANEL	COMPLETE	1
19- 2	24999	TEMPLATE	INSTRUMENT PANEL	1
21	33348	SWITCH	OIL PRESSURE-NO	1
22	24831	PUMP	ELECTRIC FUEL LIFT	1
23	32975	LED	REMOTE CONTROL PANEL	1
24- 1	13723	RESISTOR	REMOTE CONTROL PANEL	1
24- 2	13724	DIODE	REMOTE CONTROL PANEL	1
25	30996	SWITCH	WATER TEMPERATURE-NC	1
26	11581	AMMETER	0-60-0 OPTIONAL	1
27	24731	SWITCH	STOP	1
28- 1	24943	PANEL	REMOTE CONTROL-OPTIONAL	1
28- 2	32122	PLATE	REMOTE CONTROL PANEL	1
28- 3	32123	TEMPLATE	REMOTE CONTROL PANEL	1
29	24968	DECAL	GENERATOR OPERATING INSTRUCTIONS	1
30	32939	ALTERNATOR	35AMP-12VDC-NEG GROUND WITH REGULATOR	1
31- 1	32923	SWITCH	EXHAUST TEMPERATURE	1
31- 2	33213	TUBING	TEFLON-WIRE PROTECTION-INCHES REQUIRED	18
32- 1	33259	SWITCH	EMERGENCY STOP	1
32- 2	33258	BOLT	EMERGENCY STOP SWITCH	1
32- 3	33251	LABEL	EMERGENCY STOP SWITCH	1
50	24700	DIAGRAM	WIRING	1
51	33883	LABEL	AC OUTPUT CONNECTION	1
52	30762	DIAGRAM	AC OUTPUT CONNECTION	1

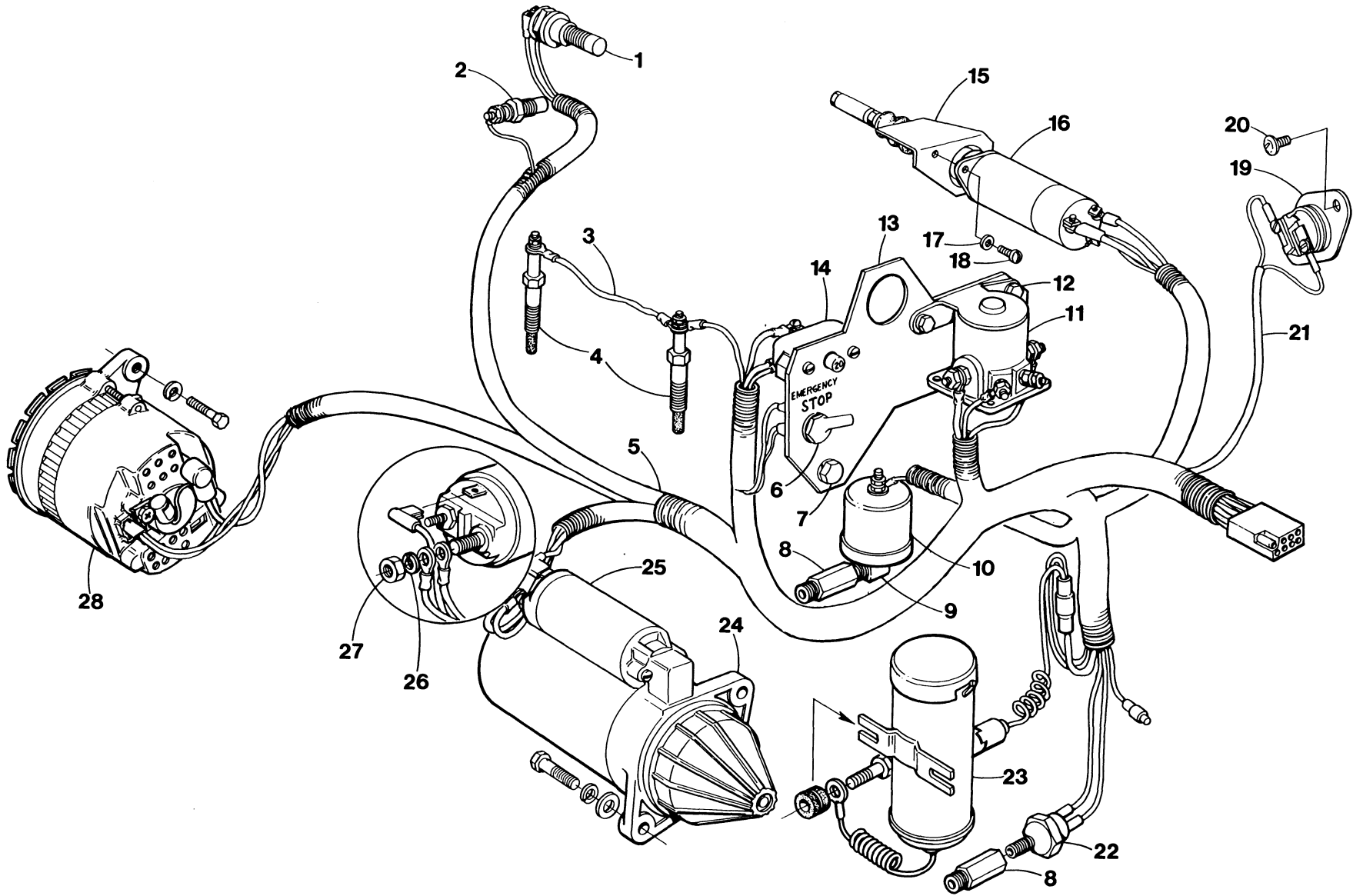

WESTERBEKE 3KW - GENERATOR HARNESS

WESTERBEKE 3KW - GENERATOR HARNESS

REF	PN	NAME	REMARKS	QUAN
1	30096	SWITCH	WATER TEMPERATURE-SAFETY	1
2	23571	SENDER	WATER TEMPERATURE	1
3	33205	WIRE	GLOWPLUG CONNECTING	1
4	33204	GLOWPLUG	12VDC	2
5	32539	HARNESS		1
6- 1	33259	SWITCH	EMERGENCY STOP	1
6- 2	33258	BOOT	EMERGENCY STOP SWITCH	1
6- 3	33251	LABEL	EMERGENCY STOP SWITCH	1
7- 1	17196	CAPSCREW	M8 X 25 DIN 933	1
7- 2	31786	LOCKWASHER	M8 DIN 127	1
8	24844	ADAPTER		2
9	11984	ELBOW	1/8NPT STREET 90	1
10	24132	SENDER	OIL PRESSURE	1
11	24639	SOLENOID	PRE-HEAT 12VDC	1
12- 1	31501	CAPSCREW	1/4NC X 1/2	2
12- 2	31752	LOCKWASHER	1/4	2
12- 3	31750	NUT	1/4NC	2
13	32458	BRACKET	CIRCUIT BREAKER AND SOLENOID	1
14- 1	24683	BREAKER	CIRCUIT 20AMP	1
14- 2		SCREW	8-32 X 7/8	2
14- 3		LOCKWASHER	8	2
15	32945	BRACKET	FUEL SHUT-OFF SOLENOID	1
16	23641	SOLENOID	FUEL SHUT-OFF 12VDC	1
17		LOCKWASHER	10	2
18		SCREW	10-32 X 5/8	2
19	32923	SWITCH	EXHAUST TEMPERATURE-SAFETY	1
20	33627	SCREW	8-32 X 1/4 WASHER HEAD	2
21	33213	TUBING	TEFLON-PROTECT WIRE-INCHES REQUIRED	18
22	33348	SWITCH	OIL PRESSURE-SAFETY	1
23	24831	PUMP	FUEL LIFT 12VDC	1
24	32940	MOTOR	STARTER 12VDC	1
25	30245	SOLENOID	STARTER 12VDC	1
26	31786	LOCKWASHER	M8 DIN 127	1
27	18242	NUT	M8 DIN 934	1
28	32939	ALTERNATOR	35 AMP 12VDC	1

WESTERBEKE 3KW - GENERATOR CONTROL PANEL

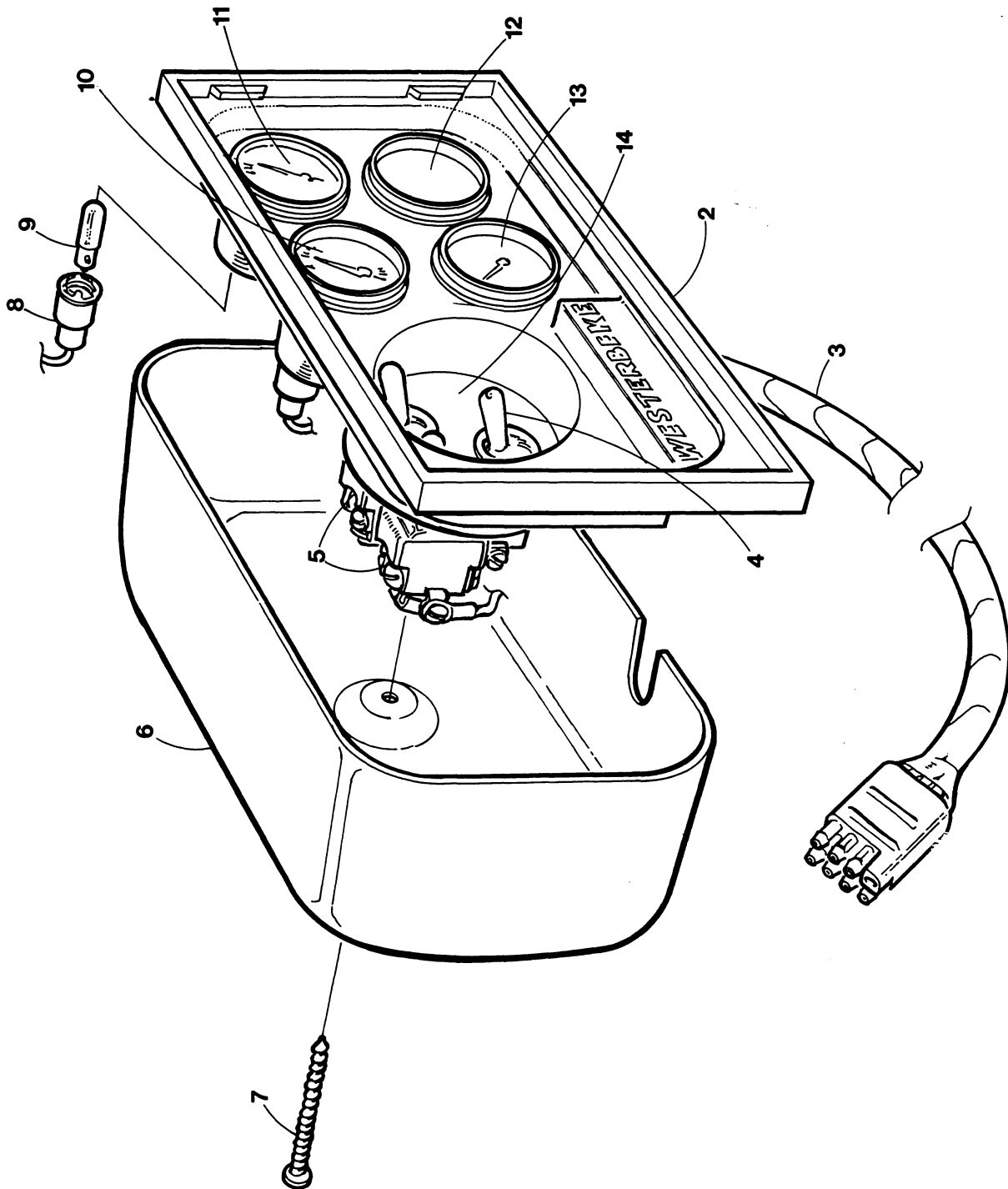

WESTERBEKE 3KW - GENERATOR CONTROL PANEL

REF	PN	NAME	REMARKS	QUAN
1	32340	PANEL	INSTRUMENT ASSEMBLY	1
2	33867	PANEL	FACEPLATE	1
3	30147	CABLE	PANEL TO ENGINE	1
4	24731	SWITCH	STOP	1
5	24732	SWITCH	START-PREHEAT	2
6	30119	COVER	PANEL REAR	1
7	30913	SCREW	COVER	1
8	24946	HOLDER	LAMP	3
9	24947	LAMP	INSTRUMENT METERS	3
10	11545	METER	WATER TEMPERATURE	1
11	24133	METER	OIL PRESSURE 0-100 PSI	1
12	23090	VOLTMETER	12 VDC NEG GRDUNG	1
13	12892	METER	HOUR	1
14	32449	LABEL	SWITCH IDENTIFICATION	1
15	30760	CABLE	15 FOOT PANEL EXTENSION	1
16	24968	DECAL	GENERATOR OPERATING INSTRUCTIONS	1



WESTERBEKE 3KW - FUEL SOLENOID ASSEMBLY

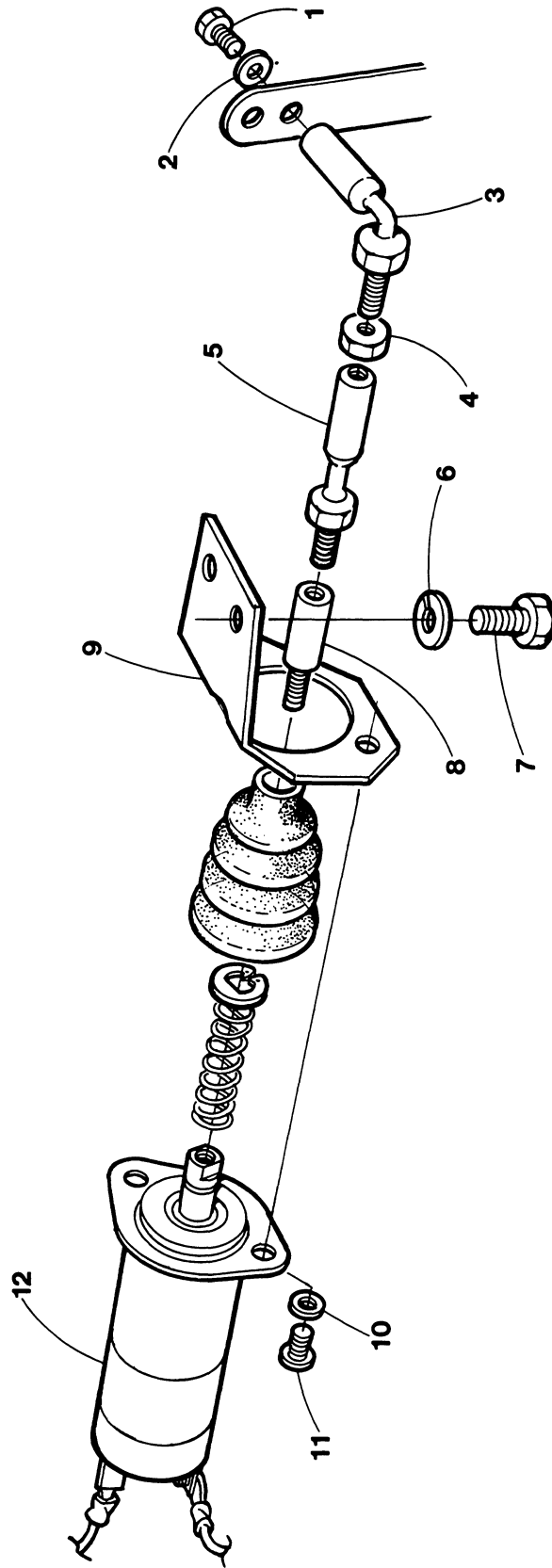

WESTERBEKE 3KW - FUEL SOLENOID ASSEMBLY

REF	PN	NAME	REMARKS	QUAN
1	31526	CAPSCREW	1/4NF X 1/2	1
2	31752	LOCKWASHER	1/4	1
3	15232	BALL JOINT	90 DEGREE	1
4	15534	NUT	1/4NF JAM	1
5	15225	BALL JOINT		1
6	31752	LOCKWASHER	1/4	2
7	31502	CAPSCREW	1/4NC X 5/8	2
8	30053	STANDOFF	1/4NF X 7/8	1
9	32945	BRACKET	FUEL SHUT-OFF SOLENOID	1
10		LOCKWASHER	10	2
11		SCREW	10-32 X 1/2	2
12	23041	SOLENOID	FUEL SHUT-OFF	1

WESTERBEKE 3KW - GENERATOR 2 WIRE 60 HERTZ

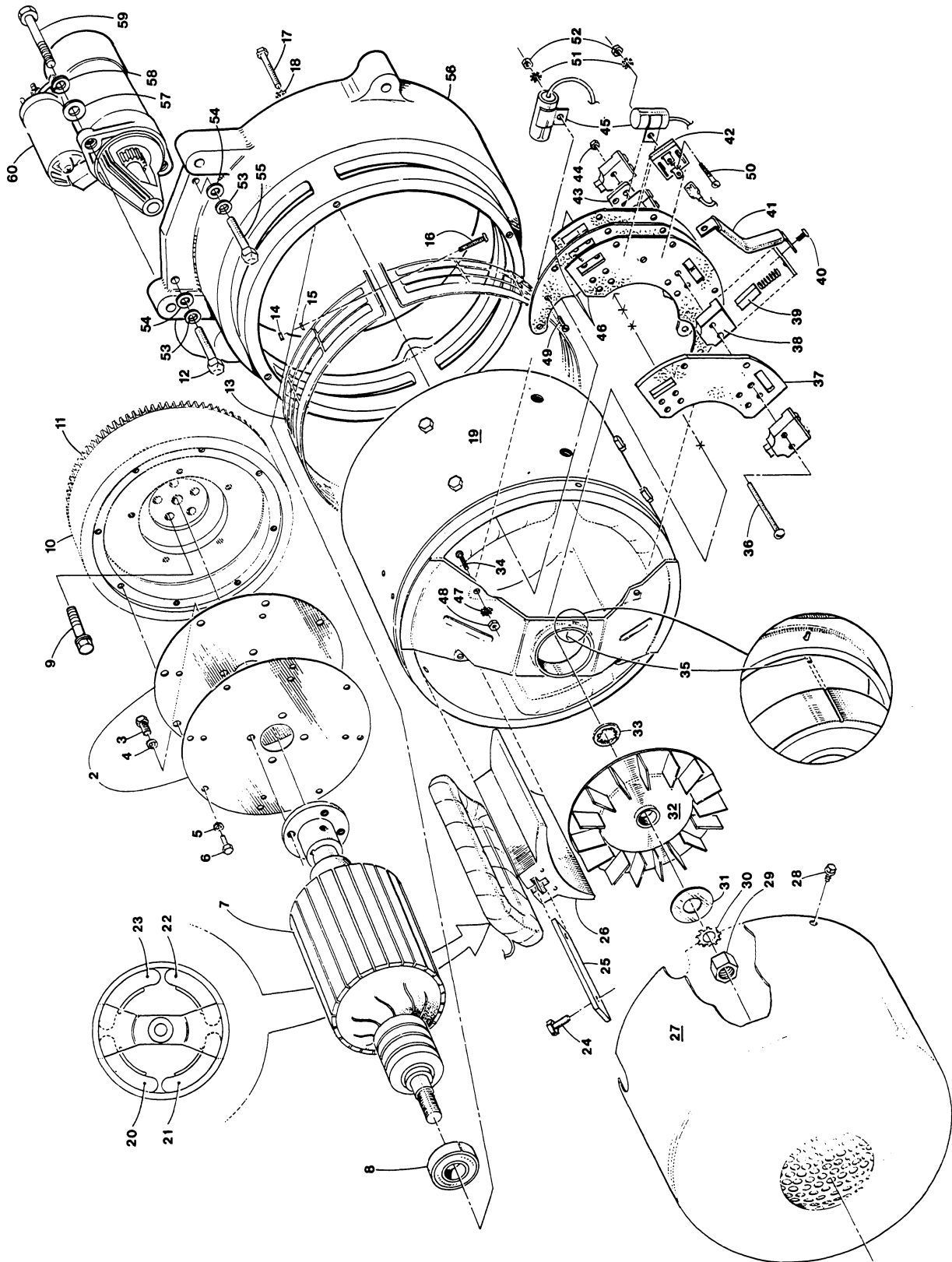

WESTERBEKE 3KW - GENERATOR 2 WIRE 60 HERTZ

REF	PN	NAME	REMARKS	QUAN
1	30860	GENERATOR	3KW-60HZ-115VAC-2 WIRE	1
2	30115	PLATE	DRIVE DISC	2
3	31678	CAPSCREW	7/16NF X 3/4	4
4	31770	LOCKWASHER	7/16	4
5	31758	LOCKWASHER	5/16	8
6	31553	CAPSCREW	5/16NC X 3/4	8
7	30176	ARMATURE	60HZ	1
8	30822	BEARING		1
9	33279	BOLT	FLYWHEEL WITH FLANGE	4
10	32312	FLYWHEEL	WITH RING GEAR	1
11	32996	GEAR	RING	1
12	24954	CAPSCREW	M10X1.25X40 DIN 961	1
13	24788	GUARD		1
14		NUT	10-32	1
15		LOCKWASHER	10	1
16		SCREW	10-32 X 1	1
17	31561	CAPSCREW	5/16NC X 2-1/2	4
18	31758	LOCKWASHER	5/16	4
19	31075	HOUSING	FIELD COIL	1
20	30835	COIL	FIELD	1
21	30836	COIL	FIELD	1
22	30837	COIL	FIELD	1
23	30838	COIL	FIELD	1
24	31607	CAPSCREW	3/8NC X 1-1/2	8
25	31064	RETAINER	POLE SHOE	4
26	30802	SHOE	POLE	4
27	30813	COVER	GENERATOR END	1
28		SCREW	10-24 X 3/8 HEX HEAD THREAD CUTTING	2
29	30841	NUT	1/2NF JAM LOCKING	1
30		LOCKWASHER	1/2-EXTERNAL TOOTH	1
31	30798	WASHER	1/2 FLAT	1
32	30799	FAN		1
33	30805	LOCKWASHER		1
34		SCREW	10-24 X 3/4	4
35	30823	PIN	BEARING LOCK	1
36		SCREW	8-32 X 1-1/2 RH	6
38	30800	HOLDER	BRUSH	6
39	30814	BRUSH		6
40		SCREW	8-32 X 5/16	12
41	33395	STRAP	COPPER	2
42	30809	RECTIFIER		1
44		NUT	8-32	6
45	30806	CAPACITOR		1
46	31070	PLATE	BRUSH MOUNTING	2
47		LOCKWASHER	INTERNAL TOOTH 10	4
48		NUT	10-24	4
49		SCREW	8-32 X 1/4	1

WESTERBEKE 3KW - GENERATOR 2 WIRE 60 HERTZ

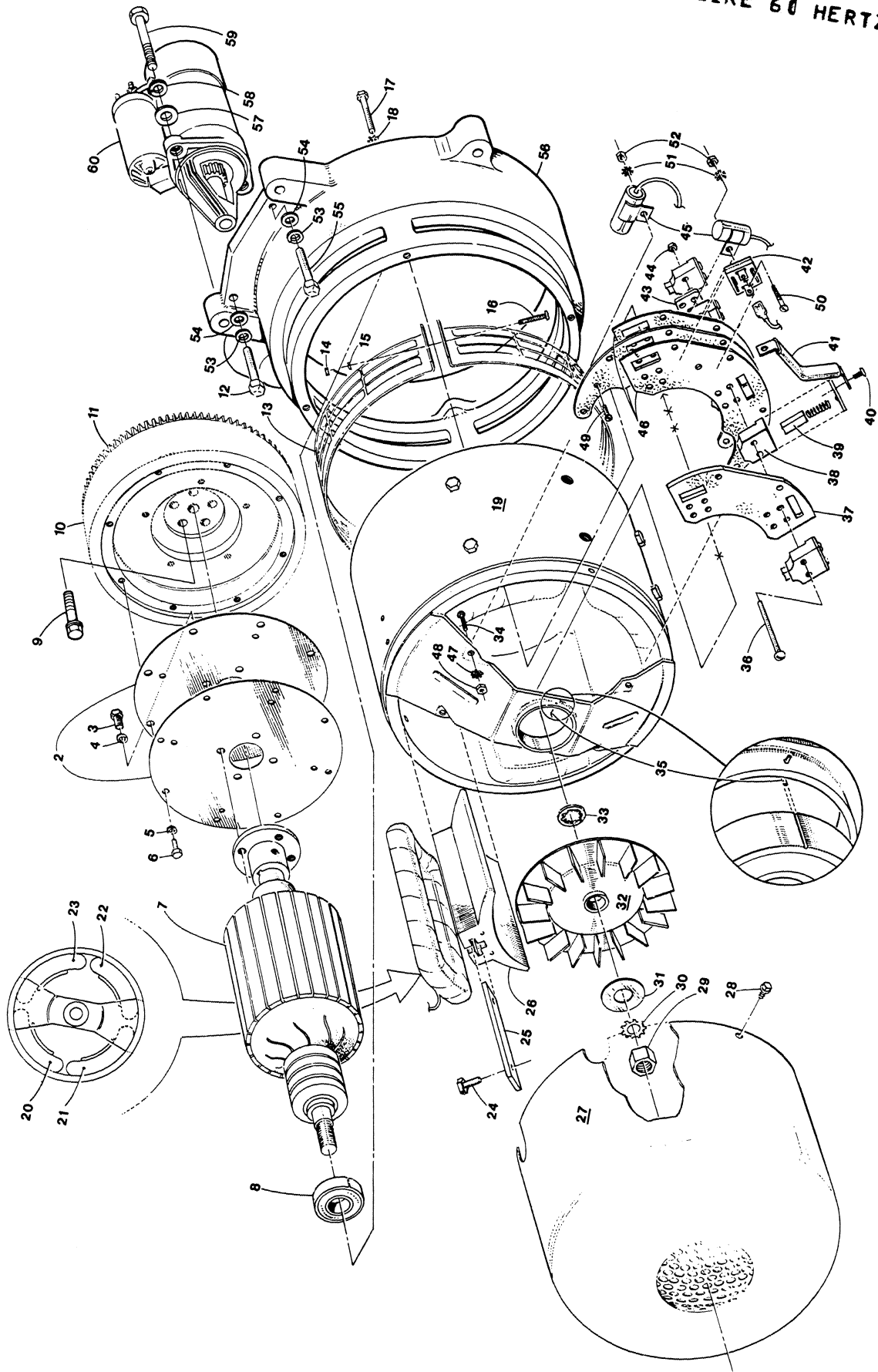

WESTERBEKE 3KW - GENERATOR 2 WIRE 60 HERTZ

REF	PN	NAME	REMARKS	QUAN
50		SCREW	8-32 X 7/8	1
51		LOCKWASHER	8-EXTERNAL TOOTH	2
52		NUT	8-32	2
53	19262	LOCKWASHER	M10 DIN 127	6
54	31789	WASHER	FLAT M10 DIN 125	6
55- 1	24953	CAPSCREW	M10X1.25X35 DIN 961	4
55- 2	24955	CAPSCREW	M10X1.25X45 DIN 961 BATTERY GROUND	1
55- 3	24950	NUT	M10X1.25 DIN 934 BATTERY GROUND	1
56	32332	HOUSING	FLYWHEEL	1
57	31787	WASHER	FLAT M8 DIN 125	2
58	31786	LOCKWASHER	M8 DIN 127	2
59	13630	CAPSCREW	M8X25 DIN 933	2
60	32940	MOTOR	STARTER	1

WESTERBEKE 3KW - GENERATOR 3 WIRE 60 HERTZ

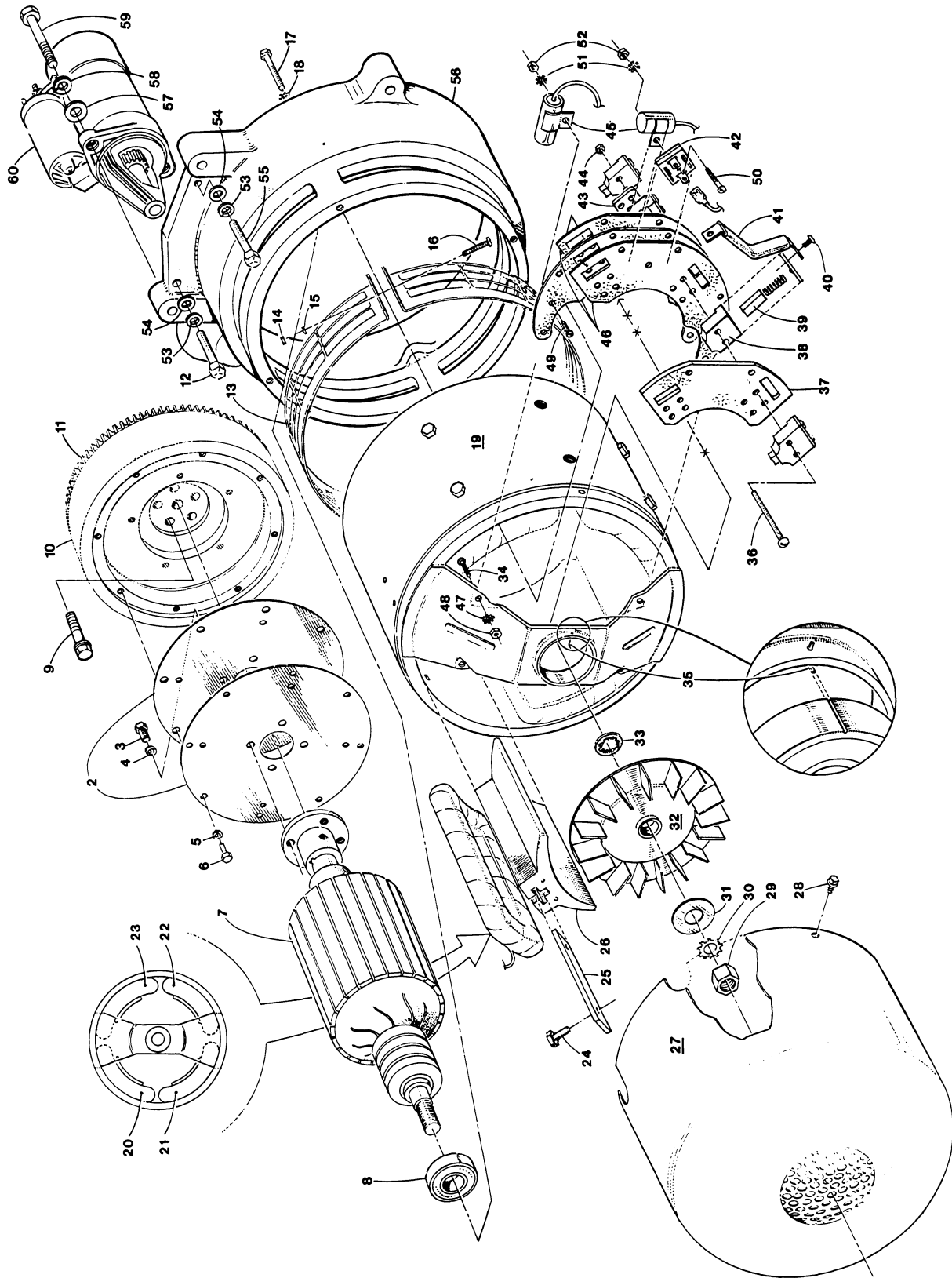

WESTERBEKE 3KW - GENERATOR 3 WIRE 60 HERTZ

REF	PN	NAME	REMARKS	QUAN
1	24759	GENERATOR	3KW-60HZ-115/230VAC-3 WIRE	1
2	30115	PLATE	DRIVE DISC	2
3	31678	CAPSCREW	7/16NF X 3/4	4
4	31770	LOCKWASHER	7/16	4
5	31758	LOCKWASHER	5/16	8
6	31553	CAPSCREW	5/16NC X 3/4	8
7	30826	ARMATURE	60HZ	1
8	30822	BEARING		1
9	33279	EOLT	FLYWHEEL WITH FLANGE	4
10	32312	FLYWHEEL	WITH RING GEAR	1
11	32996	GEAR	RING	1
12	24954	CAPSCREW	M10X1.25X40 DIN 961	1
13	24788	GUARD		1
14		NUT	10-32	1
15		LOCKWASHER	10	1
16		SCREW	10-32 X 1	1
17	31561	CAPSCREW	5/16NC X 2-1/2	4
18	31758	LOCKWASHER	5/16	4
19	30834	HOUSING	WITH FIELD COIL & BRUSH ASSY	1
20	30835	COIL	FIELD	1
21	30836	COIL	FIELD	1
22	30837	COIL	FIELD	1
23	30838	COIL	FIELD	1
24	31607	CAPSCREW	3/8NC X 1-1/2	8
25	31064	RETAINER	POLE SHOE	4
26	30802	SHOE	POLE	4
27	30813	COVER	GENERATOR END	1
28		SCREW	10-24 X 3/8 HEX HEAD THREAD CUTTING	2
29	30841	NUT	1/2NF JAM LOCKING	1
30		LOCKWASHER	1/2-EXTERNAL TOOTH	1
31	30798	WASHER	1/2 FLAT	1
32	30799	FAN		1
33	30805	LOCKWASHER		1
34		SCREW	10-24 X 3/4	4
35	30823	PIN	BEARING LOCK	1
36		SCREW	8-32 X 2 RH	4
38	30800	HOLDER	BRUSH	6
39	30814	BRUSH		6
40		SCREW	8-32 X 5/16	12
41	33395	STRAP	COPPER	2
42	30809	RECTIFIER		1
44		NUT	8-32	4
45	30806	CAPACITOR		2
46	30839	BRUSH ASSY	REF 36-52	1



WESTERBEKE 3KW - GENERATOR 3 WIRE 60 HERTZ

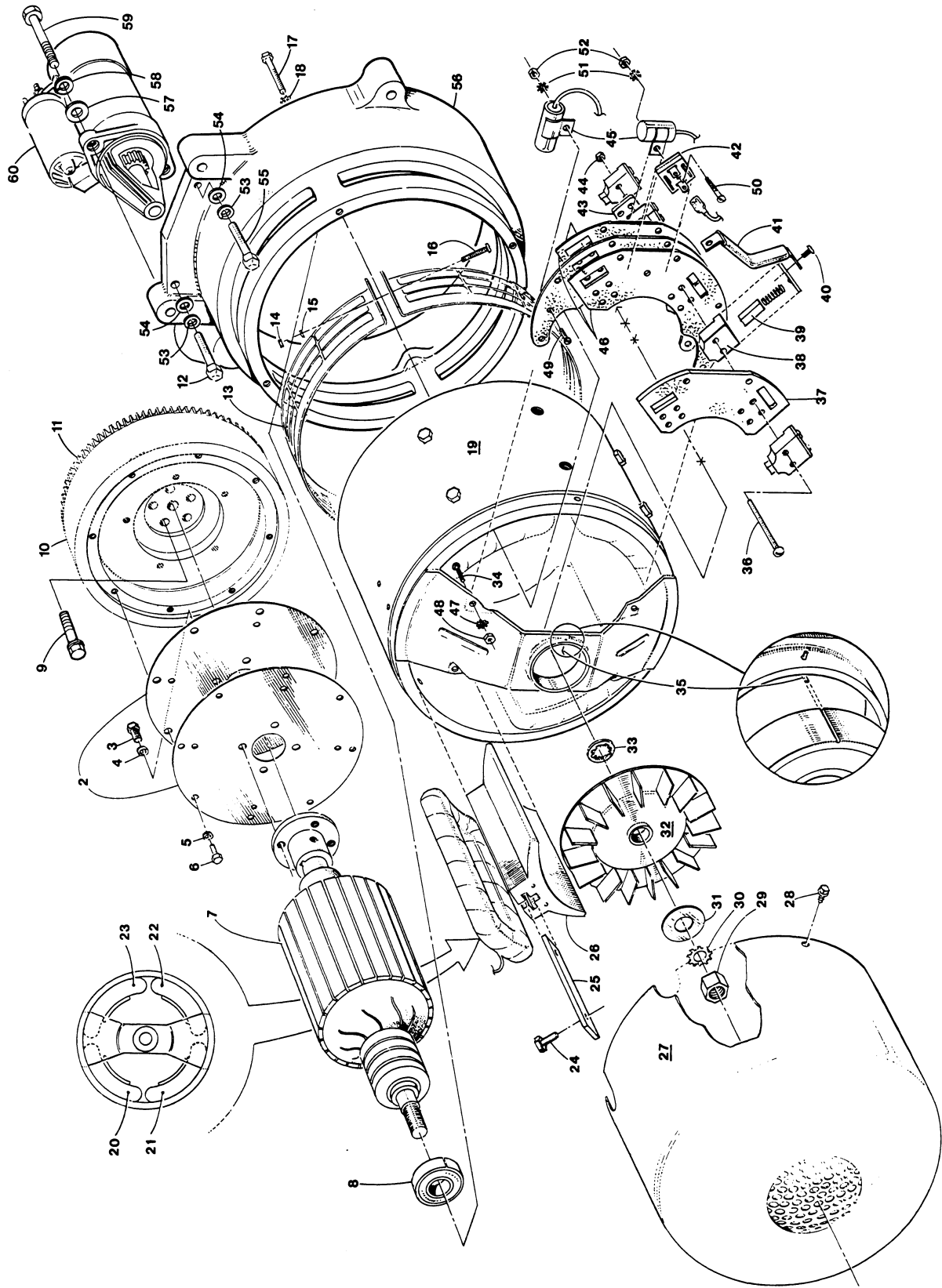

WESTERBEKE 3KW - GENERATOR 3 WIRE 60 HERTZ

REF	PN	NAME	REMARKS	QUAN
53	19262	LOCKWASHER	M10 DIN 127	6
54	31789	WASHER	FLAT M10 DIN 125	6
55- 1	24953	CAPSCREW	M10X1.25X35 DIN 961	4
55- 2	24955	CAPSCREW	M10X1.25X45 DIN 961 BATTERY GROUND	1
55- 3	24950	NUT	M10X1.25 DIN 934 BATTERY GROND	1
56	32332	HOUSING	FLYWHEEL	1
57	31787	WASHER	FLAT M8 DIN 125	2
58	31786	LOCKWASHER	M8 DIN 127	2
59	13630	CAPSCREW	M8X25 DIN 933	2
60	32940	MOTOR	STARTER	1

# WESTERBEKE 3KW - BELT GUARD

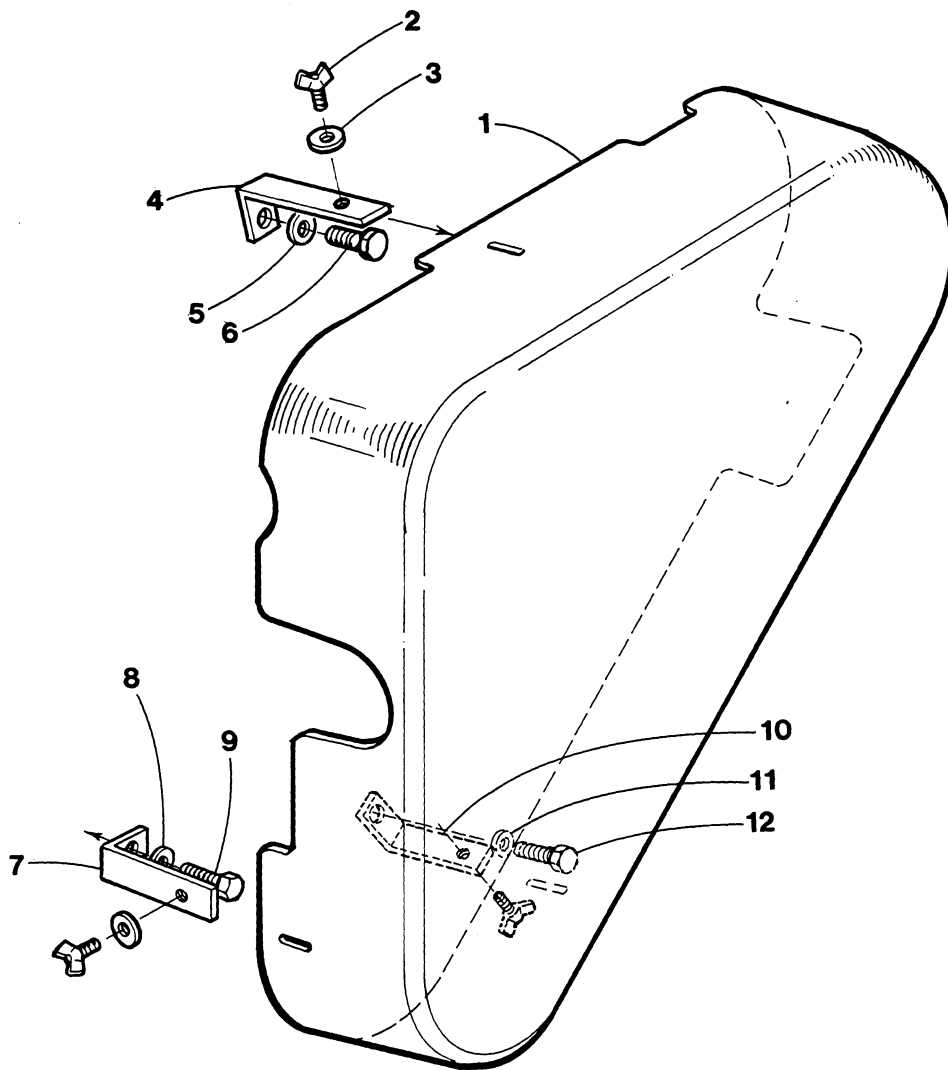

WESTERBEKE 3KW - BELT GUARD

REF	PN	NAME	REMARKS	QUAN
1	33054	GUARD	BELT	1
2	33228	SCREW	WING 10-32 X 1/2	3
3- 1		LOCKWASHER	10	3
3- 2	33372	WASHER	FLAT	3
4	33063	BRACKET	TOP	1
5	31786	LOCKWASHER	M8 DIN 127	1
6	20650	CAPSCREW	M8 X 18 DIN	1
7	33240	BRACKET		1
8	31783	LOCKWASHER	M6 DIN 127	1
9	33351	CAPSCREW	M6 X 60 DIN 931	1
10	33239	BRACKET		1
11	31783	LOCKWASHER	M6 DIN 127	1
12	20620	CAPSCREW	M6 X 25 DIN	1

WESTERBEKE 10TWO - MISCELLANECUS

REF	PN	NAME	REMARKS	QUAN
1	33077	KIT A	SPARE PARTS	1
2	33078	KIT B	SPARE PARTS	1
3	33075	GASKET SET	UPPER	1
4	33076	GASKET SET	COMPLETE	1
5	33079	KIT	FUEL HARDWARE	1
6	32974	FILTER	WATER SEPARATOR	1
7	32550	MUFFLER	HYDRO-HUSH FIBERGLASS	1
8	12169	LINE	FLEXIBLE EXHAUST-STAINLESS-1.5 X 12 LG	1
9	15010	STRAINER	SEA WATER	1
10	13758	PAINT	REC-AEROSOL SPRAY CAN	1
11	20654	SPLITTER	ALTERNATOR OUTPUT	1
12	30760	HARNES	15 FOOT PANEL EXTENSION	1
13	32149	FILTER	REMOTE LUBE OIL-KIT	1
14	32008	SWITCH	GENERATOR SHIP-SHORE	1
15	33105	MANUAL	OPERATORS	1
16	33403	MANUAL	TECHNICAL	1
17	33404	MANUAL	PARTS LIST	1
18- 1	33772	MUFFLER	HYDRO HUSH B	1
18- 2	33340	CONNECTOR	HOSE STRAIGHT	1
18- 3	33341	CONNECTOR	HOSE 45 DEGREE	1
18- 4	33342	CONNECTOR	HOSE 90 DEGREE	1
18- 5	33943	KIT	HOSE COUPLING AND CLAMPS	1