

6 kW

60 Hz / 1800 RPM

5 kW

50 Hz / 1500 RPM

Service Side

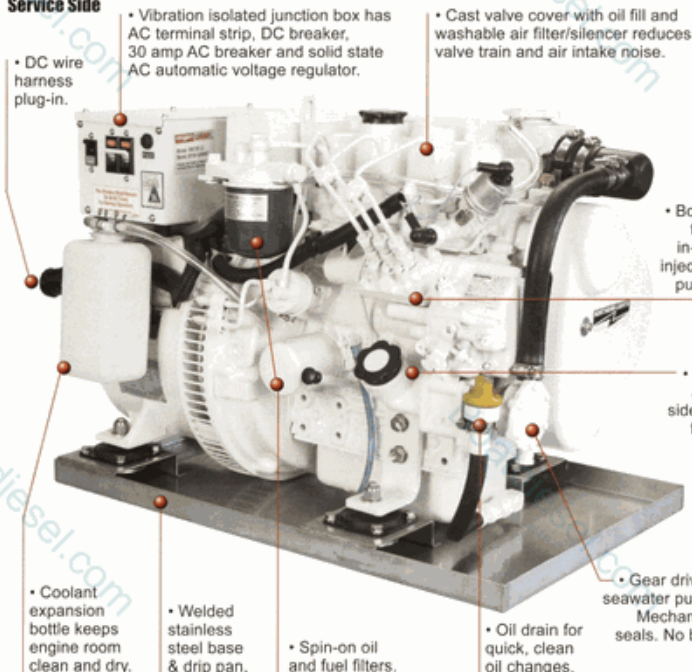

1800 RPM VS 3600 RPM

Small and light weight are important and the M643L is both. But neither is more important than reliability and long life. That is why the M673L runs at 1800 RPM (1500 rpm for 50Hz) instead of 3600 revvvs.

Consider that during only 2000 hours of operation the 1800 rpm M673L will turn 216 million fewer revolutions than a 3600 rpm set. Its pistons will travel 38,522 fewer miles. Its cylinders will withstand 108 million fewer detonations. Which engine do you think will give more years of reliable service? We couldn't agree more.

Smooth and Quiet

The M673L has a balanced Luger three cylinder diesel instead of a rough two banger. Four platform isolation mounts reduce vibration transmission even more. An air intake silencer/filter, cast valve cover and cast iron, wet exhaust system muffle internal engine noise.

For maximum comfort afloat add a sound enclosure. Only 32.5 inches long, it fits your boat and it has powder-coated, aluminum panels with trigger latches to make routine maintenance, well, routine.

Clean AVR Power Means More Power Out.

The generator's automatic voltage regulator is powered by an auxiliary AC stator winding that isolates it from the main windings. The AVR always has clean power to provide excitation for faster load response and better motor starting. Your air conditioner and other motor driven equipment will love being matched with the 673.

Safe For You And The Environment.

A 30 amp AC circuit breaker in the junction box protects your wiring. Safety shutdowns for low oil pressure, high coolant temperature and high exhaust temperature protect your engine.

The M673L meets current emission standards. You, your moorage neighbors and the environment will all benefit.

The M673L: Everything you want.

1800 rpm reliability, low emissions, quiet operation and strong motor starting. Good things do come in small packages.

Non-Service Side

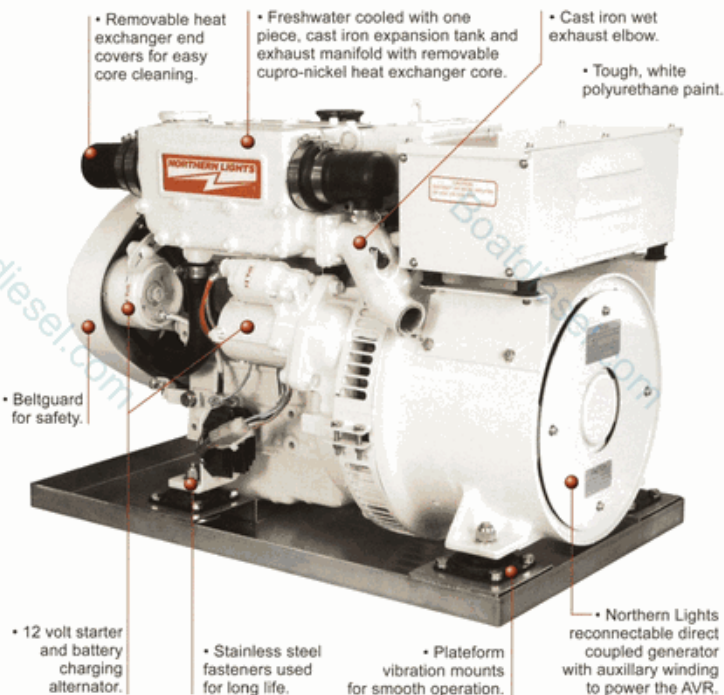

M673L Specifications and Dimensions

M673L - 6 kW/5 kW

AC Output¹

6 kW 60 Hz, 1800 RPM, 1 Ph, 1.0 PF,
120-240 V/25 A, 120 V/50A

5 kW 50 Hz, 1500 RPM, 1 Ph, 1.0 PF,
220 V/22.7 A

Voltage regulation ±5%

Lugger L673L Engine

Type Vertical inline 3 cylinder diesel

Displacement 46.4 in³ (0.761 ltr)

Bore/Stroke 2.64/2.83 in (67/72 mm)

HP @ RPM 10.1/1800 8.4/1500

Approx. fuel use

1800 RPM @ full load² 0.59 gph (2.2 lph)

1800 RPM @ half load² 0.32 gph (1.2 lph)

1500 RPM @ full load² 0.50 gph (1.9 lph)

1500 RPM @ half load² 0.28 gph (1.1 lph)

Installation Data & Weight

Wet exhaust elbow 1.5 inch (38 mm) OD

Raw water inlet 3/4 inch (19 mm) OD

Fuel inlet and return 5/16 inch ID Hose

Approximate dry weight 362 lbs (164 kg)

1. Based on SAE J1995 and ISO 3046. 2. Actual fuel consumption will vary depending on operating conditions.

M673L Dimensional Drawing

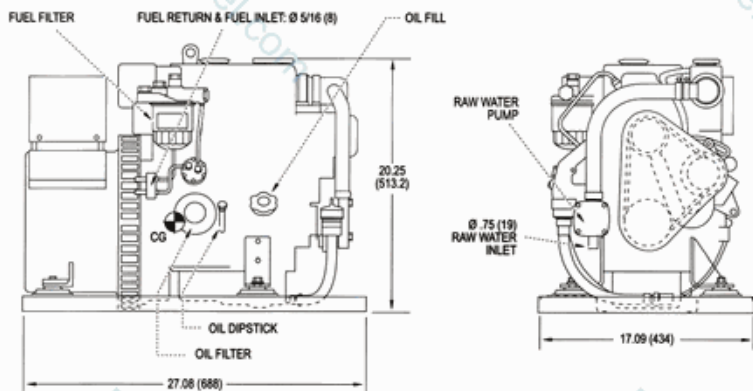

Overall Dimensions L x W x H: 27.08 x 17.09 x 20.25 inch (688 x 434 x 513.2)

Dimensions given in inches (mm). Dimensions subject to change without notice.
Contact dealer or visit www.northern-lights.com for most current installation drawings.

M673L Features and Benefits

Engine Block

- Four cycle, 3 cylinder, liquid cooled, naturally aspirated, overhead valve diesel.
- Swirl combustion chambers improve fuel efficiency and reduce smoke.
- Glow plugs for quick cold starting.

Cooling System

- Freshwater cooling with siphon break.
- Heat exchanger or keel cooled.
- One-piece heat exchanger, expansion tank and liquid cooled exhaust manifold. Fewer troublesome hoses and gaskets. Cast iron to resist corrosion and electrolysis.
- Heat exchanger cooling is standard. Cupronickel, tube-type heat exchanger has removable ends for easy cleaning. Rubber impeller seawater pump of bronze and stainless steel is gear driven; no belt.

Fuel System

- Fuel system is self-venting.
- Injection pump with 5% mechanical governor for close AC frequency control.
- Pintle injectors with replaceable tips.
- Mechanical lift pump with hand primer. No electric pump to fail.
- Large spin-on fuel filter.
- Steel fuel lines.
- Stop solenoid controls the fuel rack, not throttle, to eliminate speed variance and linkage problems.

Intake and Exhaust

- Meets US EPA emission requirements at date of manufacture.
- Washable air cleaner in cast intake manifold reduces intake noise.
- Cast iron, wet exhaust elbow for safety.

Lubrication System

- Full flow, spin-on oil filter with bypass.
- 3.1 qt (3 ltr) oil capacity for better lubrication and 200 hour oil change intervals.
- Oil drain for quick, clean oil changes.
- Closed crankcase vent system traps oil vapor and keeps engine room clean.

DC Electrical System

- DC system uses reliable relays instead of unrepairable printed circuit board.
- 12 volt starter motor and battery charging alternator with regulator and belt guard.
- Standard panel: Remote mount S-1B has hour meter, stop-start switch with run light and preheat switch.
- Expandable to six panels up to 110 feet from the set.
- 20 foot (6 m) plug-in panel harness lets you mount your panel anywhere onboard. Better than inaccessible unit mount panels that are prone to vibration problems.
- Low oil pressure, high coolant temperature and high exhaust temperature safety shutdowns standard.



AC Generator

- Northern Lights, direct coupled, 4 pole, revolving field, 4 lead reconnectable generator with Class "H" insulation and prelubricated bearing. Conservative heat rise rating: 95°C/50°C ambient.
- External automatic voltage regulator gives you ±5% voltage regulation. AVR powered by dedicated AC winding for improved motor starting. AVR circuit breaker.

- 30 amp mainline circuit breaker protects generator from AC overloads and shorts.

Special Equipment

- Stainless steel base frame with drip pan. Easy to mount. Keeps vessel clean.
- Four platform mounts isolate vibration.
- White, long-life polyurethane paint.
- Operator's and parts manuals standard.

Classification Standards

- Contact factory for details.



Optional Equipment

- DC gauge control panels.
- AC and DC control panels.
- Wire harness extensions and "Y" harness.
- Dry exhaust elbow.
- Dry exhaust muffler.
- 1.5 inch wet exhaust muffler.
- Exhaust / water separator.
- Keel cooling configuration.
- Onboard parts kits.
- Fuel filter-water separators.
- Shorepower switches.
- Sound enclosure has powder coated marine aluminum panels lined with sound barrier foam to dampen noise. Trigger latches allow easy service access.



LxWxH: 32.53 x 21.2 x 21.73 in
(826.3 x 538.4 x 552 mm)
Weight: 55 lbs (24.9 kg)

Dealer

4420 14th Ave. NW., Seattle WA 98107

Tel: (206) 789-3880 • 1-800-762-0165

Fax: (206) 782-5455

Information and dimensions subject to change without notice.

© 2004 All rights reserved. Litho USA. L680 9/04

NORTHERN LIGHTS

www.northern-lights.com