

For your convenience, Diesel Specialists is providing access to this Northern Lights Parts Catalog to assist you with purchasing the correct parts for your generator or engine.

Any of the parts listed in this catalog are available for purchase from the Northern Lights Generator Parts website.

Use the PDF search function to search the catalog: press CTRL + F and the search box will appear.

Once you have located the part number in the catalog, return to the Northern Lights Generator Parts website and type the part number in the Store Search Box. Then, add the item to your shopping cart to complete your purchase.

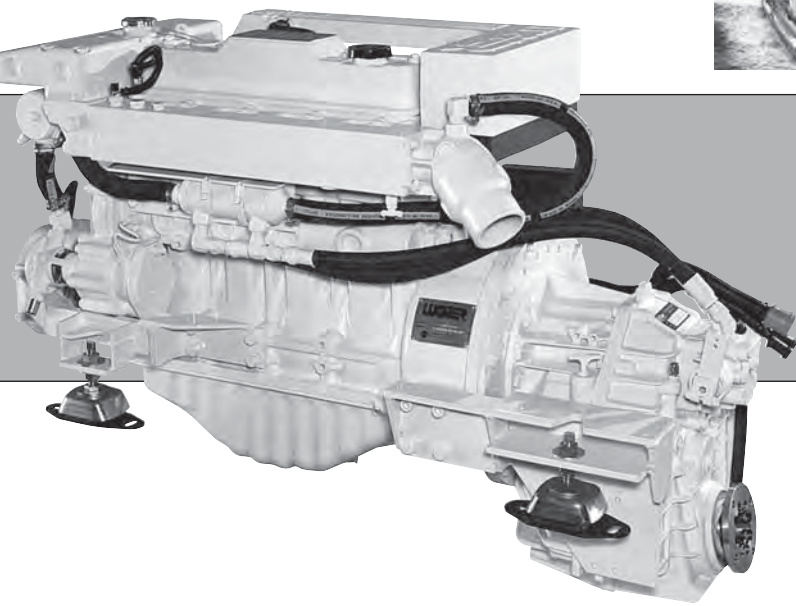

P984

For Models: M984K, ML984, L984,
M30C, M984W and M33CW

OPERATOR'S MANUAL

Marine Generators | Marine Diesel Engines | Land-Based Generators



LUGGER





— CALIFORNIA —
Proposition 65 Warning:

Diesel engine exhaust and some of its constituents are known to the State of California to cause cancer, birth defects, and other reproductive harm.

Northern Lights

4420 14th Avenue N.W.

Seattle, WA 98107

Tel: (206) 789-3880

Fax: (206) 782-5455

Copyright ©2005 Northern Lights, Inc.
All rights reserved. Northern Lights™, and
the Northern Lights logo are trademarks of
Northern Lights, Inc.

Printed in U.S.A.
PART NO.: P984 09/05



PARTS CATALOG

for Models M984K, ML984, L984, M30C, M33C, M984W, and M33CW

Please read thoroughly before attempting to use this manual:

Table of Contents	I
Model Designation & Serial Numbers	II
Reading a Parts Page	III

Table of Contents

GROUP 1 - ENGINE

Cylinder Block	0 - 1
Crankshaft, Pistons & Connecting Rods.....	2 - 5
Flywheel & Housing	6
Lubrication System.....	7 - 8
Timing Cover.....	9
Camshaft & Valve Train.....	10 - 13
Cylinder Head & Valve Cover.....	14 - 15
Oil Drain Kit.....	16

GROUP 2 - INTAKE & EXHAUST SYSTEM

Air Intake & Intake Noise Reduction.....	0 - 3
Intake Manifold.....	4
Air Inlet	5
Exhaust Manifold	6
Wet Exhaust Elbow.....	7
Dry Exhaust Elbow.....	8

GROUP 3 - COOLING

Expansion Tank & Thermostat Housing.....	1
Heat Exchanger & Mounting	2
Heat Exchanger Assembly	3
Coolant Pump	4
Keel Cooling Outlet.....	5
Raw Water Pump & Mounting	6
Raw Water Pump Detail	7

GROUP 4 - FUEL SYSTEM

Injectors & Lines	0 - 1
Injection Pump & Piping	2 - 3
Fuel Filter & Piping	4 - 5
Fuel System	6
Coast Guard Approved Fuel System	7
Fuel Feed Pump Assembly	8

GROUP 5 - ELECTRICAL SYSTEM

Engine.....	0 - 5
Dual Station Relay Board.....	6
Circuit Breaker & Relay Assembly.....	7
Stop Solenoid & Mounting	8
Alternator Mounting	9 - 10
Alternator	11 - 13
Starter	14
Control Panels.....	15 - 25
Belt Guard	26 - 30

GROUP 6 - GASKET SETS

Gasket Sets.....	1
------------------	---

GROUP 7 - GEAR AND ADAPTER SETS

Gear & Adapter.....	0 - 3
---------------------	-------

GROUP 8 - FRAME & MOUNTING

Base Frame Assemblies.....	0 - 3
Front Engine Mounts	4
Lifting Eye.....	5

GROUP 9 - ACCESSORIES & OPTIONAL EQUIPMENT

PTO Adapter.....	0 - 1
Electric Clutch	2
Oil Drain Kit.....	3
Low Oil Level Switch.....	4
Water Level Switch.....	5
Pre-Alarm Switches	6
Raw Water Flow Switch.....	7

Proprietary Information

This publication is the sole property of Alaska Diesel Electric, Inc.
It may not be reproduced in whole or part without the expressed written permission of Alaska Diesel Electric, Inc.
© Alaska Diesel Electric, Inc. 2005. All rights reserved. Litho U.S.A. Publication number: P984 09/05.

Model Designation

MODELS INCLUDED

This manual covers the operating instructions for

M984K, ML984, L984, M33C, M984W, and M33CW which use the 984 engine.

Model Numbers

Model numbers give the unit's application, block model, aspiration, and RPM:

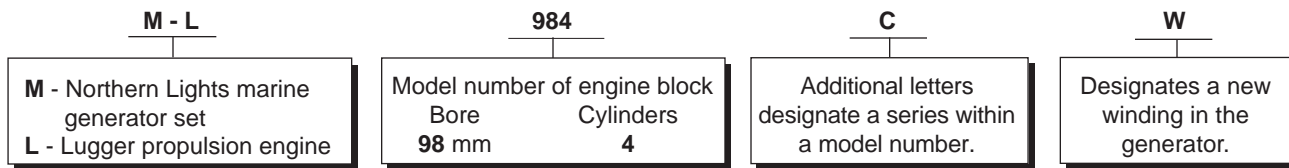

M984K = Northern Lights marine diesel generator set with a 984 engine and a PX-332K generator.

M33C = Northern Lights 33 kW commercial grade marine diesel generator set.

ML984 = Northern Lights marine diesel generator set with a 984 engine and a PSL generator.

M984W = Northern Lights marine diesel generator set with a 984 engine and a PX-332K2 generator.

L984 = Luger propulsion engine with a 984 engine.

M33CW = Northern Lights marine diesel generator set with a 984 engine and a PX-332K2 generator.

Serial Numbers

NORTHERN LIGHTS

Northern Lights generator sets with PSL generators have two data plates and two serial numbers. One serial number is for the generator end, and it is found on the Generator End Data Plate. **The other serial number, found with the Generator Set Data Plate, should be used when ordering parts for sets using PSL generators.** Units with PXX generators have just one plate. Serial numbers for Northern Lights units are eight digits in length (e.g. 1234-5678).

LUGGER

When ordering Luger parts, please refer to the serial number located on the flywheel housing.

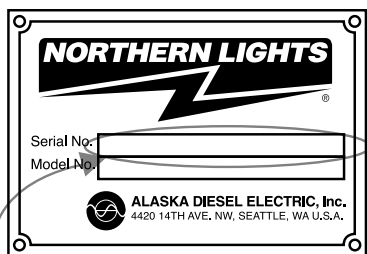

*Generator Set Serial Number
for units with PX K and PSL
generators*

*Generator End Serial Number
for units with PSL generators*

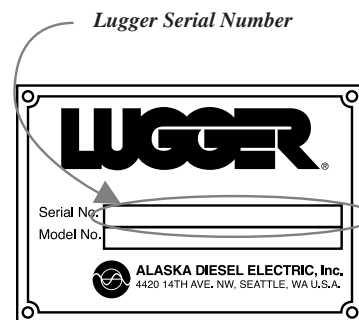
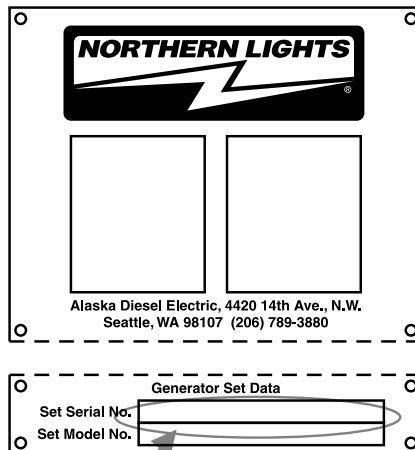

IMPORTANT:

Before selecting parts, be sure that you are choosing parts from the correct page.
Check the model designation at the page top.
Do not use this illustration for parts purchasing.

KEY	PART NUMBER	QTY.	DESCRIPTION	SERIALNUMBER
0	185046210	1	Alternator Assembly	-
1	185446219	1	Flywheel, complete	-
2	185446217	1	Plate, complete	-
3	185716200	1	Plate	-
4	185446218	1	Stator, complete	-
5	040126210	2	Bearing	-
6	020210010	1	Nut	-
7	027100010	1	Spring washer	-
8	026100010	1	Washer	-
9	185446220	1	Clamp	-
10	015140408	1	Screw	-
11	015140425	2	Screw	-
12	199236510	1	Collar	-

REFERENCES:

1. Grouping section title.
2. Model designation of equipment that uses parts listed on this page.
3. Title and description of assembly.
4. Drawing numbers that correspond to key column numbers for parts identification.
5. Key column for locating parts shown on drawing.
6. Part number.
7. Quantity of parts used.
8. Description of each component part.
9. Serial number of unit the part fits.
10. Assembly or kit designated by Key 0 or ••/•.
11. Grouping index number.
12. Page number within the grouping index.
13. Manual title.
14. Page publication date.

NOTE: ⇨ Arrows always point toward the front of the engine.

Cylinder Block

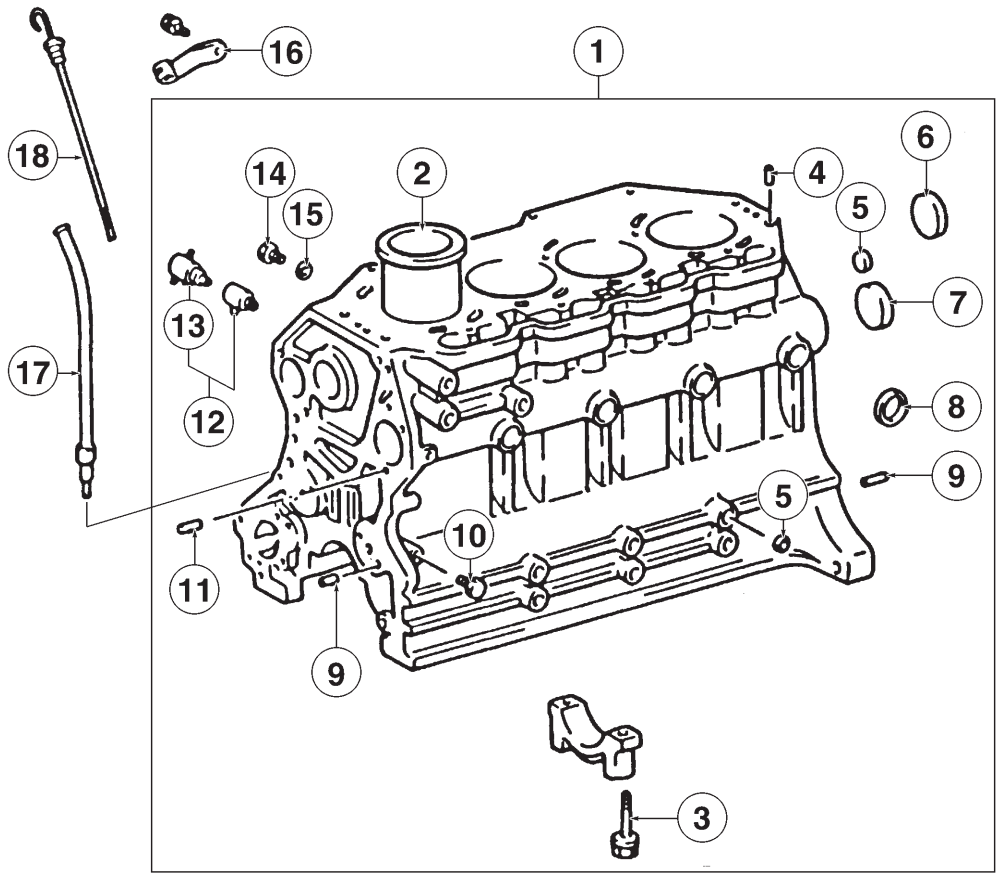

P984 01-00: 1105

KEY	PART NUMBER	QTY	DESCRIPTION	ENGINE BLOCK S/N
1	11401-78700-71	1	Cylinder Block Assembly	up to S/N - 0042812
2	11461-78700-71	4	Cylinder Liner (Dry Type) (Mark A)	-
	11461-78701-71	4	Cylinder Liner (Dry Type) (Mark B)	-
	11475-78300-71	**	Liner Shim T = 0.05" (not shown)	-
	11476-78300-71	**	Liner Shim T = 0.10" (not shown)	-
3	90105-14950-71	10	Bolt	-
4	90253-15950-71	2	Pin	-
5	90360-14950-71	2	Expansion Plug	-
6	96411-45000	2	Expansion Plug	-
7	90331-55950-71	1	Plug	-
8	96411-43500	7	Expansion Plug	-
9	90250-08120	6	Pin	-
10	90345-51003	1	Plug	-
11	90250-06068	2	Pin	-
12	96431-53828	1	Drain Cock (includes Key #13)	-
13	96432-23814	1	Drain Cock Plug	-
14	90341-10002	1	Plug	-
15	90430-10027	1	Gasket	-
16	11459-78301-71	1	Dipstick Tube Support	-
17	11452-78301-71	1	Dipstick Tube	-
18	15301-78700-71	1	Dipstick	-
			**As required.	

Cylinder Block

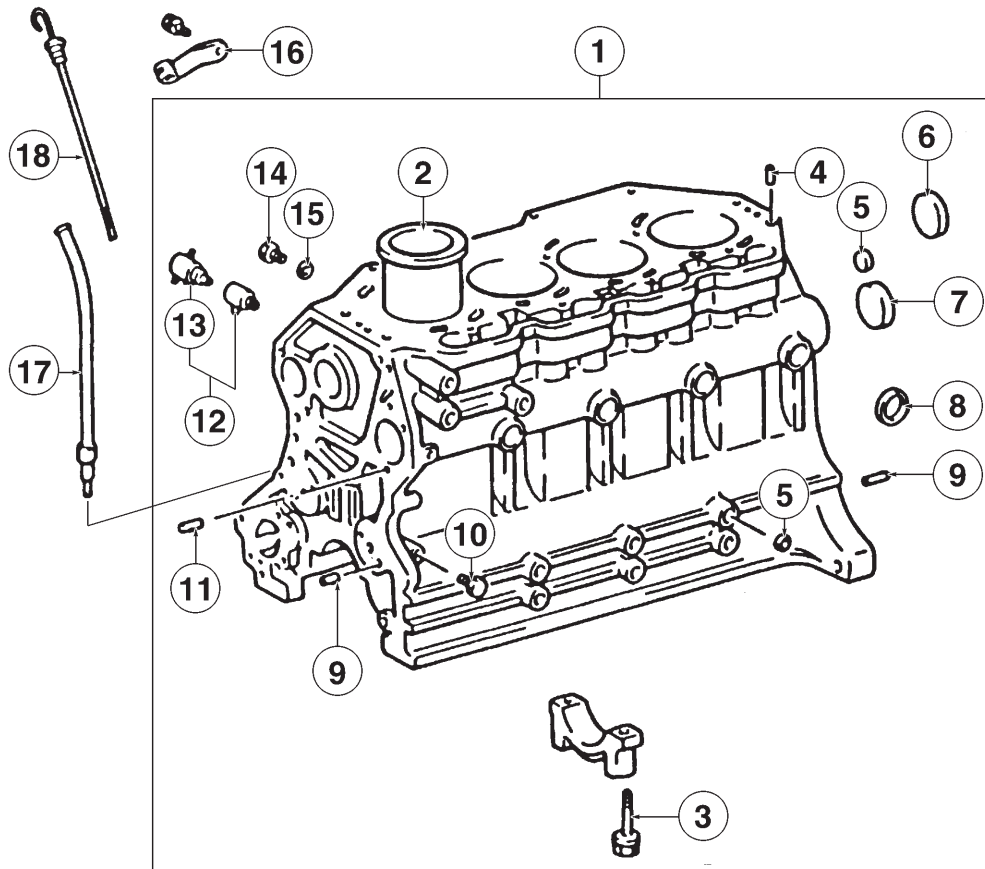

P984 01-00: 1105

KEY	PART NUMBER	QTY	DESCRIPTION	ENGINE BLOCK S/N
1	11401-78702-71	1	Cylinder Block Assembly (includes Pressure Relief Valve & standard Crankshaft Bearings)	from S/N 0042813 -
2	11461-78700-71	4	Cylinder Liner (Dry Type) (Mark A)	-
	11461-78701-71	4	Cylinder Liner (Dry Type) (Mark B)	-
	11475-78300-71	**	Liner Shim T = 0.05" (not shown)	-
	11476-78300-71	**	Liner Shim T = 0.10" (not shown)	-
3	90105-14950-71	10	Bolt	-
4	90253-15950-71	2	Pin	-
5	90360-14950-71	2	Expansion Plug	-
6	96411-45000	2	Expansion Plug	-
7	90331-55950-71	1	Plug	-
8	96411-43500	7	Expansion Plug	-
9	90250-08120	6	Pin	-
10	90345-51003	1	Plug	-
11	90250-06068	2	Pin	-
12	96431-53828	1	Drain Cock (includes key #13)	-
13	96432-23814	1	Drain Cock Plug	-
14	90341-10002	1	Plug	-
15	90430-10027	1	Gasket	-
16	11459-78301-71	1	Dipstick Tube Support	-
17	11452-78301-71	1	Dipstick Tube	-
18	15301-78700-71	1	Dipstick	-
			**As required	

Crankshaft, Pistons & Connecting Rods

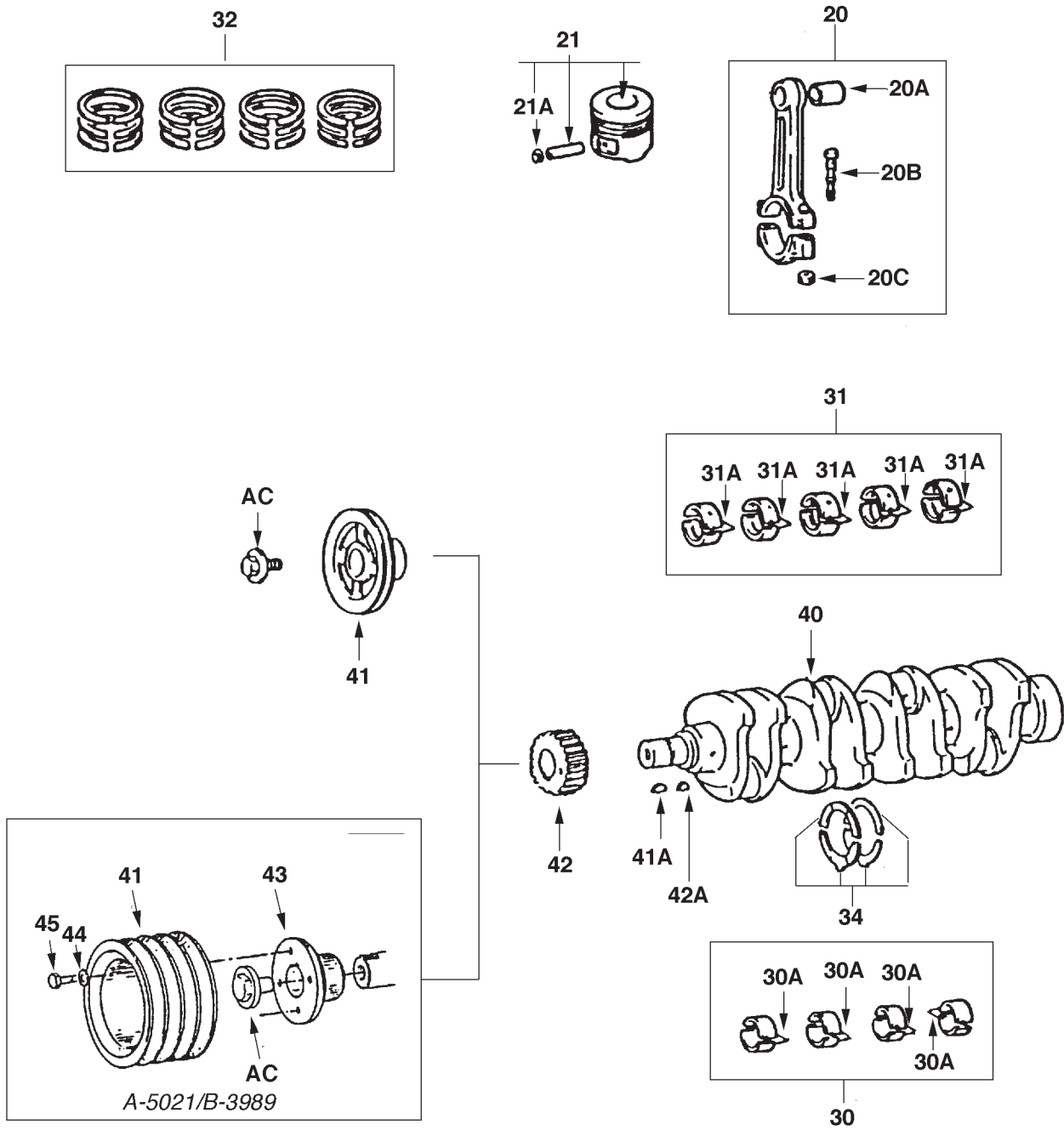

P984 01-02: A-5201 / B-3989 + 1301

Crankshaft, Pistons & Connecting Rods

KEY	PART NUMBER	QTY	DESCRIPTION	ENGINE BLOCK S/N
20	13201-78300-71	4	Connecting Rod Assembly	up to S/N - 0042812
20A	90384-32951-71	4	Wrist Pin Bushing	-
20B	13265-68010	8	Connecting Rod Bolt	-
20C	90179-12015	8	Nut	-
21	13101-78700-71	4	Piston Assembly, Standard (includes Key #21A)	-
	13103-78700-71	4	Piston Assembly, 0.50 mm O/S (includes Key #21A)	-
	13105-78700-71	4	Piston Assembly, 1.00 mm O/S (includes Key #21A)	-
21A	90521-34004	8	Snap Ring	-
30	13204-78300-71	1	Connecting Rod Bearing Set, 0.25 mm, Undersize	-
	13205-78300-71	1	Connecting Rod Bearing Set, 0.50 mm, Undersize	-
	13206-78300-71	1	Connecting Rod Bearing Set, 0.75 mm, Undersize	-
	13207-78300-71	1	Connecting Rod Bearing Set, 1.00 mm, Undersize	-
30A	13041-68040-01	4	Connecting Rod Bearing, Mark 1 - Standard	-
	13041-68040-02	4	Connecting Rod Bearing, Mark 2 - Standard	-
			Note: Standard size connecting rod bearings must be matched to rods stamped with Mark 1 or Mark 2.	
31	11704-78700-71	1	Main Bearing Set, 0.25 mm, Undersize	-
	11705-78700-71	1	Main Bearing Set, 0.50 mm, Undersize	-
	11706-78700-71	1	Main Bearing Set, 0.75 mm, Undersize	-
	11707-78700-71	1	Main Bearing Set, 1.00 mm, Undersize	-
31A	11701-78700-71	5	Main Bearing, Size 1 - Standard	-
	11701-78701-71	5	Main Bearing, Size 2 - Standard	-
	11701-78702-71	5	Main Bearing, Size 3 - Standard	-
			Note: Standard size main bearings must be matched to cylinder blocks with bearing caps stamped with Mark 1, Mark 2 or Mark 3.	
32	13011-78700-71	1	Piston Ring Set, Standard	-
	13013-78700-71	1	Piston Ring Set, 0.50 mm, Oversize	-
	13015-78700-71	1	Piston Ring Set, 1.00 mm, Oversize	-
34	11011-78300-71	1	Thrust Washer Set, Standard Only	-
	11012-78300-71	1	Thrust Washer Set O/S, 0.125 mm	-
	11013-78300-71	1	Thrust Washer Set O/S, 0.25 mm	-
40	13411-78700-71	1	Crankshaft	-
41	13471-78701-71	1	Crankshaft Pulley - Standard	-
	34-65401	1	Crankshaft Pulley - Optional	-
41A	95161-10519	1	Key	-
42	13521-78700-71	1	Crankshaft Timing Gear	-
42A	95161-10519	1	Key	-
43	34-65402	1	Mounting Flange	-
44	15-00701	4	Flat Washer M8	-
45	12-00712	4	Capscrew, Hex Head M8 x 1.25 x 25 mm	-
AC	90105-16950-71	1	Retaining Bolt - Standard Pulley	-
	90105-16951-71	1	Retaining Bolt - Optional Pulley	-

Crankshaft, Pistons & Connecting Rods

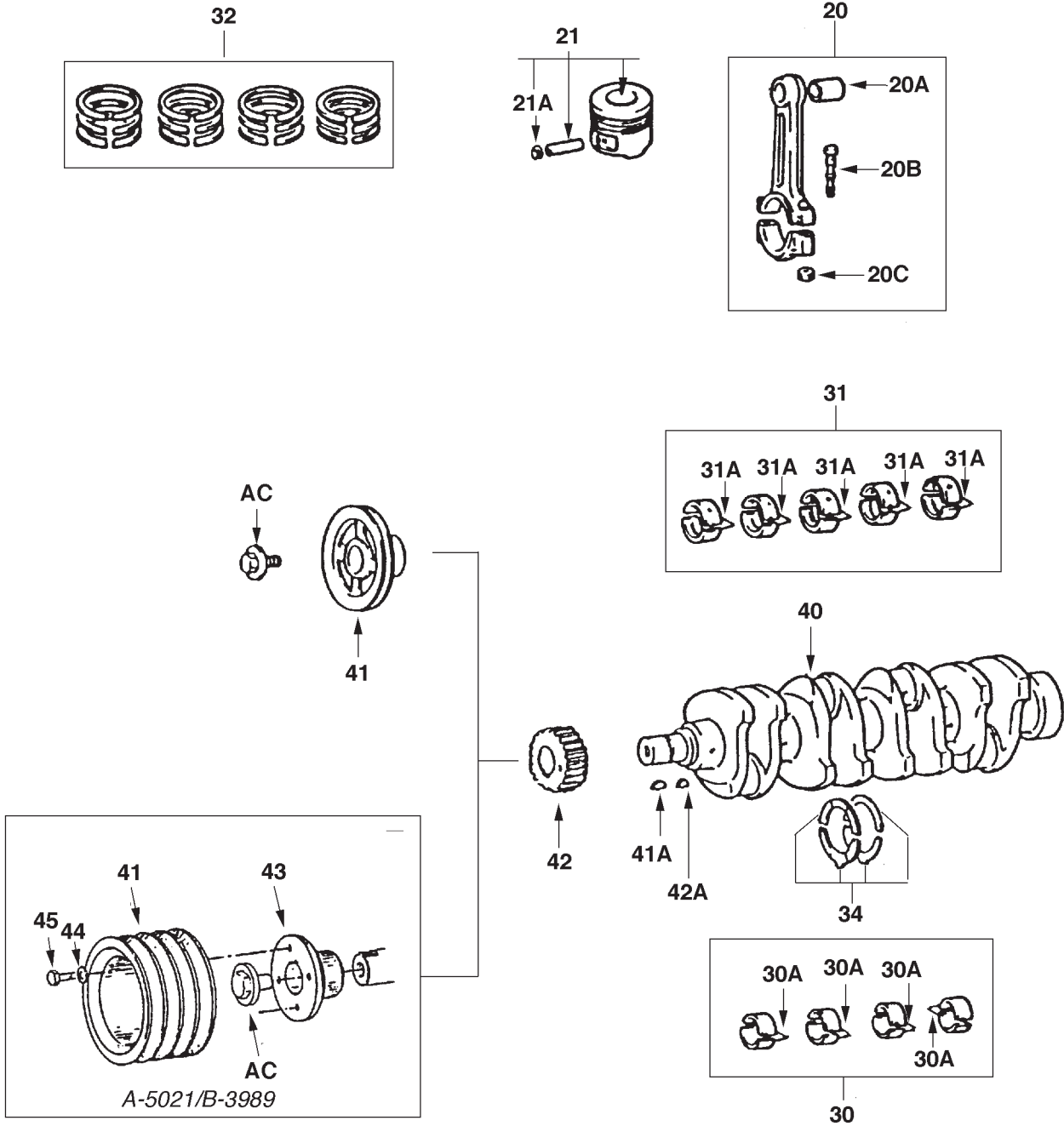

A-5201 / B-3989 + 1301

Crankshaft, Pistons & Connecting Rods

KEY	PART NUMBER	QTY	DESCRIPTION	ENGINE BLOCK S/N
20	13201-78300-71	4	Connecting Rod Assembly	from S/N 0042813 -
20A	90384-32951-71	4	Wrist Pin Bushing	-
20B	13265-68010	8	Connecting Rod Bolt	-
20C	90179-12015	8	Nut	-
21	13101-78702-71	4	Piston Assembly, Standard (includes key #21A)	-
	13103-78701-71	4	Piston Assembly, 0.50 mm O/S (includes key #21A)	-
	13105-78701-71	4	Piston Assembly, 1.00 mm O/S (includes key #21A)	-
21A	90521-34004	8	Snap Ring	-
30	13204-78300-71	1	Connecting Rod Bearing Set, 0.25 mm, Undersize	-
	13205-78300-71	1	Connecting Rod Bearing Set, 0.50 mm, Undersize	-
	13206-78300-71	1	Connecting Rod Bearing Set, 0.75 mm, Undersize	-
	13207-78300-71	1	Connecting Rod Bearing Set, 1.00 mm, Undersize	-
30A	13041-68040-01	4	Connecting Rod Bearing, Mark 1 - Standard	-
	13041-68040-02	4	Connecting Rod Bearing, Mark 2 - Standard	-
			Note: Standard size connecting rod bearings must be matched to rods stamped with Mark 1 or Mark 2.	
31	11704-78700-71	1	Main Bearing Set, 0.25 mm, Undersize	-
	11705-78700-71	1	Main Bearing Set, 0.50 mm, Undersize	-
	11706-78700-71	1	Main Bearing Set, 0.75 mm, Undersize	-
	11707-78700-71	1	Main Bearing Set, 1.00 mm, Undersize	-
31A	11701-78703-71	5	Main Bearing, Size 1 - Standard	-
	11701-78704-71	5	Main Bearing, Size 2 - Standard	-
	11701-78705-71	5	Main Bearing, Size 3 - Standard	-
	11701-78706-71	5	Main Bearing, Size 4 - Standard	-
	11701-78707-71	5	Main Bearing, Size 5 - Standard	-
	11701-78708-71	5	Main Bearing, Size 6 - Standard	-
			Note: Standard size main bearings must be matched to cylinder blocks with bearing caps stamped with Mark 1 through Mark 6.	
32	13011-78701-71	1	Piston Ring Set, Standard	-
	13013-78701-71	1	Piston Ring Set, 0.50 mm, Oversize	-
	13015-78701-71	1	Piston Ring Set, 1.00 mm, Oversize	-
34	11011-78300-71	1	Thrust Washer Set, Standard Only	-
	11012-78300-71	1	Thrust Washer Set O/S, 0.125 mm	-
	11013-78300-71	1	Thrust Washer Set O/S, 0.25 mm	-
40	13411-78701-71	1	Crankshaft	-
41	13471-78701-71	1	Crankshaft Pulley - Standard	-
	34-65401	1	Crankshaft Pulley - Optional	-
41A	95161-10519	1	Key	-
42	13521-78701-71	1	Crankshaft Timing Gear	-
42A	95161-10519	1	Key	-
43	34-65402	1	Mounting Flange	-
44	15-00701	4	Flat Washer M8	-
45	12-00712	4	Capscrew, Hex Head M8 x 1.25 x 25 mm	-
AC	90105-16950-71	1	Retaining Bolt - Standard Pulley	-
	90105-16951-71	1	Retaining Bolt - Optional Pulley	-

Flywheel and Housing

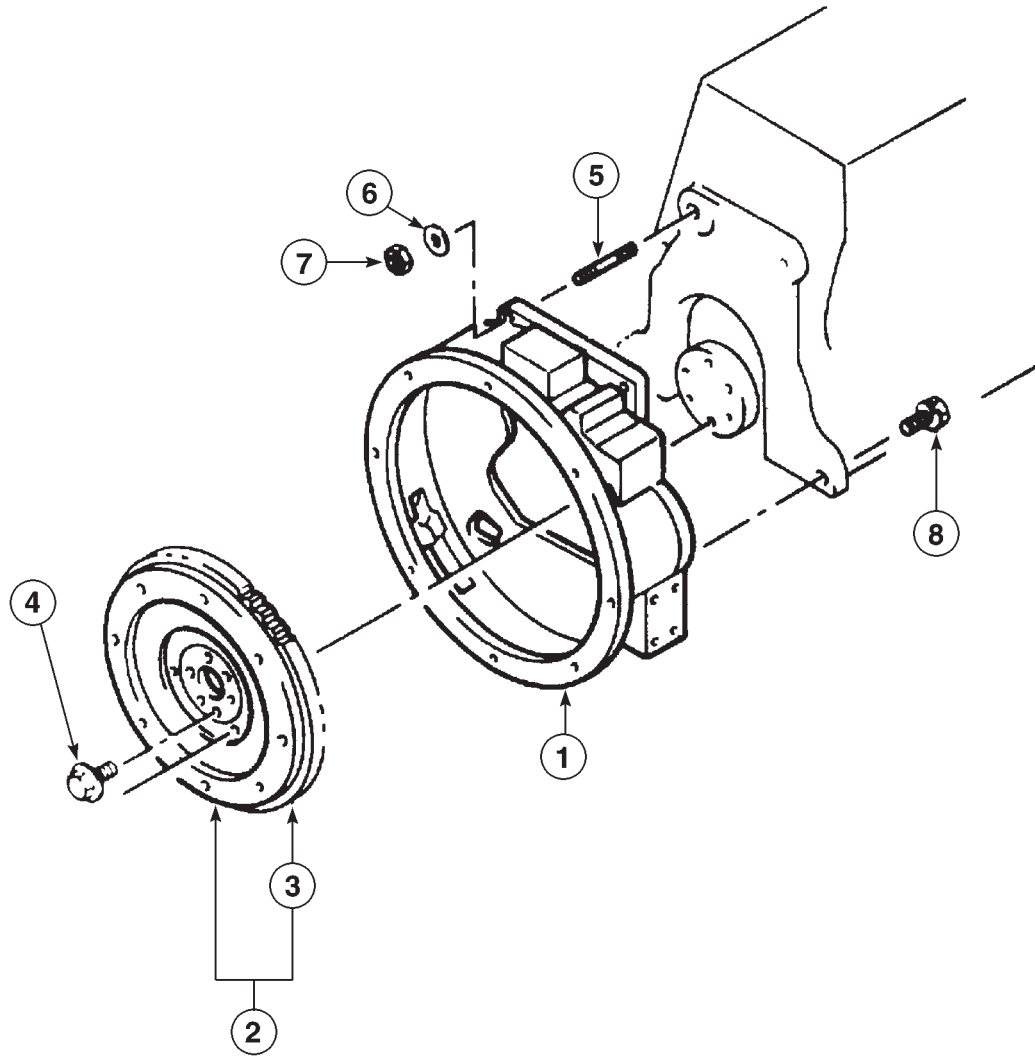

01-01: 3101

KEY	PART NUMBER	QTY	DESCRIPTION	SERIAL NUMBER
1	11351-78302-71	1	Flywheel Housing - SAE #4	-
2	13405-78302-71	1	Flywheel Assembly - SAE #10	-
3	13453-22060-71	1	Ring Gear - 108 Teeth	-
4	90105-12039	6	Washer Based Head Hexagon Bolt	-
5	90116-12950-71	2	Stud	-
	21-11002	**	Plug, 3/4-16 (not shown)	-
6	94512-01200	2	Washer	-
7	94115-51200	2	Nut	-
8	91619-61240	2	Bolt	-
			**As required.	

Lubrication System Components

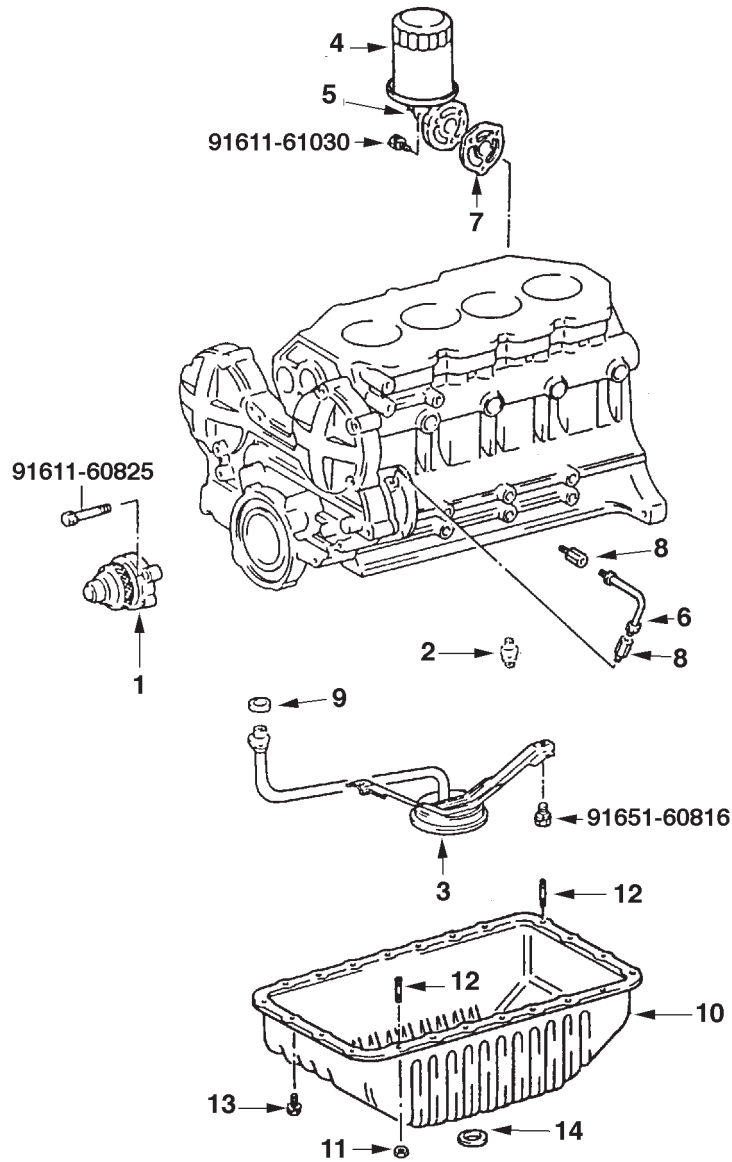

01-04: 1105 / 1501 / 1502

KEY	PART NUMBER	QTY	DESCRIPTION	ENGINE BLOCK S/N
1	15100-78700-71	1	Oil Pump Assembly	up to S/N - 004812
2	15310-78300-71	1	Oil Pressure Relief Valve (M18 Thread)	-
3	15104-78700-71	1	Strainer	-
4	24-05401	1	Oil Filter	-
5	15060-78300-71-A	1	Oil Filter Mount (formerly #15060-78300-71)	-
6	15702-78700-71	1	Tube Assembly	-
7	15691-78301-71	1	Gasket	-
8	90404-10023	2	Fitting	-
9	90430-17950-71	1	Gasket	-
10	12101-78700-71	1	Oil Pan	-
11	90179-08061	2	Nut	-
12	90116-08112	2	Stud	-
13	90119-08951	22	Bolt with Washer	-
14	90430-25003	1	Gasket	-

Lubrication System Components

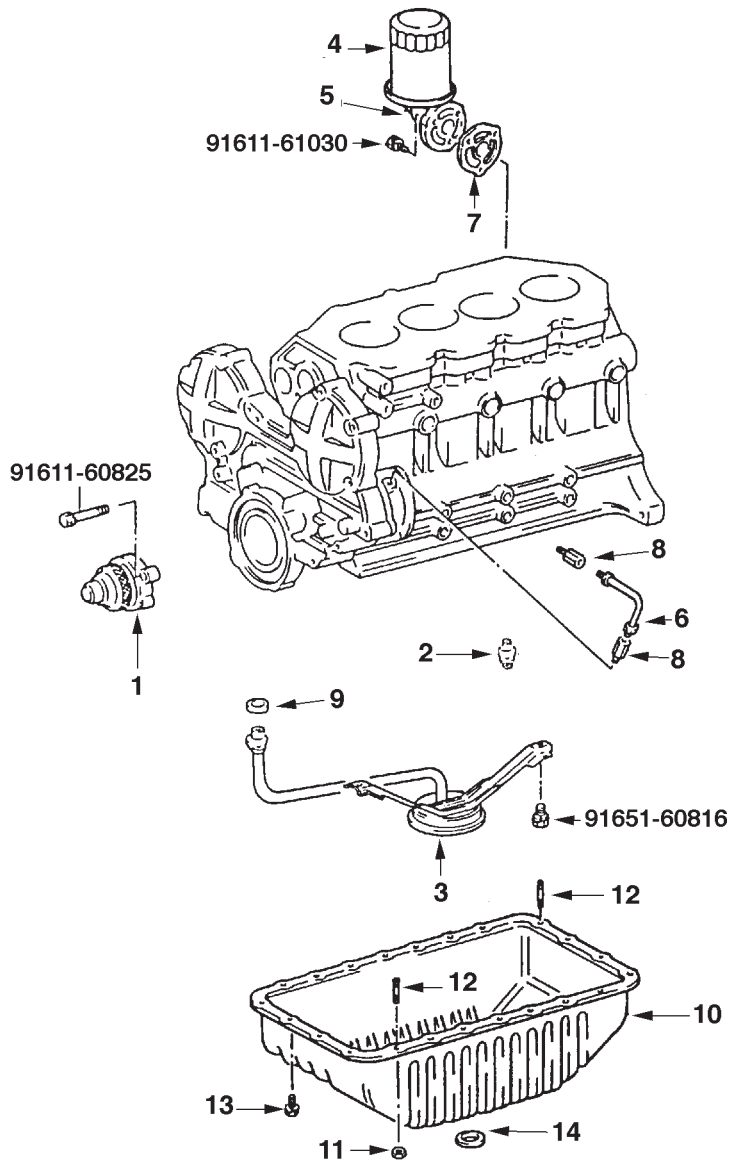

01-04: 1105 / 1501 / 1502

KEY	PART NUMBER	QTY	DESCRIPTION	ENGINE BLOCK S/N
1	15100-78700-71	1	Oil Pump Assembly	from S/N 0042813 -
2	15310-78700-71	1	Oil Pressure Relief Valve (M16 Thread)	-
3	15104-78700-71	1	Strainer	-
4	24-05401	1	Oil Filter	-
5	15608-78300-71	1	Oil Filter Mount	-
6	15702-78700-71	1	Tube Assembly	-
7	15691-78301-71	1	Gasket	-
8	90404-10023	2	Fitting	-
9	90430-17950-71	1	Gasket	-
10	12101-78700-71	1	Oil Pan	-
11	90179-08061	2	Nut	-
12	90116-08112	2	Stud	-
13	90119-08951	22	Bolt with Washer	-
14	90430-25003	1	Gasket	-

Timing Cover - P.T.O. & Rear Seal

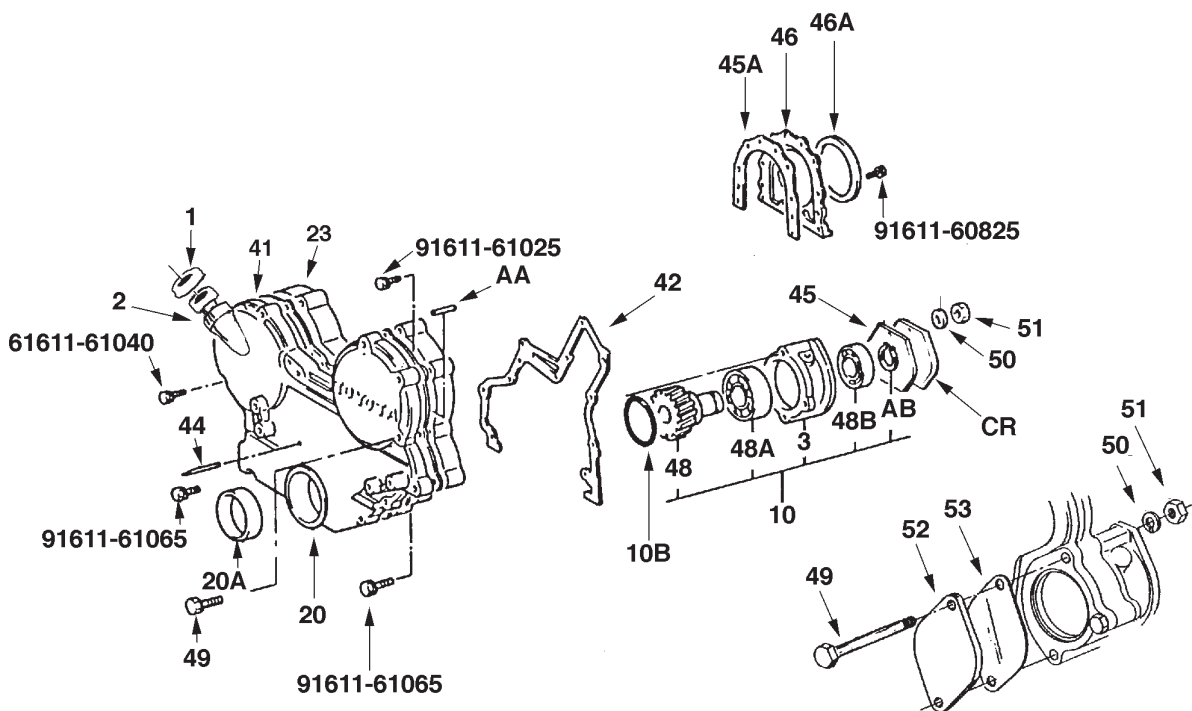

A-5035 / C-2607 + 1106

KEY	PART NUMBER	QTY	DESCRIPTION	SERIAL NUMBER
1	12180-76002-71	1	Filler Cap	-
2	15773-78300-71	1	Filler Neck	-
3	11314-78700-71	1	PTO Housing	-
10	11307-78302-71	1	PTO Assembly 9T (includes keys #3, #48, #48A, #48B & #AB)	-
10B	90301-81950-71	1	O-Ring	-
20	11321-78306-71	1	Timing Gear Cover	-
20A	90311-55950-71	1	Front Crankshaft Seal	-
23	11311-78700-71	1	Timing Gear Case	-
41	11328-78700-71	1	Gasket, Timing Gear Cover	-
42	11312-78330-71	1	Gasket, Timing Gear Case	-
44	11391-46010	1	Timing Pointer	-
45	11-75401	1	Gasket, Hydraulic Pump Flange	-
45A	11383-78700-71	1	Gasket, Rear Main Seal Retainer (formerly #11383-78330-71)	-
46	11381-78700-71	1	Retainer, Rear Main Seal (formerly #11381-78300-71)	-
46A	00-05408	1	Wear Sleeve, Repair Type (use with standard seal)	-
	90311-95951-71	1	Rear Main Seal (previously #90311-95950-71)	-
48	13519-78302-71	1	PTO/Raw Water Pump Drive Gear 9T	-
48A	90363-35950-71	1	Bearing	-
48B	97103-06006	1	Bearing	-
49	12-00837	2	Capscrew, Hex Head M10 x 1.5 x 150 mm	-
50	15-00802	2	Lock Washer M10	-
51	14-00811	2	Hex Nut M10 x 1.5	-
52	28-75403	1	Cover, Keel Cooling without Raw Water Pump	-
53	11-75402	1	Gasket	-
AA	90250-08120	3	Dowel Pin	-
AB	96150-03000	1	Snap Ring	-
BC	90341-10002	1	Plug (not shown)	-
BJ	90340-11027	1	Gasket (not shown)	-
CR	28-75001	1	PTO Cover (not shown)	-

Camshaft & Valve Train

KEY	PART NUMBER	QTY	DESCRIPTION	ENGINE BLOCK S/N
20	13901-78300-71	1	Shaft	up to S/N - 0042812
21	13810-78300-71	1	Rocker Shaft Assembly (includes keys 20, 22-25, & 56-59)	-
22	13811-78300-71	8	Rocker Arm	-
23	90913-05020	8	Valve Adjusting Screw	-
24	90501-16163	4	Compression Spring	-
25	90170-08094	8	Nut	-
26	90099-04557	5	Capscrew, Hex Head M8 x 1.25 x 60 mm	-
30	11802-78301-71	1	Camshaft Bearing Set, Standard	-
	11803-78300-71	1	Camshaft Bearing Set, 0.125 mm	-
	11804-78300-71	1	Camshaft Bearing Set, 0.25 mm	-
40	13511-78300-71	1	Camshaft	-
40B	90331-55950-71	1	Plug	-
41	13523-78700-71	1	Camshaft Timing Gear	-
42	13781-78300-71	8	Push Rod	-
43	13711-78300-71	4	Intake Valve	-
43A	90913-02044	8	Valve Stem Oil Seal	-
44	13715-78300-71	4	Exhaust Valve	-
45	13751-44030	8	Lifter, Standard	-
	13755-47011	8	Lifter O/S, 0.05 mm	-
46	90501-45228	8	Valve Spring	-
47	13741-46010	8	Valve Spring Retainer	-
47A	90913-03018	16	Valve Lock	-
48	13613-78700-71	1	Injection Pump Drive Gear (Generator Drive Units)	-
	13613-78701-71	1	Injection Pump Drive Gear (Propulsion Units)	-
49	13571-68010	1	Camshaft Thrust Plate	-
54	13525-78700-71	1	#1 Idler Gear	-
55	13581-78300-71	1	#1 Idler Gear Shaft	-
56	13951-78300-71	1	#1 Valve Rocker Support	-
57	13952-78300-71	2	#2 Valve Rocker Support	-
58	13953-78300-71	1	#3 Valve Rocker Support	-
59	13954-78300-71	1	#4 Valve Rocker Support	-
60	13572-78300-71	1	Idler Gear Thrust Plate	-
60A	90105-10950-71	2	Washer Based Head Hexagon Bolt	-
62	13509-78700-71	1	#2 Idler Gear Sub-Assembly	-
63	13573-78301-71	1	#2 Idler Gear Thrust Plate	-
63A	90105-10950-71	2	Washer Based Head Hexagon Bolt	-
64	13582-78700-71	1	#2 Idler Gear Shaft	-
AA	91611-40816	2	Bolt	-
AC	95161-10519	1	Key	-
AD	91619-61250	1	Bolt with Washer	-
AF	90201-12006	1	Washer	-
BG	91611-61020	2	Bolt with Washer	-
BI	13716-78300-71	8	Valve Stem Cap	-
CU	90201-50950-71	2	Washer	-

Camshaft & Valve Train

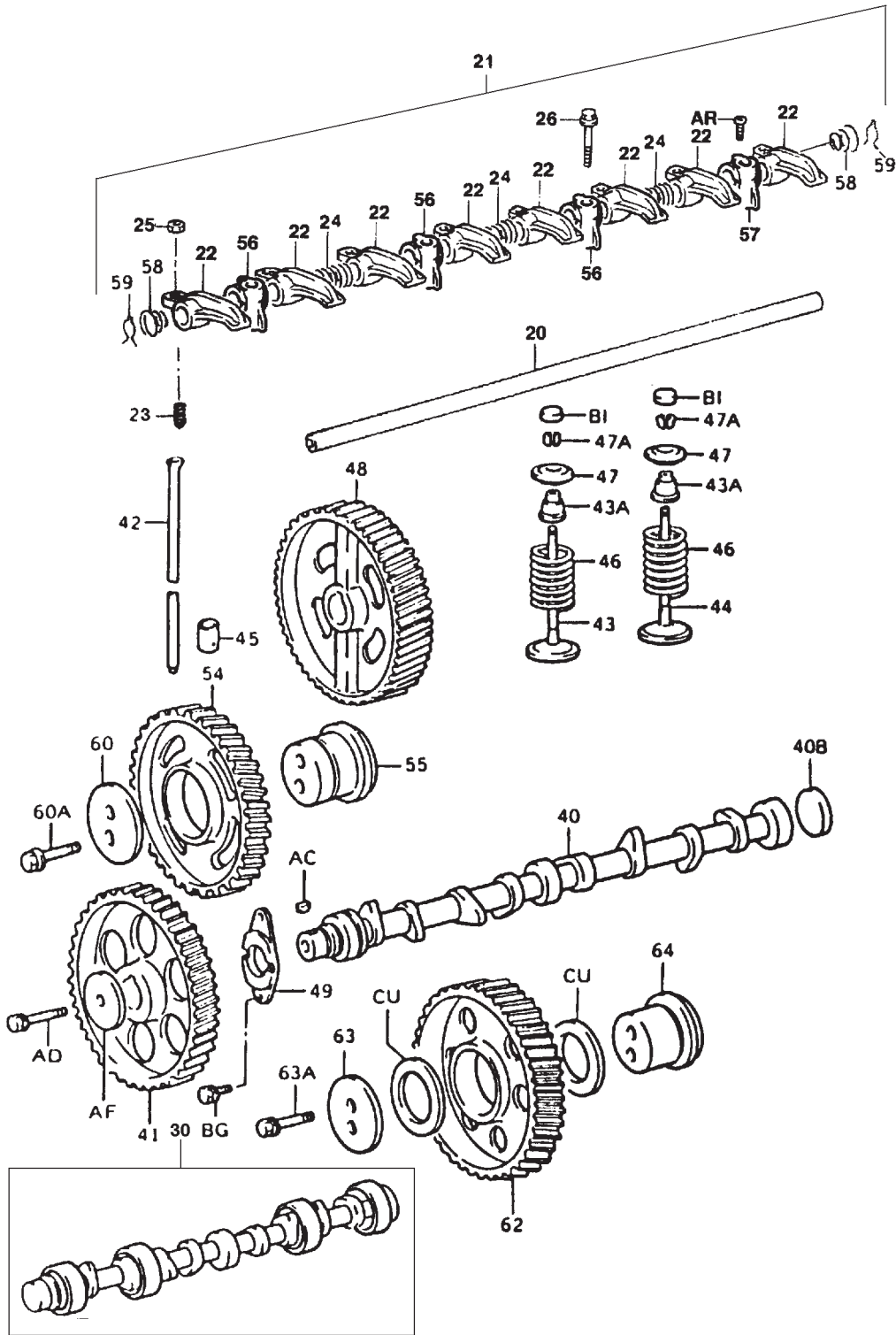

Camshaft & Valve Train

KEY	PART NUMBER	QTY	DESCRIPTION	ENGINE BLOCK S/N
20	13901-78700-71	1	Shaft	from S/N 0042813 -
21	13810-78700-71	1	Rocker Shaft Assembly (includes keys 22-25, & 56-59)	-
22	13811-78300-71	8	Rocker Arm	-
23	90913-05020	8	Valve Adjusting Screw	-
24	90501-16098	3	Compression Spring	-
25	90170-08094	8	Nut	-
26	91512-61060	4	Capscrew, Hex Head M10 x 1.25 x 60 mm	-
30	11802-78301-71	1	Camshaft Bearing Set, Standard	-
	11803-78300-71	1	Camshaft Bearing Set, 0.125 mm	-
	11804-78300-71	1	Camshaft Bearing Set, 0.25 mm	-
40	13511-78700-71	1	Camshaft	-
40B	90331-55950-71	1	Plug	-
41	13523-78701-71	1	Camshaft Timing Gear	-
42	13781-78300-71	8	Push Rod	-
43	13711-78300-71	4	Intake Valve	-
43A	90913-02044	8	Valve Stem Oil Seal	-
44	13715-78300-71	4	Exhaust Valve	-
45	13751-78700-71	8	Lifter	-
	13755-47011	8	Lifter O/S, 0.05 mm	-
46	90501-40950-71	8	Valve Spring	-
47	13741-46010	8	Valve Spring Retainer	-
47A	90913-03018	16	Valve Lock	-
48	13613-78702-71	1	Injection Pump Drive Gear (Generator Drive Units)	-
	13613-78703-71	1	Injection Pump Drive Gear (Propulsion Units)	-
49	13571-68010	1	Camshaft Thrust Plate	-
54	13525-78701-71	1	#1 Idler Gear	-
55	13581-78300-71	1	#1 Idler Gear Shaft	-
56	13951-78700-71	3	Rocker Support	-
57	13952-78700-71	2	Rocker Support	-
58	90502-16004	1	Spring	-
59	90524-15008	2	Spring Clip	-
60	13572-78300-71	1	Idler Gear Thrust Plate	-
60A	90105-10950-71	2	Washer Based Head Hexagon Bolt	-
62	13525-78701-71	1	#2 Idler Gear	-
63	13573-78301-71	1	#2 Idler Gear Thrust Plate	-
63A	90105-10950-71	2	Washer Based Head Hexagon Bolt	-
64	13582-78700-71	1	#2 Idler Gear Shaft	-
AR			Bolt	-
AA	91611-40816	2	Bolt (not shown)	-
AC	95161-10519	1	Key	-
AD	91619-61250	1	Bolt with Washer	-
AF	90201-12006	1	Washer	-
BG	91611-61020	2	Bolt with Washer	-
BI	13716-78300-71	8	Valve Stem Cap	-
CU	90201-50950-71	2	Washer	-

Cylinder Head & Valve Cover

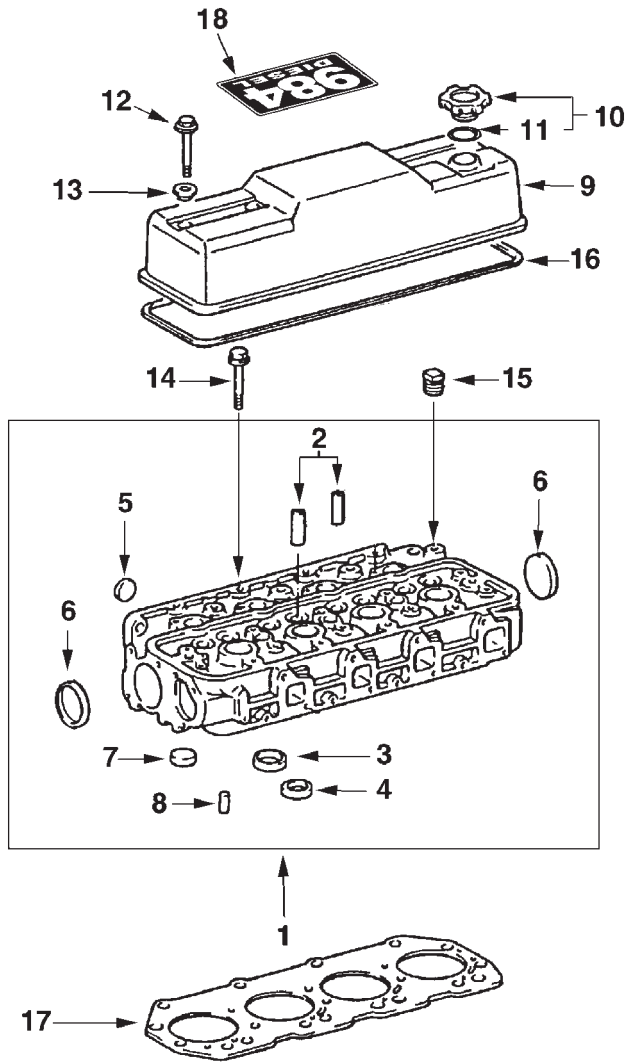

P984 01-09: 1104

KEY	PART NUMBER	QTY	DESCRIPTION	ENGINE BLOCK S/N
1	11101-78302-71	1	Cylinder Head (includes keys #2 - #8)	up to S/N - 0042812
2	11122-46010	8	Valve Guide	-
3	11131-68020	4	Intake Valve Seat	-
4	11135-68010	4	Exhaust Valve Seat	-
5	96411-43000	8	Expansion Plug	-
6	96411-45000	2	Expansion Plug	-
7	96411-43000	3	Expansion Plug	-
8	90440-15141	4	Tube	-
9	11201-78300-71	1	Rocker Arm Cover	-
10	12180-13030	1	Oil Filter Cap (includes key #11)	-
11	90430-37140	1	Gasket	-
12	91631-40840	4	Capscrew, Hex Head w/Washer M8 x 1.25 x 40 mm	-
13	90210-08007	4	Sealing Washer	-
14	90910-02070	18	Head Bolt M12 x 1.25 x 117 mm	-
15	90345-54005	1	Plug	-
16	11213-78300-71	1	Rocker Arm Cover Gasket	-
17	11115-78701-71	1	Cylinder Head Gasket (formerly #11115-78700-71)	-
18	00-05404	1	Label	-

Cylinder Head & Valve Cover

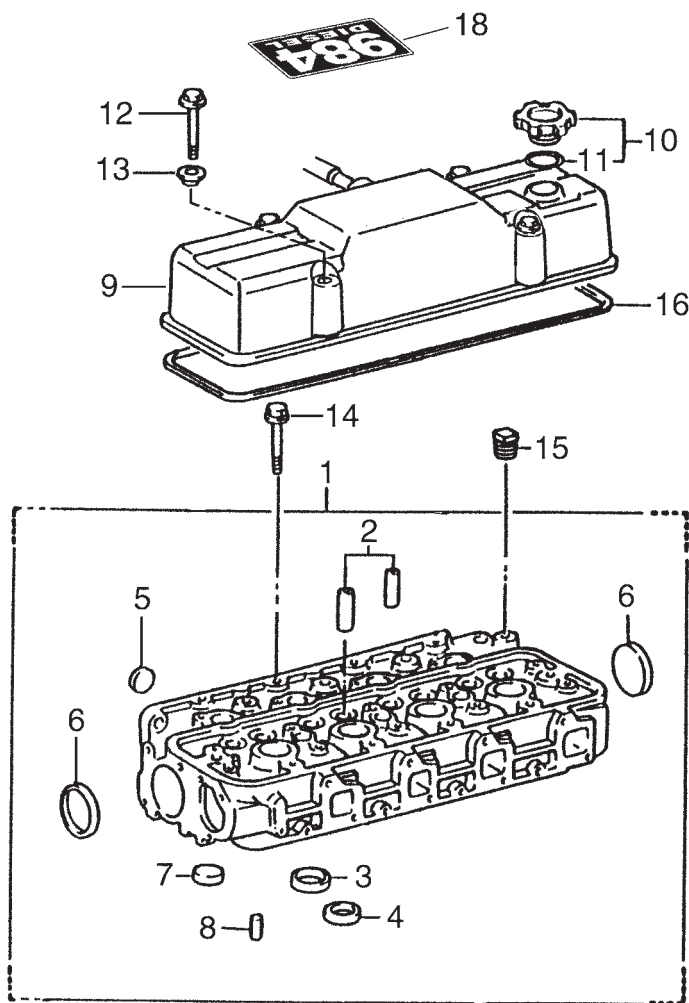

P984: TOYOTAROCKERCOVER

KEY	PART NUMBER	QTY	DESCRIPTION	ENGINE BLOCK S/N
1	11101-78700-71	1	Cylinder Head (includes keys #2 - #8)	from S/N 0042813 -
2	11122-46010	8	Valve Guide	-
3	11131-68020	4	Intake Valve Seat	-
4	11135-68010	4	Exhaust Valve Seat	-
5	96411-43000	8	Expansion Plug	-
6	96411-45000	2	Expansion Plug	-
7	96411-43000	3	Expansion Plug	-
8	90440-15141	4	Tube	-
9	11201-78700-71	1	Rocker Arm Cover	-
10	12180-13030	1	Oil Filter Cap (includes key #11)	-
11	90430-37140	1	Gasket	-
12	91621-60865	4	Capscrew, Hex Head w/Washer M8 x 1.25 x 65 mm	-
13	90210-08007	4	Sealing Washer	-
14	90910-02070	18	Head Bolt M12 x 1.25 x 117 mm	-
15	90345-54005	1	Plug	-
16	11213-78700-71	1	Rocker Arm Cover Gasket	-
17	11115-78701-71	1	Cylinder Head Gasket (not shown)	-
18	00-05404	1	Label	-

Oil Drain Kit

Northern Lights Application

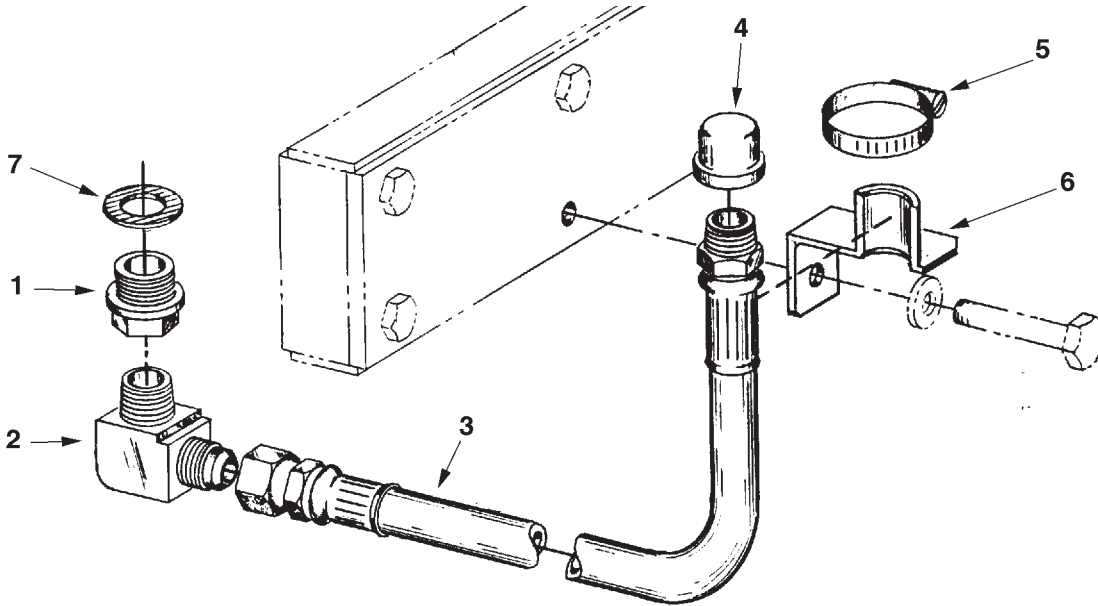

A-4348 / B-3669

KEY	PART NUMBER	QTY	DESCRIPTION	SERIAL NUMBER
1	36-75402	1	Oil Pan Drain Fitting	-
2	21-62508	1	Male Elbow 90° 3/8 NPT x 1/2-37T	-
3	18-75400	1	Hose Assembly 1/2" ID x 1/2 NPT x 1/2-37T	-
4	21-00003	1	Pipe Cap, 1/2 NPT	-
5	19-00010	1	Hose Clamp	-
6	23-75415	1	Oil Drain Hose Support Bracket	-
7	90430-25013	1	Gasket	-

GROUP 2 – INTAKE & EXHAUST SYSTEM

Air Intake & Vent Hose

Early Production Generator Sets and L984D

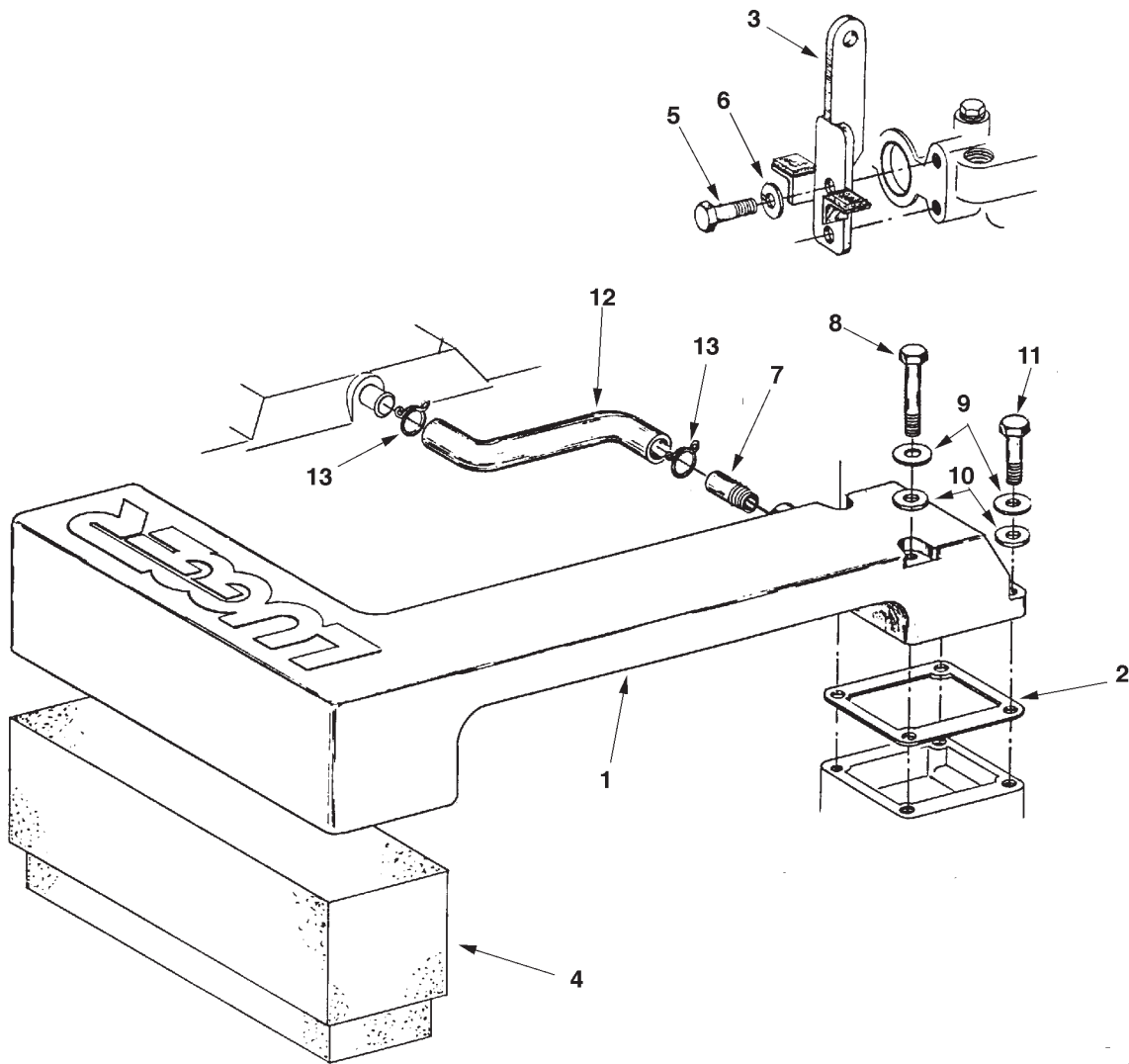

A-7044, A-7378, A-7869 / C-2334A

KEY	PART NUMBER	QTY	DESCRIPTION	SERIAL NUMBER
1	10-25401	1	Air Intake Manifold (Marine)	-
	10-25402	1	Air Intake Manifold (Lugger)	-
2	11-25400	1	Gasket	-
3	00-75402	1	Rear Lifting Eye	-
4	24-25401	1	Air Filter Element (Lugger)	-
	24-25402	1	Air Filter Element (Marine - see Intake Noise Reduction Assembly)	-
5	12-00809	2	Capscrew, Hex Head M10 x 1.25 x 25 mm	-
6	15-00802	2	Helical Lock Washer M10	-
7	21-25401	1	Male Connection 3/8 NPT x 5/8 HB	-
8	12-00754	2	Capscrew, Hex Head M8 x 1.25 x 85 mm	-
9	15-00701	4	Flat Washer, M8	-
10	16-25400	4	O-Ring	-
11	12-00713	2	Capscrew, Hex Head M8 x 1.25 x 35 mm	-
12	12261-78301-71	1	Vent Hose	-
13	90467-23002	2	Hose Clamp	-

Intake Noise Reduction

Marine Application - Early Production

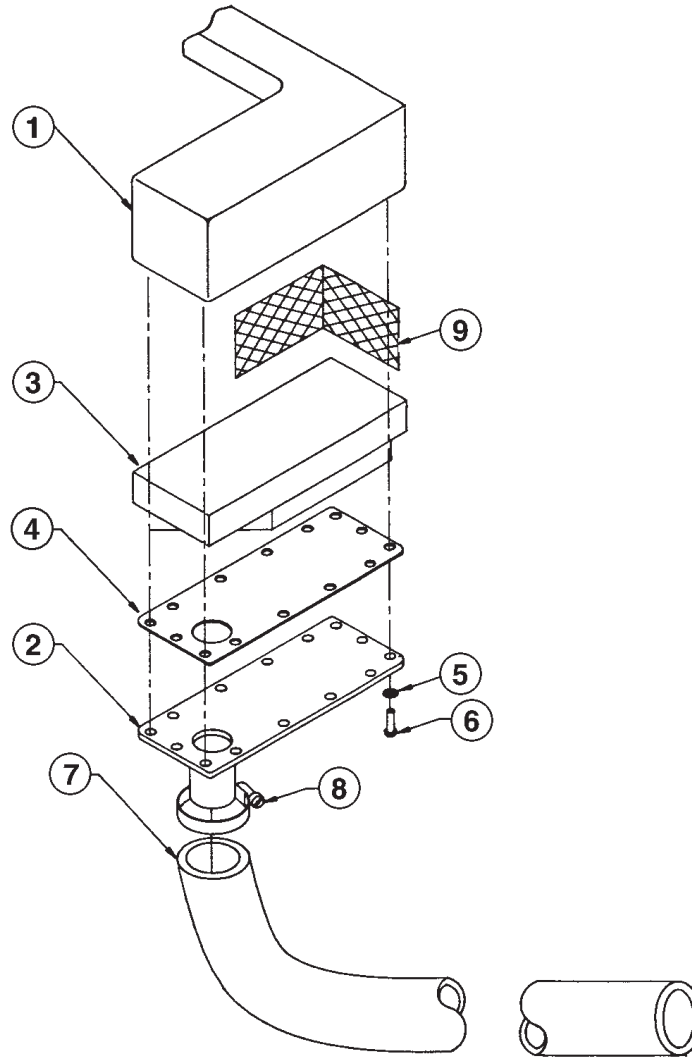

P984 02-01: B-4821

KEY	PART NUMBER	QTY	DESCRIPTION	SERIAL NUMBER
1	10-25401	1	Intake Manifold	-
2	28-25401	1	Cover Plate	-
3	24-25402	1	Air Filter Element	-
4	11-25401	1	Gasket	-
7	18-25403	1	Hose, Air Intake 2" ID x 65" (1500 RPM units)	-
	18-25402	1	Hose, Air Intake 2" ID x 54" (1800 RPM units)	-
8	19-00032	1	Hose Clamp #32	-
9	24-25403	1	Screen	-

GROUP 2 – INTAKE & EXHAUST SYSTEM

Air Intake & Vent Hose

Marine Application - Late Production

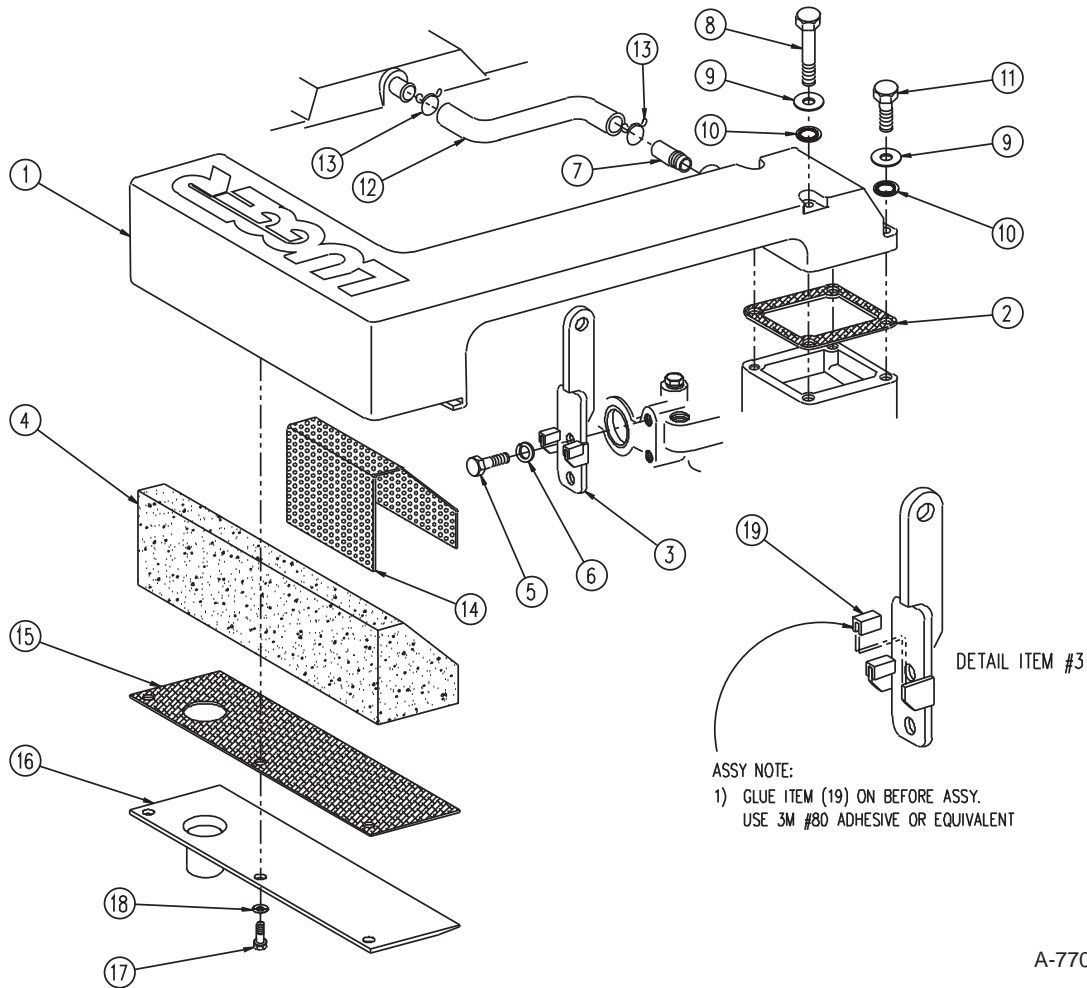

A-7708 / C-4057

KEY	PART NUMBER	QTY	DESCRIPTION	SERIAL NUMBER
1	10-25402	1	Air Intake Manifold	-
2	11-25400	1	Gasket	-
3	00-75482	1	Lifting Eye, Rear	-
4	24-25402	1	Air Filter Element	-
5	12-00809	2	Capscrew, Hex Head M10 x 1.25 x 25 mm	-
6	15-00802	2	Lock Washer, Helical M10	-
7	21-25401	1	Nipple, Plain, BP, 3/8 NPT x 1-1/4	-
8	12-00754	2	Capscrew, Hex Head M8 x 1.25 x 85 mm	-
9	15-00701	4	Flat Washer M8	-
10	16-25400	4	O-Ring, 8.5 mm x 18 mm x 3.2 mm	-
11	12-00713	2	Capscrew, Hex Head M8 x 1.25 x 35 mm	-
12	12261-78301-71	1	S-Hose	-
13	90467-23002	2	Hose Clamp	-
14	24-25405	1	Screen	-
15	11-25402	1	Gasket	-
16	28-25402	1	Plate	-
17	12-00209	3	Capscrew, Hex Head 5/16-18 x 3/4"	-
18	15-00203	3	Star Washer, Internal 5/16"	-
19	00-25401	**	Rubber Cushion Strip 7/8" LOA	-
	00-25402	**	Cushioned Steel U-Channel	-
			** As required.	

Intake Noise Reduction

Marine Application - Late Production

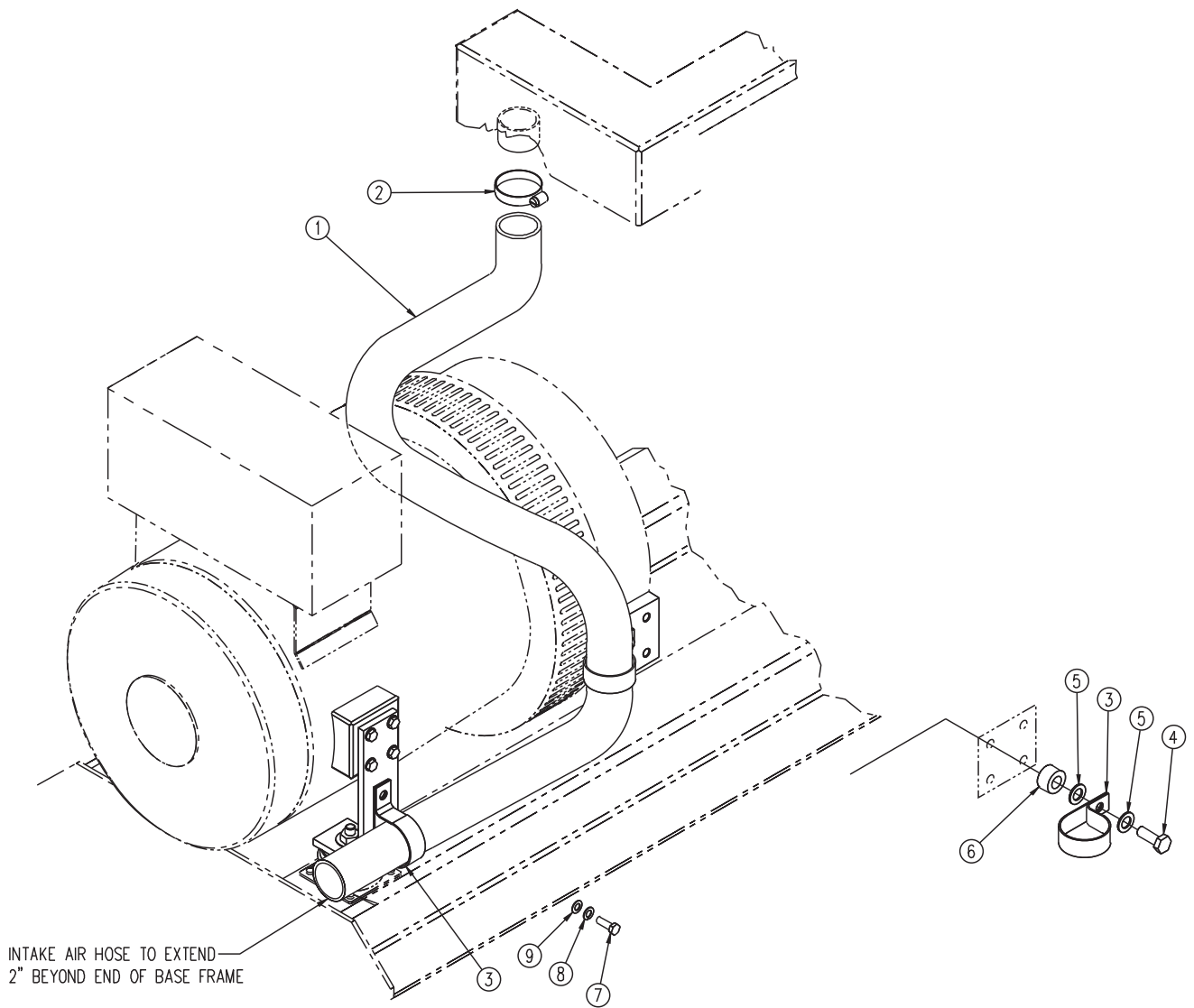

A-8483, A-8498 / C-4063

KEY	PART NUMBER	QTY	DESCRIPTION	SERIAL NUMBER
1	18-25402	1	Air Intake Hose, 2" ID x 54" (1800 RPM units)	-
	18-25403	1	Air Intake Hose, 2" ID x 65" (1500 RPM units)	-
2	19-00032	1	Hose Clamp #32	-
3	19-71035	2	Adelle Clamp 2-14" ID x 1/2" Stud	-
4	12-09516	1	Capscrew, Hex Head 1/2-13 x 2" Stainless Steel	-
5	15-00508	2	Flat Washer 1/2 SAE Stainless Steel	-
6	21-21004	1	Spacer, BP. 1/2 SCHD 40 x 13/16"	-
7	12-00776	1	Capscrew, Hex Head M8 x 1.25 x 20 mm Stainless Steel	-
8	15-00705	1	Lock Washer, Helical M8 Stainless Steel	-
9	15-00706	1	Flat Washer M8 Stainless Steel	-

Intake Manifold

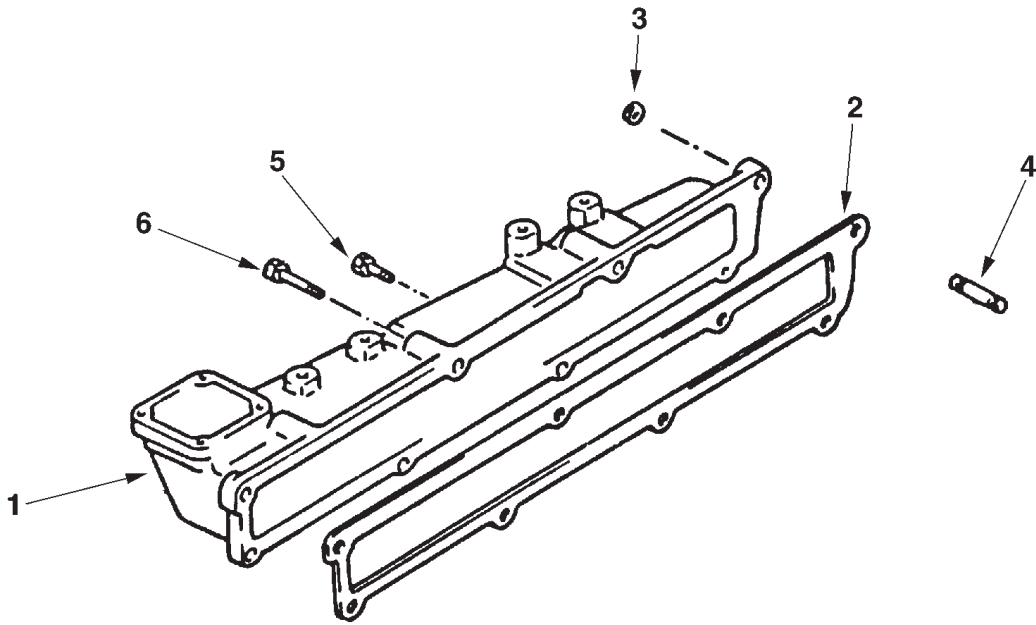

P984 02-04: 1701

KEY	PART NUMBER	QTY	DESCRIPTION	ENGINE BLOCK S/N
1	17111-78300-71	1	Intake Manifold	up to S/N -0042812 ↓
2	17171-78300-71	1	Intake Manifold Gasket	
3	90179-08061	3	Lock Nut, Flanged M8 x 1.25	
4	90116-08131	3	Stud M8 x 1.25 x 20 mm (30 mm LOA)	
5	91611-60825	3	Capscrew, Hex Head with Washer M8 x 1.25 x 25 mm	
6	91611-60865	3	Capscrew, Hex Head with Washer M8 x 1.25 x 65 mm	
<hr/>				
1	17111-78700-71	1	Intake Manifold	from S/N 0042813 - ↓
2	17171-78700-71	1	Intake Manifold Gasket	
3	90179-08061	3	Lock Nut, Flanged M8 x 1.25	
4	90116-08131	3	Stud M8 x 1.25 x 20 mm (30 mm LOA)	
5	91611-60825	6	Capscrew, Hex Head with Washer M8 x 1.25 x 25 mm	

Air Inlet

Commercial Application

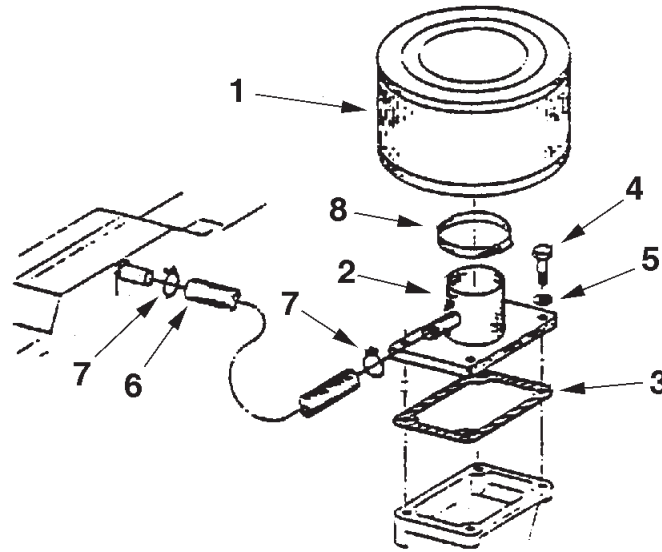

A-5546/ C-2716

KEY	PART NUMBER	QTY	DESCRIPTION	SERIAL NUMBER
1	24-20001	1	Air Filter	-
2	31-25401	1	Air Inlet Adapter	-
3	11-25400	1	Gasket	-
4	12-00712	4	Capscrew, Hex Head M8 x 1.25 x 25 mm	-
5	15-00702	4	Lock Washer M8	-
6	18-71010	1	Hose, 5/8" ID x 11"	-
7	19-00008	2	Hose Clamp #8	-
8	19-00040	1	Hose Clamp #40	-

Exhaust Manifold

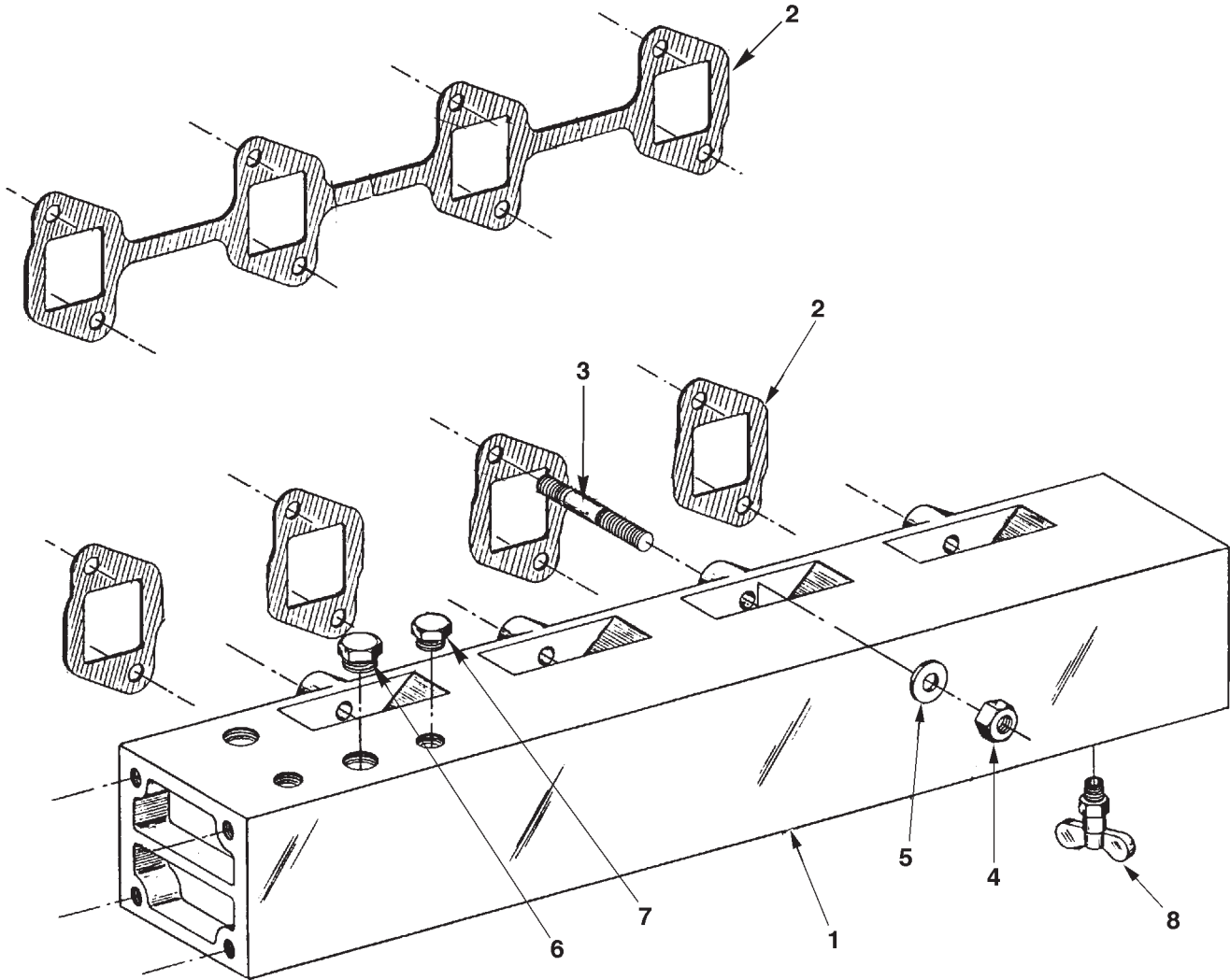

A-4213 / C-2337

KEY	PART NUMBER	QTY	DESCRIPTION	SERIAL NUMBER
1	10-35400	1	Exhaust Manifold	-
2	11-35402	4	Exhaust Manifold Gasket	-
	17173-78300-71	1	Exhaust Manifold Gasket (replaced by #11-35402)	-
3	13-35401	8	Stud, M10 x 1.25 x 35 mm (47 mm LOA)	-
4	14-00816	8	Hex Nut, M10 x 1.25 (14 mm Hex)	-
5	15-00805	8	Flat Washer, M10	-
6	21-00530	**	Hex Plug, brass 1/2 NPT	-
7	21-31003	**	Hex Plug, brass 3/8 NPT	-
8	21-10002	1	Drain Cock 1/4 NPT	-
9	17-10006	1	Expansion Plug 3/4" (not shown)	-
			**As required	

Wet Exhaust Elbow

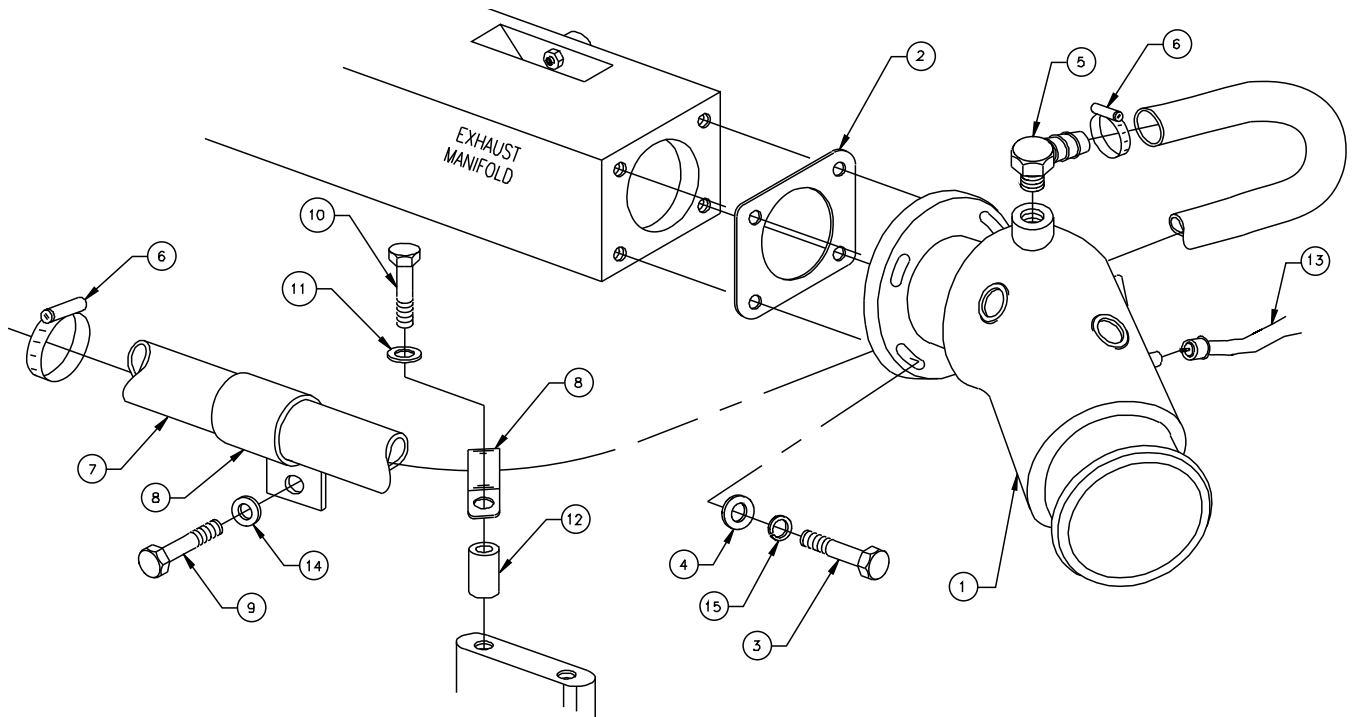

A-4246J / B-3608B

KEY	PART NUMBER	QTY	DESCRIPTION	SERIAL NUMBER
1	27-35400	1	Wet Exhaust Elbow (Cast Iron)	-
2	11-35401	1	Exhaust Gasket	-
3	12-00753	4	Capscrew, Hex Head M8 x 1.25 x 30 mm	-
4	15-35401	**	Flat Washer, Special	-
	15-00701	**	Flat Washer, M8	-
5	21-31902	1	Male Elbow 90°, 1/2 NPT x 3/4 HB	-
6	19-00010	2	Hose Clamp, #10	-
7	18-35404	1	Hose, 3/4" ID x 46" Wire Reinforced - HE units	-
	18-35403	1	Hose, 3/4" ID x 49" Wire Reinforced - KC units	-
8	19-71031	2	Adelle Clamp	-
9	12-00808	1	Capscrew, Hex Head M10 x 1.25 x 20 mm	-
10	12-00518	1	Capscrew, 1/2-13 x 2-1/2"	-
11	15-00007	1	Flat Washer	-
12	21-15403	1	Spacer, 1/2 ID x 1-5/8"	-
13	22-42014	1	Switch, High Exhaust Temperature	-
14	15-00805	1	Flat Washer	-
15	15-00702	4	Lock Washer	-
			** As required	

Dry Exhaust Elbow

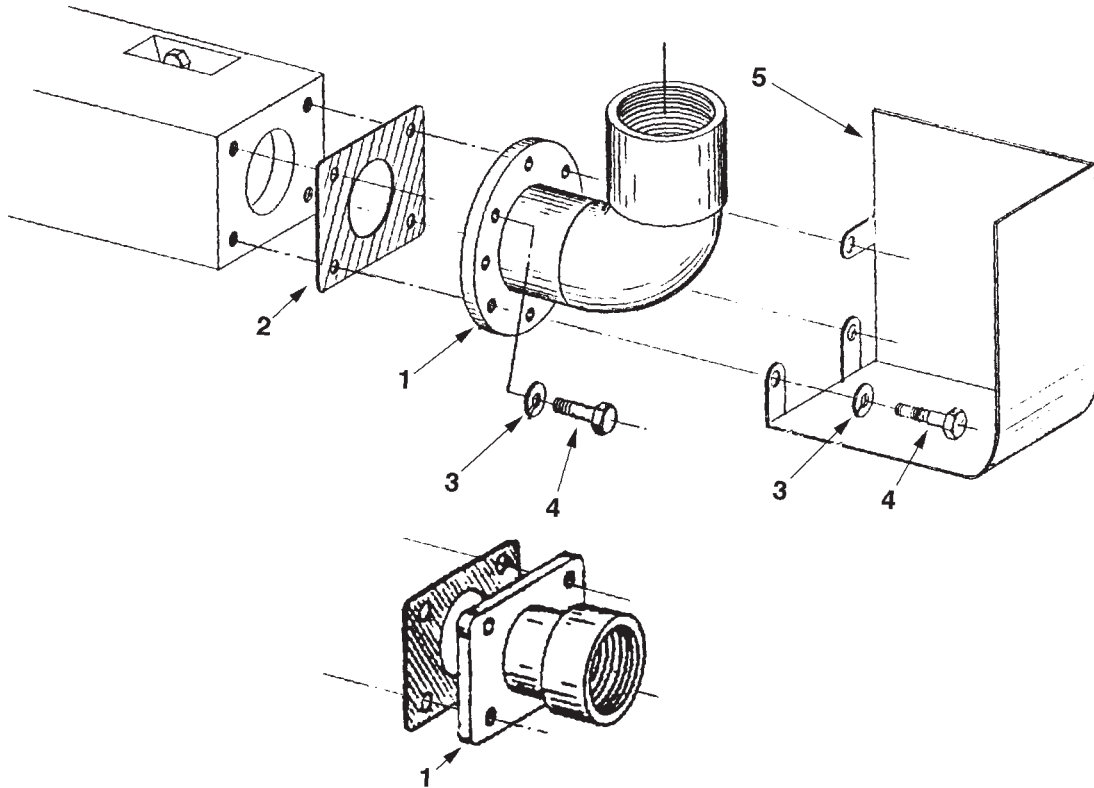

A-4267 / B-3632A

KEY	PART NUMBER	QTY	DESCRIPTION	SERIAL NUMBER
1	27-35405	1	Dry Exhaust Elbow	-
	31-35401	1	Dry Exhaust Adapter 2" NPT Female	-
2	11-35401	1	Exhaust Elbow Gasket	-
3	15-00702	4	Lock Washer, Helical M8	-
4	12-00711	4	Capscrew, Hex Head M8 x 1.25 x 20 mm	-
5	00-35402	1	Heat Shield	-

Expansion Tank & Thermostat Housing

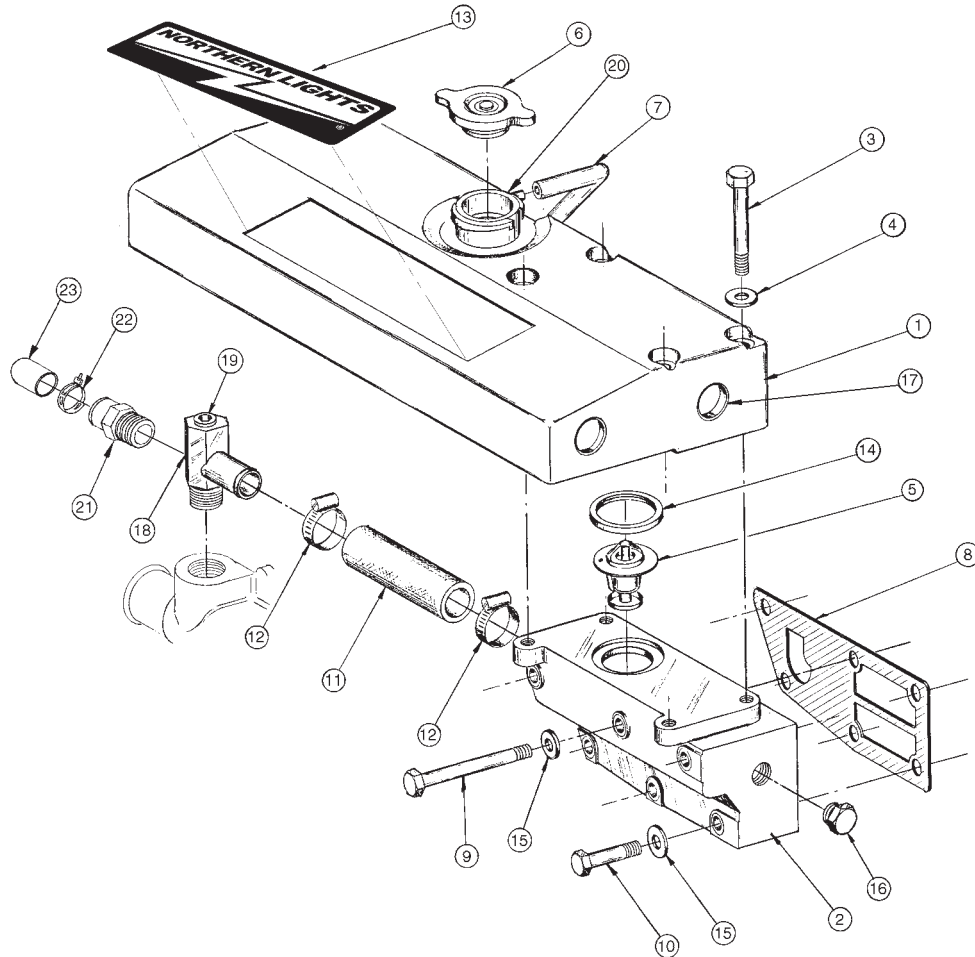

A-4211H / C-2336

KEY	PART NUMBER	QTY	DESCRIPTION	SERIAL NUMBER
1	10-12205	1	Expansion Tank	-
2	10-15401	1	Thermostat Housing	-
3	12-00819	4	Capscrew, Hex Head M10 x 1.5 x 75 mm	-
4	15-00805	4	Flat Washer, M10	-
5	35-10002	1	Thermostat	-
6	21-12013	1	Filler Cap	-
7	18-00130	1	Overflow Tube, 1/4" ID x 30"	-
8	11-15401	1	Gasket, Thermostat Housing	-
9	12-00800	3	Capscrew, Hex Head M10 x 1.25 x 100 mm	-
10	12-00803	3	Capscrew, Hex Head M10 x 1.25 x 65 mm	-
11	18-15401	1	Bypass Hose, 1" ID x 5-1/4" Silicon	-
12	19-00016	2	Hose Clamp #16	-
13	00-00006	1	"Northern Lights" Decal	-
	00-71000	1	"Lugger" Decal	-
14	11-10015	1	Seal Ring	-
15	15-00805	6	Flat Washer, M10	-
16	21-00530	1	Brass Hex Plug, 1/2 NPT	-
17	17-10054	4	Expansion Plug	-
18	21-15402	1	Elbow Fitting	-
19	21-12002	1	Socket Head Plug, Steel 3/8 BSPT	-
20	20-12207	1	Filler Neck	-
21	21-12014	1	Male Connector, Brass 3/8 NPT x 1/2" Hose Barb	-
22	19-18601	1	Clamp	-
23	21-18601	1	Cap	-

Heat Exchanger & Mounting

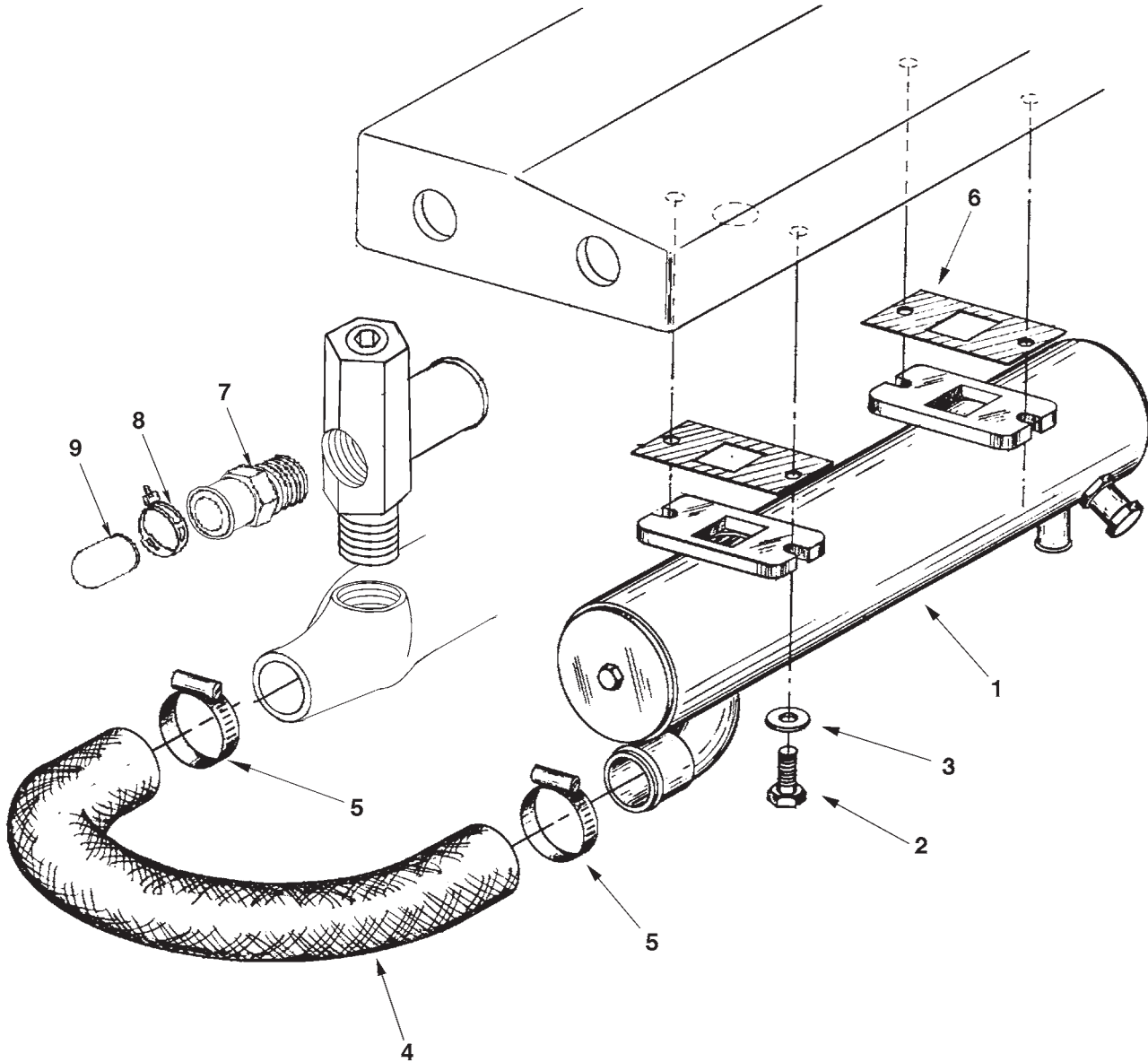

A-4221A / C-2341z

KEY	PART NUMBER	QTY	DESCRIPTION	SERIAL NUMBER
1	20-15410	1	Heat Exchanger Assembly - Lugger (see parts detail)	-
	20-15420	1	Heat Exchanger Assembly - Northern Lights (see parts detail)	-
2	12-00211	4	Capscrew, Hex Head 5/16 - 18 x 3/4"	-
3	15-00211	4	Flat Washer, 5/16"	-
4	18-15402	1	Hose - Northern Lights	-
	18-15407	1	Hose - Lugger	-
5	19-00024	2	Hose Clamp #24	-
6	11-12203	2	Gasket	-
7	21-12014	1	Male Connector 3/8 NPT x 1/2" Hose Barb	-
8	19-18601	1	Clamp	-
9	21-18601	1	Cap	-

Heat Exchanger Assembly

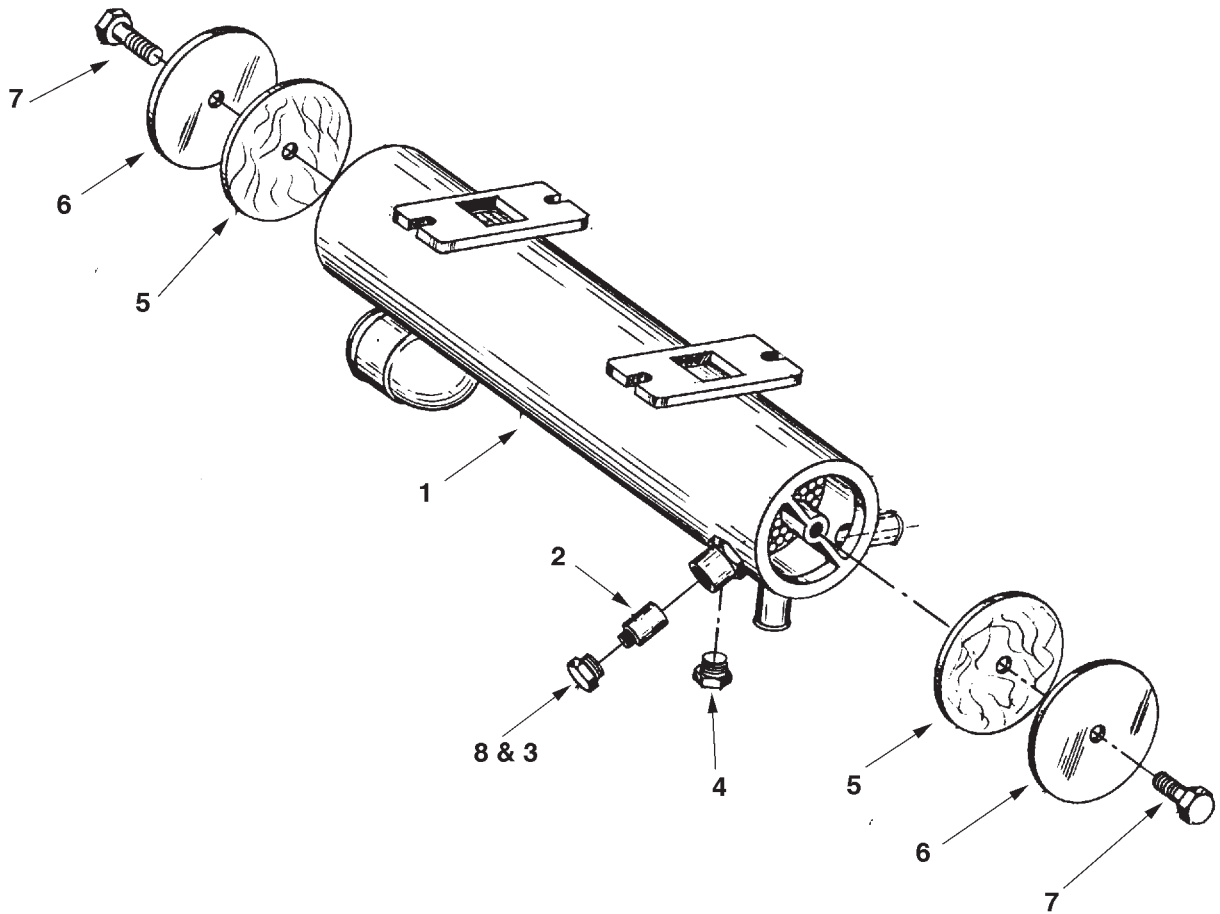

A-4219 / C-2339

KEY	PART NUMBER	QTY	DESCRIPTION	SERIAL NUMBER
••	20-15410	1	Heat Exchanger Assembly - Northern Lights (includes all Keys)	-
••	20-15420	1	Heat Exchanger Assembly - Luger (includes all Keys)	-
1	20-15400	1	Heat Exchanger - Northern Lights	-
	20-15401	1	Heat Exchanger - Luger	-
2	21-12010	1	Zinc Electrode	-
3	21-12000	1	Brass Plug, 1/4 NPT x 5/16-18	-
4	21-31624	1	Brass Plug, 1/4 NPT	-
5	20-12012	2	Heat Exchanger Gasket, 3"	-
6	28-12201	2	Heat Exchanger End Plates, 3"	-
7	12-11002	2	Capscrew, Hex Head Stainless Steel 3/8-16 x 3/4"	-
8	00-11003	1	Label "Zinc"	-

Coolant Pump

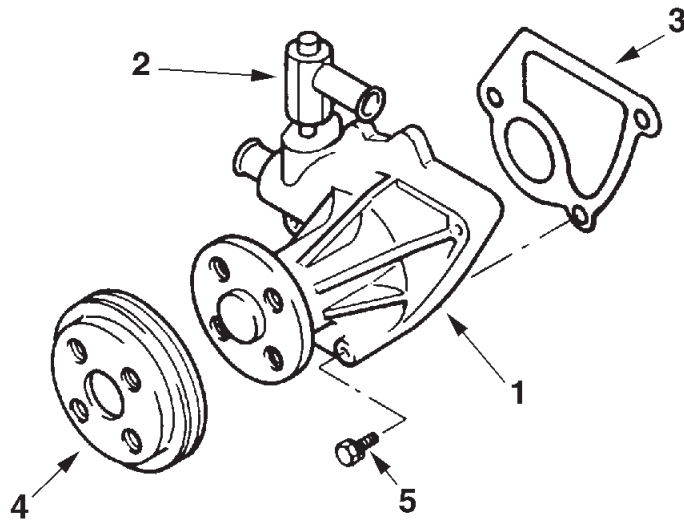

P984 03-04: 1601

KEY	PART NUMBER	QTY	DESCRIPTION	SERIAL NUMBER
1	16100-78700-71	1	Coolant Pump Assembly (parts not available separately - includes Key #2)	-
2	21-15402	1	Elbow Fitting with 3/8 BSPT Heater Outlet	-
3	16271-78302-71	1	Gasket	-
4	16371-78300-71	1	Pulley	-
5	81611-76083-71	1	Bolt with Washer	-

Keel Cooling Outlet

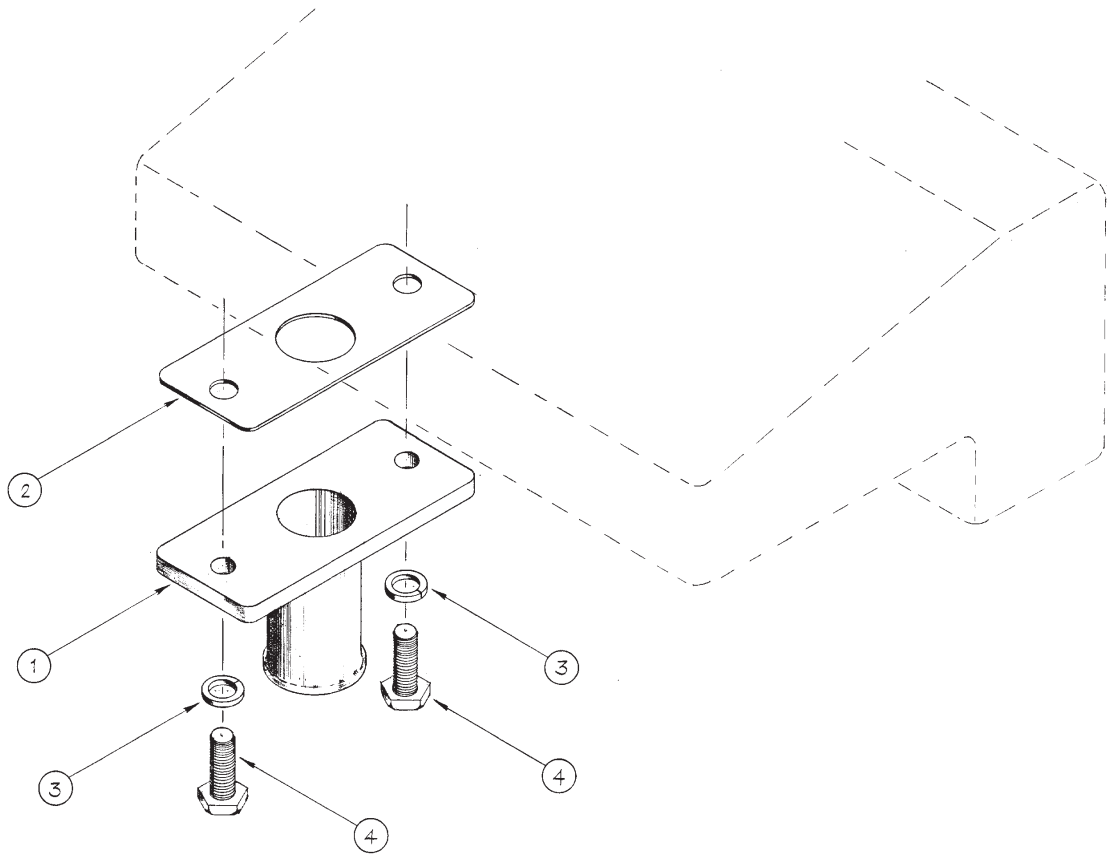

A-4400 / B-1700

KEY	PART NUMBER	QTY	DESCRIPTION	SERIAL NUMBER
1	31-15402	1	Keel Cooling Adapter	-
2	11-12203	1	Gasket	-
3	15-00202	2	Lock Washer, 5/16"	-
4	12-00212	2	Capscrew, 5/16 - 18 x 1"	-

Raw Water Pump & Mounting

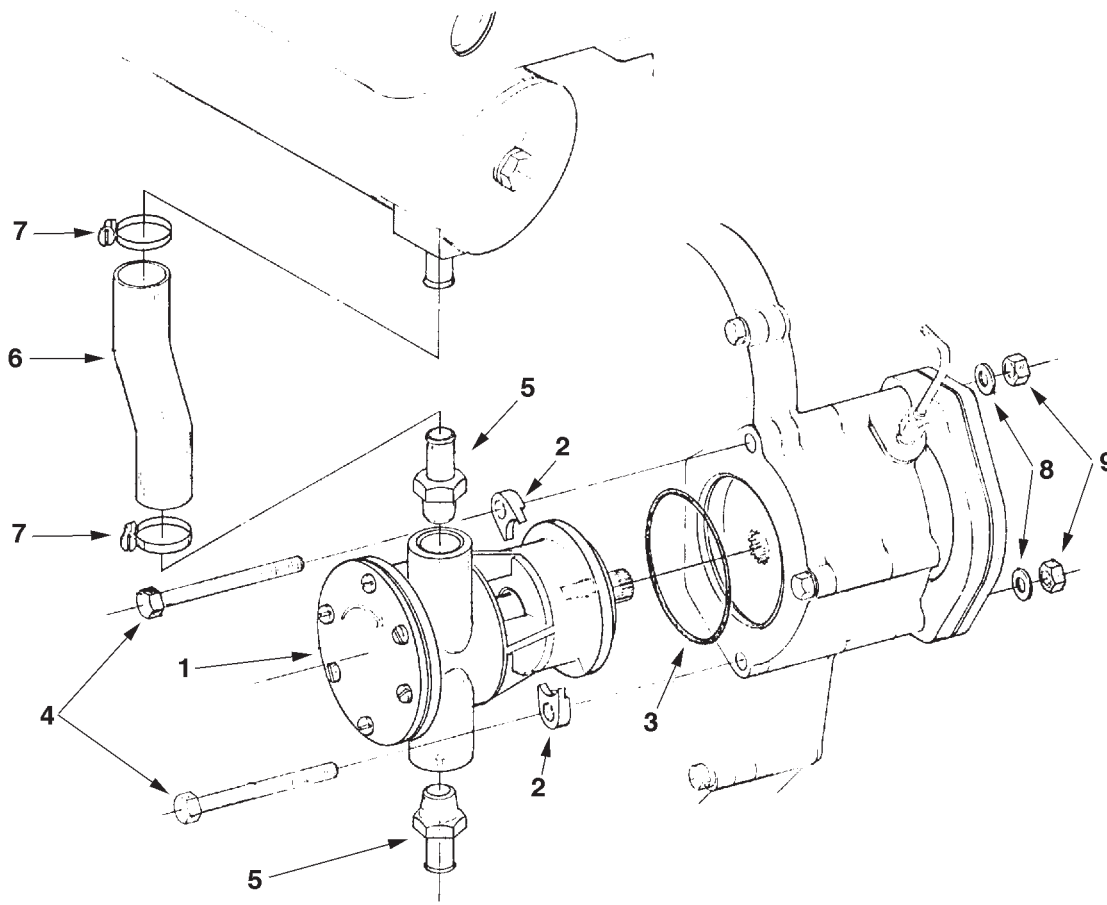

A-4706 / C-2459

KEY	PART NUMBER	QTY	DESCRIPTION	SERIAL NUMBER
1	25-15405	1	Raw Water Pump (see parts detail)	-
2	00-15401	2	Mounting Clip	-
3	16-15401	1	O-Ring	-
4	12-34800	2	Capscrew, Hex Head M10 x 1.5 x 160 mm	-
5	21-00129	2	Brass Male Connection, 1/2 NPT x 3/4 HB	-
6	18-15404	1	Wire Reinforced Hose, 3/4" ID	-
7	19-00010	2	Hose Clamp #10	-
8	15-00802	2	Lock Washer M10	-
9	14-00811	2	Hex Nut M10 x 1.5	-

Raw Water Pump Detail

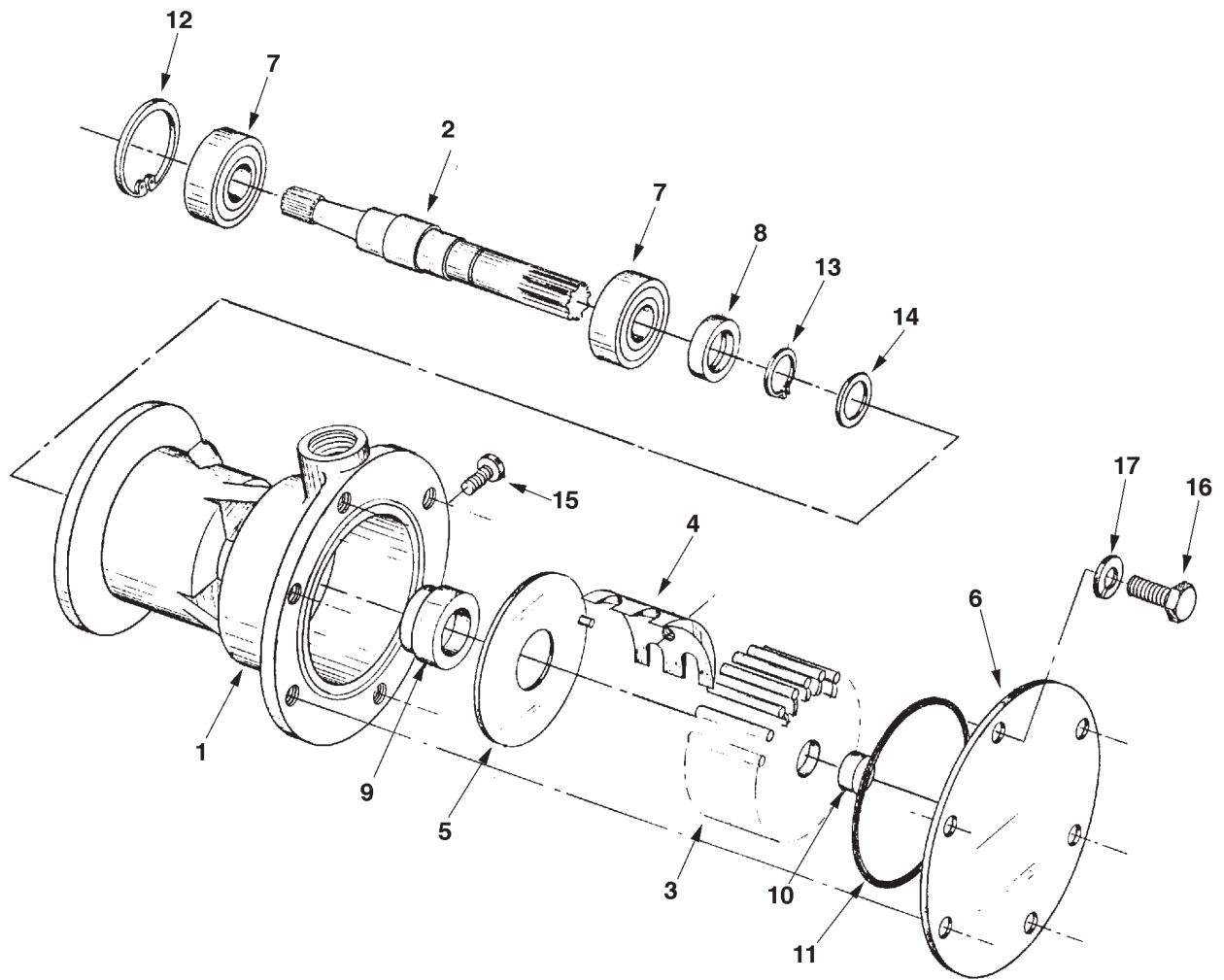

A-4761 / C-2477

KEY	PART NUMBER	QTY	DESCRIPTION	SERIAL NUMBER
••	25-15405	1	Raw Water Pump Assembly (includes all keys)	-
•	25-12004	1	Repair Kit (includes keys #3 - #9, #11)	-
1	25-15407	1	Pump Housing	-
2	25-15406	1	Shaft	-
3	25-12060	1	Impeller (includes key #11)	-
4	25-12061	1	Cam	-
5	25-12062	1	Wear Plate	-
6	25-12063	1	End Cover	-
7	25-12064	1	Bearing	-
8	25-12065	1	Lip Seal	-
9	25-12066	1	Mechanical Seal	-
10	25-12017	1	Spline Seal	-
11	25-12067	1	O-Ring	-
12	25-12068	1	Retaining Ring	-
13	25-12069	1	Retaining Ring	-
14	25-12070	1	Washer	-
15	25-12071	1	Pan Head Screw #10-32 x 3/8	-
16	25-12072	6	Hex Head Screw #10-32 x 3/8	-
17	25-12073	6	Lock Washer #10	-

Injectors & Lines: M984

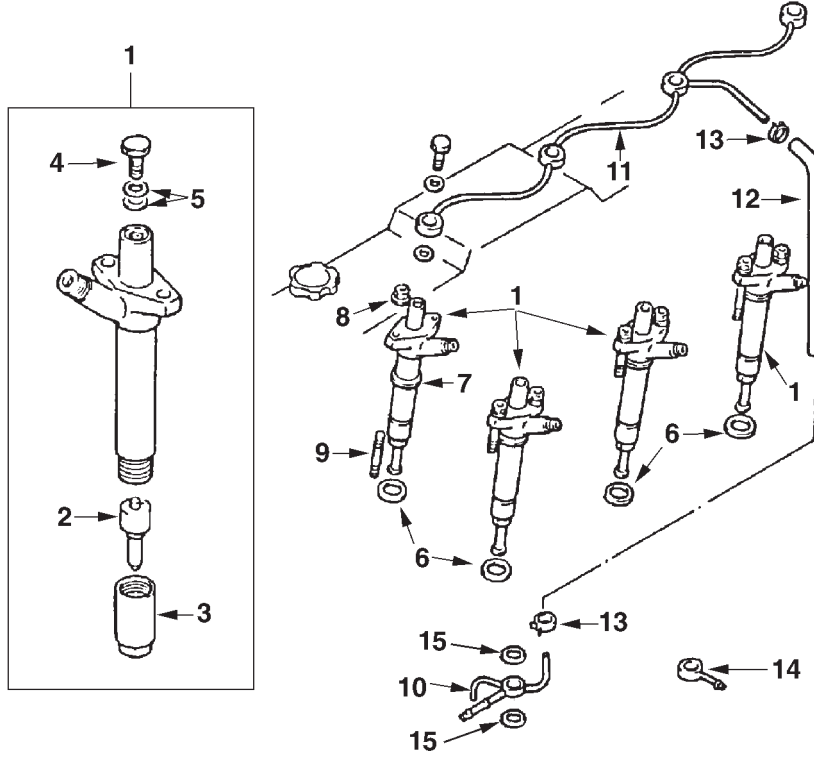

P984 04-00: 2201

KEY	PART NUMBER	QTY	DESCRIPTION	SERIAL NUMBER
1	23600-78300-71	4	Injector	-
2	23620-78300-71	1	Nozzle (marked DLLA150P35)	-
3	23624-58010	1	Nozzle Retaining Nut	-
4	23625-58230	4	Banjo Bolt	-
5	90201-08106	8	Washer	-
6	11176-56020	4	Injection Nozzle Seat	-
7	90430-18014	4	Gasket	-
8	90179-08061	8	Nut	-
9	90116-08234	8	Stud	-
10	23770-68030	1	Banjo Union - Fuel Return	-
11	23760-78300-71	1	Fuel Return Pipe	-
12	18-55403	1	Hose, 3/16" ID x 14"	-
13	96132-30400	2	Hose Clamp	-
14	90405-08128	1	Banjo Union - Fuel Supply	-
15	07005-01412	2	Sealing Washer M14	-

Injectors & Lines: L984

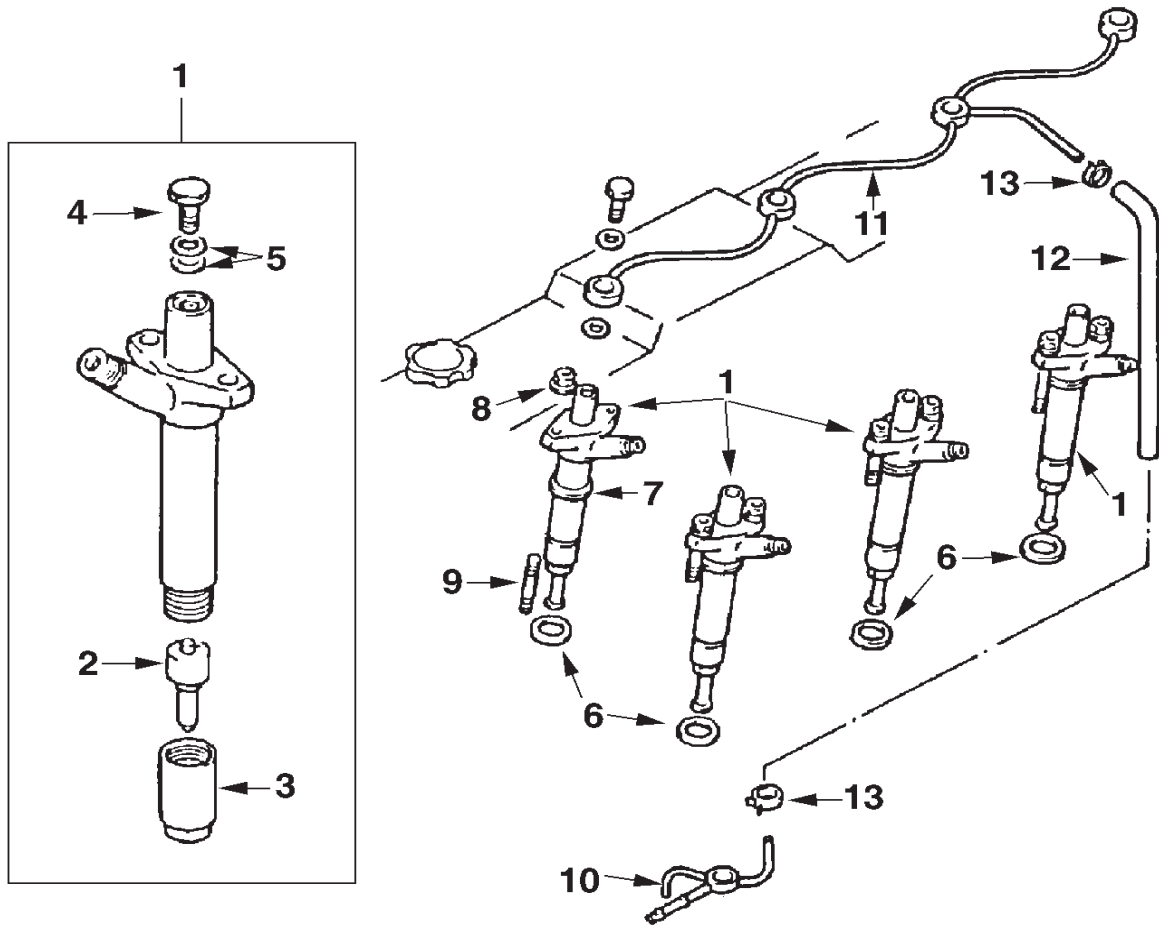

P984 04-01: 2201

KEY	PART NUMBER	QTY	DESCRIPTION	SERIAL NUMBER
1	23600-78700-71	4	Injector, Complete (previously #23600-78301-71)	-
2	23620-78700-71	1	Nozzle (marked DLLA144P700 - for injector 23600-78700-71)	-
	23620-78301-71	1	Nozzle (marked DLLA150P602 - for injector 23600-78301-71)	-
3	23624-58010	1	Nozzle Retaining Nut	-
4	23625-58230	4	Banjo Bolt	-
5	90201-08106	8	Washer	-
6	11176-56020	4	Injection Nozzle Seat	-
7	90430-18014	4	Gasket	-
8	90179-08061	8	Nut	-
9	90116-08234	8	Stud	-
10	23764-78302-71	1	Banjo Union - Fuel Return	-
11	23760-78300-71	1	Fuel Return Pipe Assembly	-
12	18-55403	1	Hose, 3/16" ID x 14"	-
13	96132-30400	2	Hose Clamp	-

Injection Pump & Piping: M984

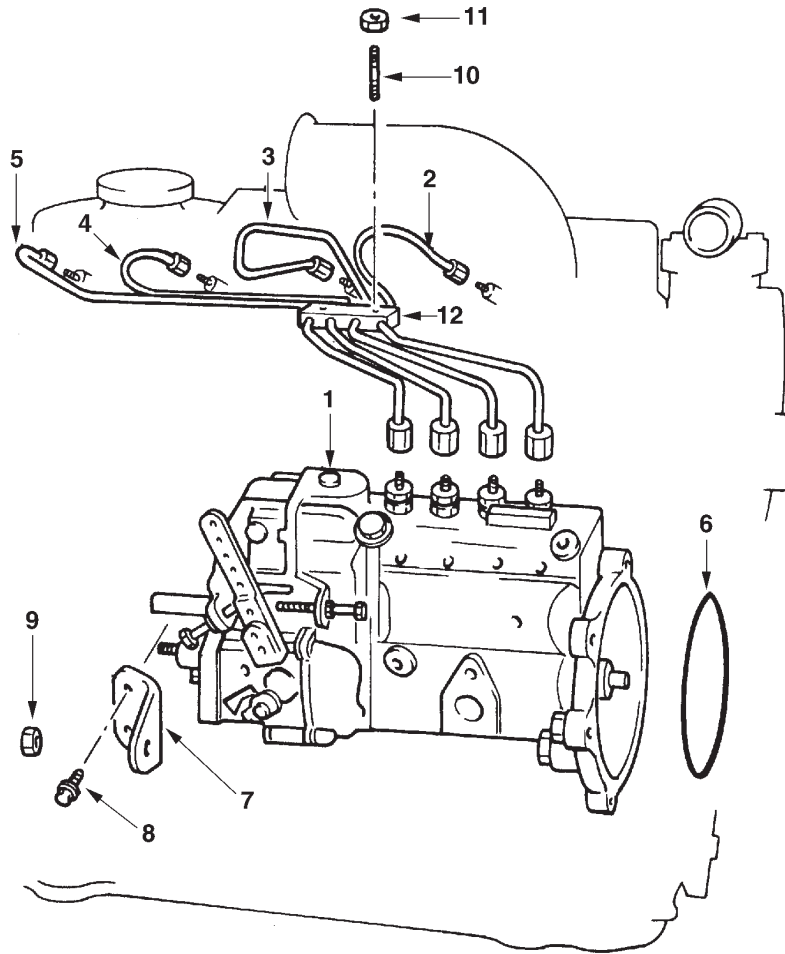

P984 04-02: 2202

KEY	PART NUMBER	QTY	DESCRIPTION	SERIAL NUMBER
1	22100-78705-71	1	Injection Pump Assembly 1800 RPM - Northern Lights	-
2	23701-78301-71	1	Injection Line #1	-
3	23702-78301-71	1	Injection Line #2	-
4	23703-78301-71	1	Injection Line #3	-
5	23704-78301-71	1	Injection Line #4	-
6	90301-99950-71	1	O-Ring	-
7	22811-78301-71	1	Injection Pump Brace	-
8	91651-60820	2	Bolt	-
9	90179-08040	1	Bolt	-
10	92112-60625	2	Stud	-
11	94110-40600	2	Nut	-
12	23741-64020	2	Injection Line Clamp	-
	26-55404	1	Feed Pump Assembly (not shown - see parts detail)	-

Injection Pump, Piping & Throttle: L984

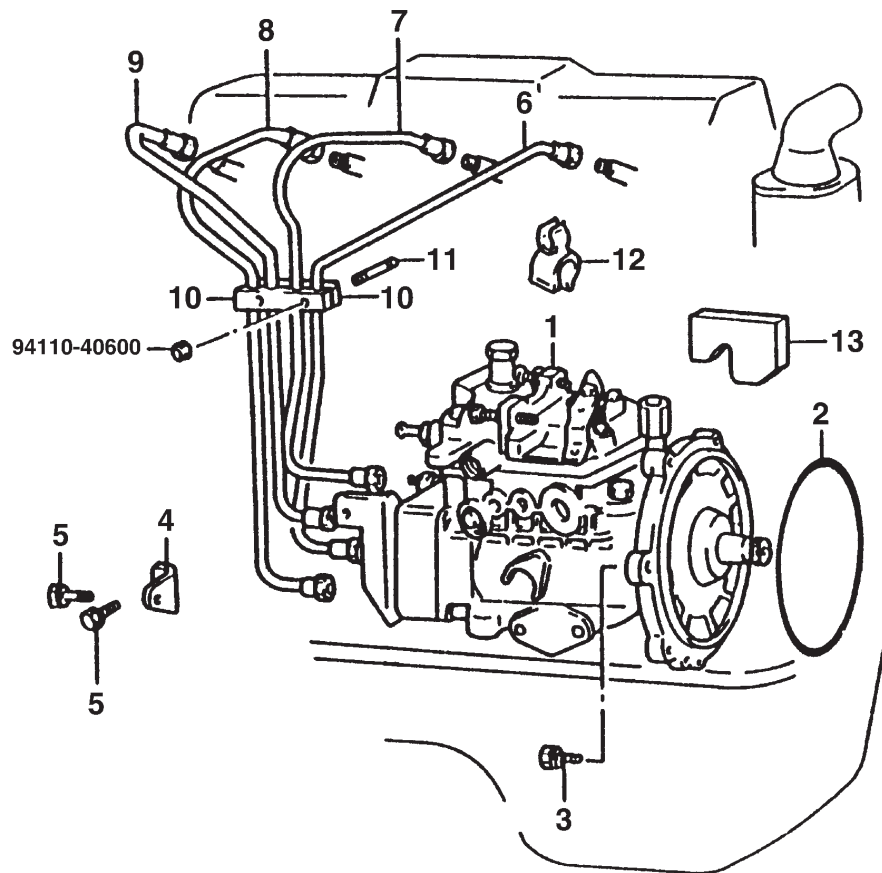

P984 04-03: 2202

KEY	PART NUMBER	QTY	DESCRIPTION	SERIAL NUMBER
1	22100-78719-71	1	Injection Pump Assembly (formerly #22100-78704-71)	-
2	90301-99950-71	1	O-Ring	-
3	91611-61028	6	Bolt	-
4	22811-78300-71	1	Bracket	-
5	91651-60820	2	Bolt	-
6	23701-78300-71	1	Injection Line #1	-
7	23702-78300-71	1	Injection Line #2	-
8	23703-78300-71	1	Injection Line #3	-
9	23704-78300-71	1	Injection Line #4	-
10	23741-64020	2	1/2 Clamp	-
11	92112-60625	2	Stud	-
12	90464-00446	1	Clamp	-
13	12581-78700-71	1	Insulator	-
14	23-95404	1	Bracket, Cable Clamp Mtg. (not shown)	-
15	23-91001	1	Cable Clamp (not shown)	-
16	23-91002	1	Clamp Shim (not shown)	-
17	12-54800	2	Capscrew, Hex Head M5 x 0.8 x 14 mm (not shown)	-
18	15-04400	2	Lock Washer, Helical M5 (not shown)	-
19	12-00030	1	Capscrew, Hex Head M6 x 1.0 x 16 mm (not shown)	-
20	15-01132	1	Lock Washer, Helical M6 (not shown)	-
21	23-91003	1	Throttle Pivot (not shown)	-
22	15-00101	1	Flat Washer 1/4 s/s (not shown)	-
23	00-54801	1	Cotter Pin (not shown)	-

Fuel Filter & Piping / Injection Pump & Piping: M984

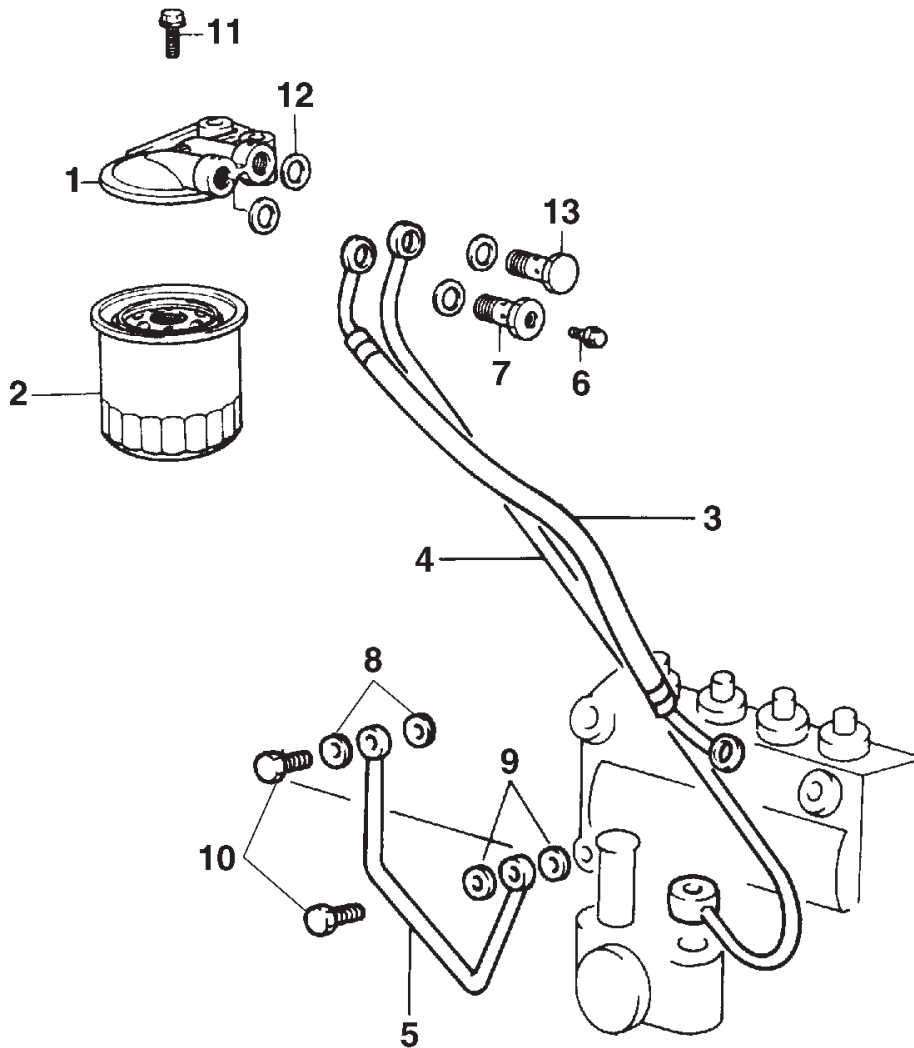

P984 04-04: 1502 / 2302

KEY	PART NUMBER	QTY	DESCRIPTION	SERIAL NUMBER
••	23300-56080	1	Filter Head Assembly with Element	-
1	23311-56070	1	Fuel Filter Base	-
2	24-52020	1	Fuel Filter	-
3	23906-78300-71	1	Hose Assembly	-
4	23801-78300-71	1	Pipe Assembly	-
5	15707-78300-71	1	Oil Supply Line	-
6	47547-12030	1	Vent Plug	-
7	23319-48010	1	Banjo Bolt	-
8	90430-10035	2	Washer	-
9	90430-10025	2	Washer	-
10	07206-30710	2	Banjo Bolt	-
11	91611-61045	2	Bolt	-
12	94712-77121	4	Washer	-
13	90099-18010	1	Banjo Bolt	-

Fuel Filter

Propulsion Engines

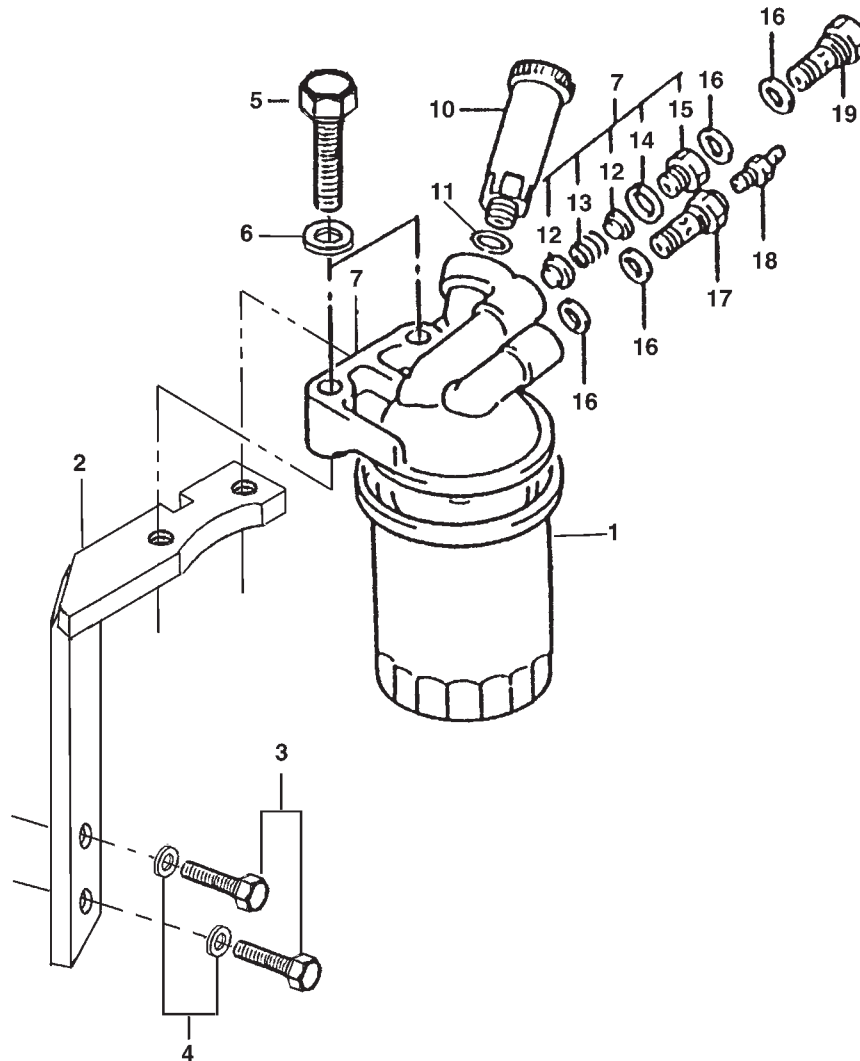

P984 04-04A: 2302

KEY	PART NUMBER	QTY	DESCRIPTION	SERIAL NUMBER
••	23300-78200-71	1	Fuel Filter Assembly w/Primer Pump (includes keys #1, #7, & #10 - #19)	-
1	24-52020	1	Fuel Filter	-
2	23-55406	1	Bracket, Fuel Filter Mtg.	-
3	12-00712	2	Capscrew, Hex Head M8 x 1.25 x 25 mm	-
4	15-00702	2	Lock Washer, Helical M8	-
5	12-00812	2	Capscrew, Hex Head M10 x 1.25 x 40 mm	-
6	15-00805	2	Flat Washer M10	-
7	23301-87315	1	Filter Head Assembly (includes keys #12 - #15)	-
8	27-55402	1	Tube, Fuel Filter Supply (not shown)	-
9	90405-08128	1	Banjo Union (not shown)	-
10	22501-87302	1	Primer Pump	-
11	23344-54020	1	Gasket	-
12	23316-54010	2	Valve Sub-Assembly	-
13	23314-54010	1	Spring	-
14	15318-44010	1	Gasket	-
15	23323-56060	1	Union	-
16	94712-77121	4	Washer	-
17	23319-48010	1	Banjo Bolt	-
18	47547-12030	1	Vent Plug	-
19	90099-18010	1	Banjo Bolt	-

Fuel System

Marine Generator Application

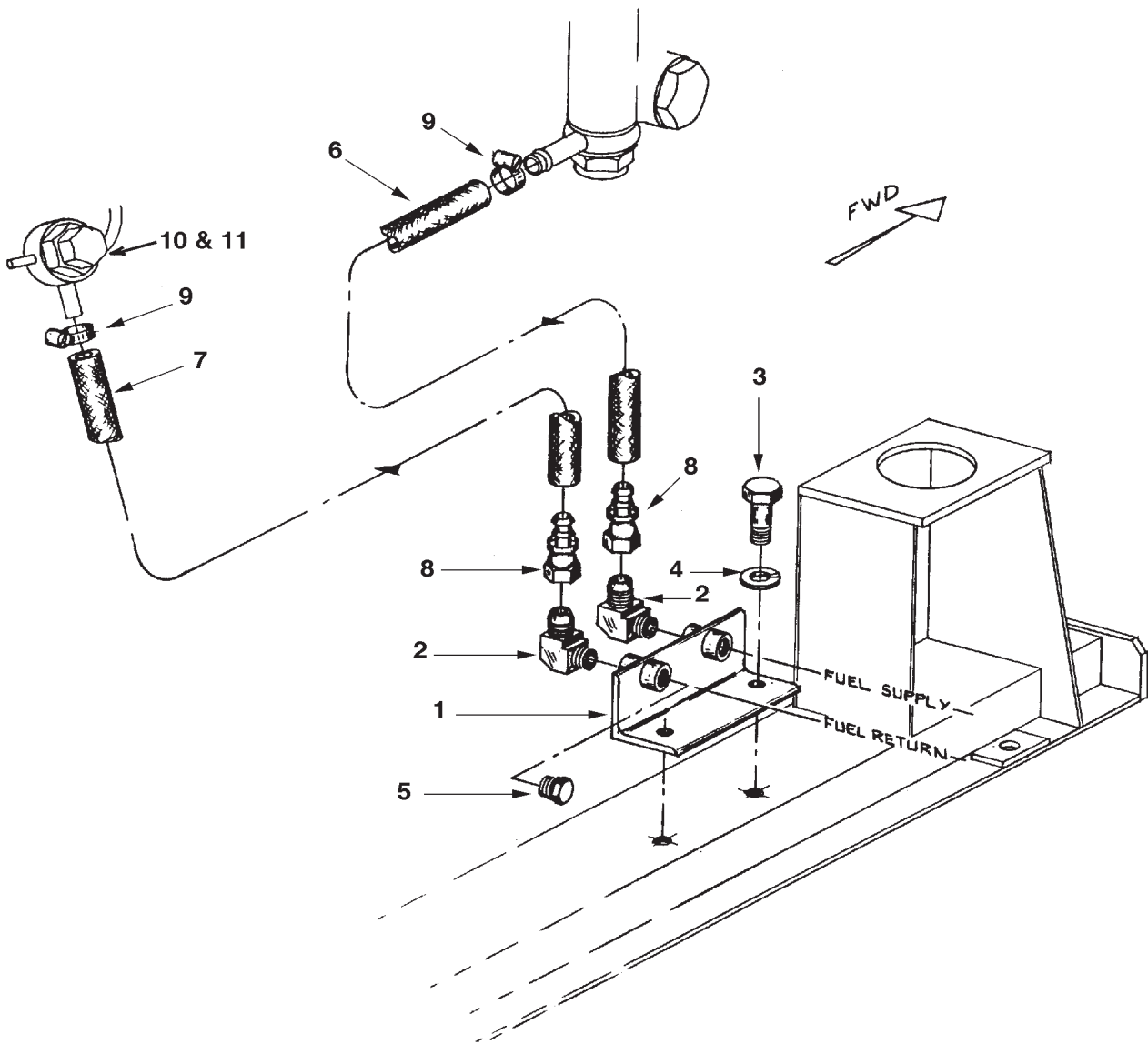

A-4247A / C-2348

KEY	PART NUMBER	QTY	DESCRIPTION	SERIAL NUMBER
1	10-51099	1	Fuel Manifold, 1/4 NPT	-
2	21-52245	2	Male Elbow 90° Brass, 1/4 NPT x 5/16-45T	-
3	12-00111	2	Capscrew, Hex Head 1/4 - 20 x 3/4"	-
4	15-00102	2	Lock Washer, Helical 1/4"	-
5	21-31624	2	Plug, Brass Hex Head 1/4 NPT (for shipping)	-
6	18-52103	1	Hose, 5/16" ID x 15"	-
7	18-51903	1	Hose, 5/16" ID x 20"	-
8	21-71056	2	Swivel Connector, 5/16HB x 5/16-45T	-
9	19-55400	2	Speedy Clamp, Size "E" (can use 19-00002)	-
10	22160-76002-71	1	Banjo Bolt with Check Valve	-
11	07005-01412	2	Sealing Washer	-

Fuel System - U.S. Coast Guard Approved

Marine Generator Application

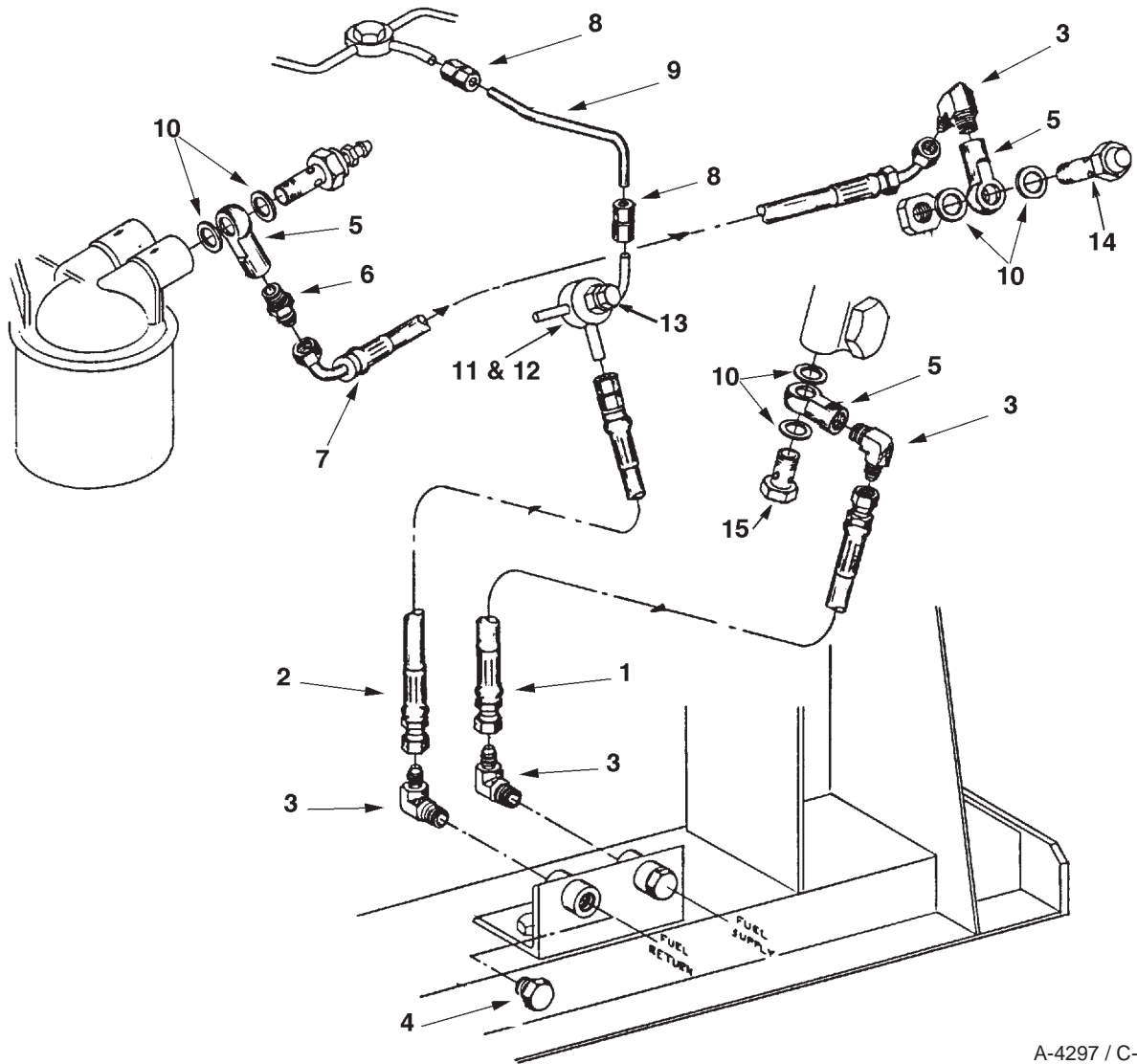

A-4297 / C-2362A

KEY	PART NUMBER	QTY	DESCRIPTION	SERIAL NUMBER
1	18-52212	1	Hose Assembly 1/4" ID x 14"	-
2	18-55402	1	Hose Assembly 1/4" ID x 20"	-
3	21-71049	4	Male Elbow 90° Steel 1/4 NPT x 1/4-37T	-
4	21-31624	2	Plug 1/4 NPT (for shipping)	-
5	21-52203	3	Banjo Fitting 1/4 NPT	-
6	21-71049	1	Male Elbow 90°, Steel 1/4 NPT x 1/4-37T (formerly #21-74406)*	-
7	18-55407	1	Hose Assembly 1/4" ID x 20" (formerly #18-55401)*	-
8	21-53204	2	Compression Hex Union - 3/16	-
9	27-55401	1	Tube 3/16" OD	-
10	94712-77121	6	Washer (can use 07005-01412)	-
11	21-55406	1	Connector Assembly with Nuts & Ferrules	-
12	07005-01212	2	Sealing Washer	-
13	22160-76002-71	1	Banjo Bolt with Check Valve	-
14	80099-76032-71	1	Banjo Bolt	-
15	092223-0070	1	Banjo Bolt	-

*NOTE: Items #6 and #7 required when replacing earlier hose and fitting.

Fuel Feed Pump Assembly

Marine Generator Application

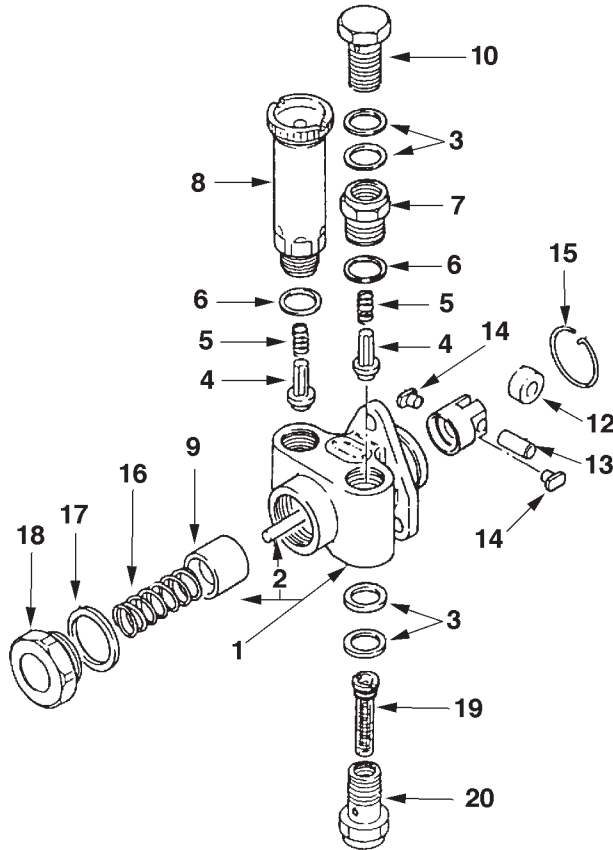

P984 04-08: PH0091

KEY	PART NUMBER	QTY	DESCRIPTION	SERIAL NUMBER
••	26-55404	1	Feed Pump Assembly (includes keys #1 - #20)	-
•	192290-0060	1	Overhaul Kit	-
1	092120-0340	1	Housing (includes key #2)	-
2	092168-0010	1	Push Rod	-
3	090222-0070	4	Washer	-
4	092121-0011	2	Check Valve	-
5	092124-0010	2	Spring	-
6	092125-0010	2	Gasket	-
7	092127-0010	1	Valve Support	-
8	130516014	1	Primer Pump	-
9	092171-0011	1	Piston	-
10	949180-0310	1	Banjo Bolt	-
11	092174-0030	1	Tappet (not shown)	-
12	092176-0010	1	Roller	-
13	092178-0010	1	Pin	-
14	092179-0050	2	Block	-
15	949072-0940	1	Snap Ring	-
16	092182-0030	1	Spring	-
17	949018-1240	1	Washer	-
18	092184-0021	1	Plug	-
19	092220-0040	1	Screen	-
20	092223-0070	1	Banjo Bolt	-
21	131296303	1	O-Ring (for Pump Mounting - not shown)	-

Notes

Engine Electrical - 12 Volt Luger Standard Ground

Propulsion Engine Applications

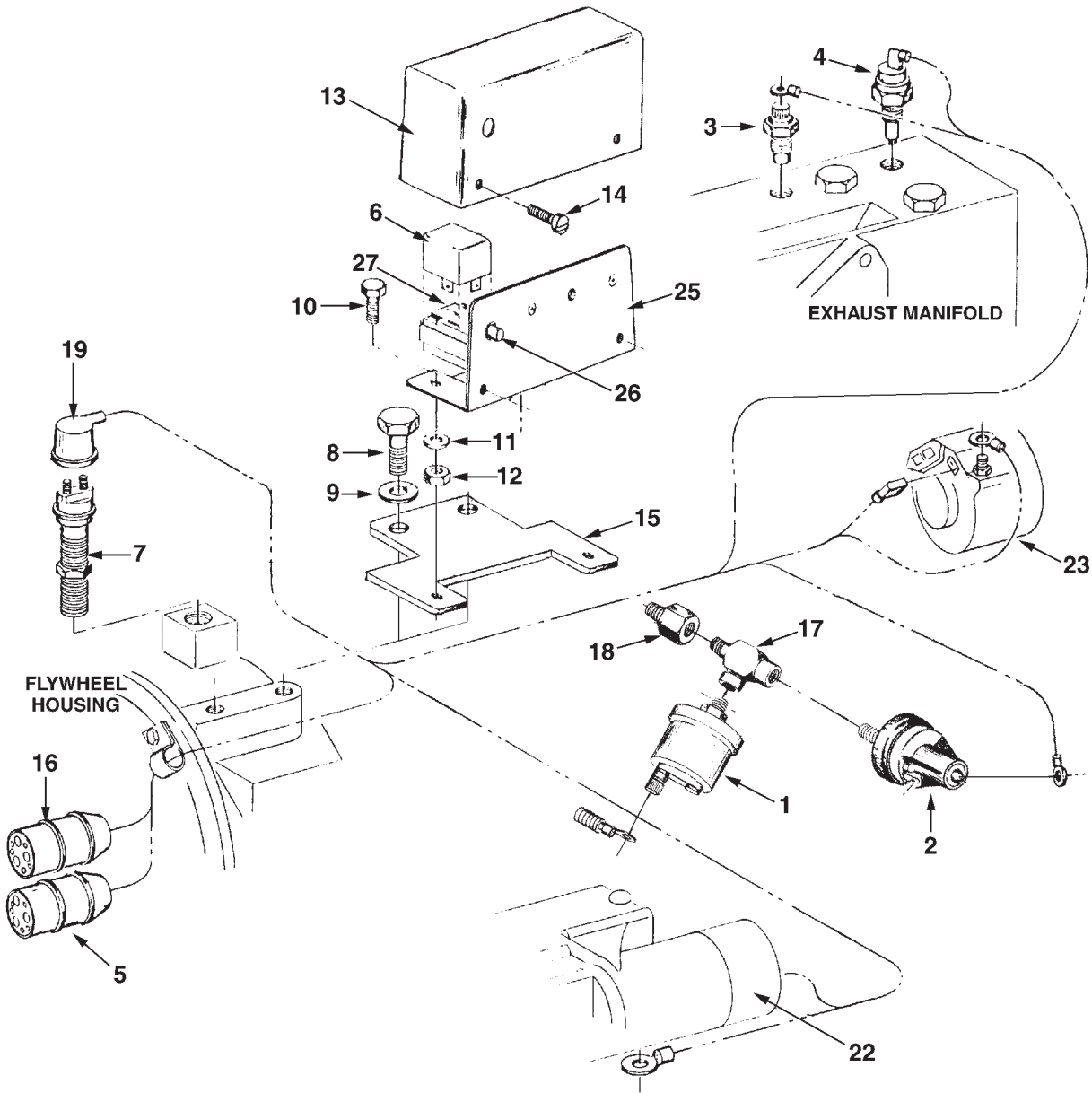

A-7714 / C-2452

Engine Electrical - 12 Volt Luger Standard Ground

Propulsion Engine Applications

KEY	PART NUMBER	QTY	DESCRIPTION	SERIAL NUMBER
1	22-41016	**	Oil Pressure Sender, Single Station 0-80 PSI	-
	22-44871	**	Oil Pressure Sender, Single Station 0-150 PSI	-
2	22-40233	1	Oil Pressure Switch	-
3	22-42055	1	Temperature Sender, Single Station 250°F	-
4	22-41025	1	Temperature Switch	-
5	22-45408	1	Wire Harness with Circuit Breaker (see parts detail)	-
6	22-42047	2	12 Volt Relay	-
7	22-44812	1	Magnetic Tachometer Pick-Up	-
8	12-00711	2	Capscrew, Hex Head M12 x 1.25 x 20 mm*	-
9	15-00701	2	Lock Washer, M12*	-
10	12-00030	2	Capscrew, Hex Head M6 x 1.0 x 15 mm	-
11	15-01132	2	Lock Washer, M6	-
12	14-01131	2	Hex Nut, M6 x 1.0	-
13	00-44801	1	Relay Bracket Cover	-
14	12-00094	2	Machine Screw, #10-32 x 3/8" S/S	-
15	23-45419	1	Relay Mounting Bracket* (formerly #23-44806)	-
16	19-71031	1	Adelle Clamp	-
17	21-05400	1	Street Tee, Steel 1/8 NPT	-
18	21-00139	1	Female Connector, Steel 1/8 NPT x 1/8 BSPT	-
19	22-44813	1	Tachometer Pick-Up Boot	-
20	22-41002	1	Extension Harness, 20 ft.	-
21	22-95455	1	Main Instrument Panel, 12 Volt (see detail)	-
22	28100-78502-71	1	12 Volt Starter (see detail)	-
23	27060-78301-71	1	Alternator 12 Volt 40 Amp (see mounting detail)	-
24	26-55409	1	Fuel Solenoid, 12 Volt (not shown)	-
			*Replaces earlier top mounted bracket and fasteners	
			**As required	

Engine Electrical 12 Volt & 24 Volt Standard Ground

Generator Set Applications

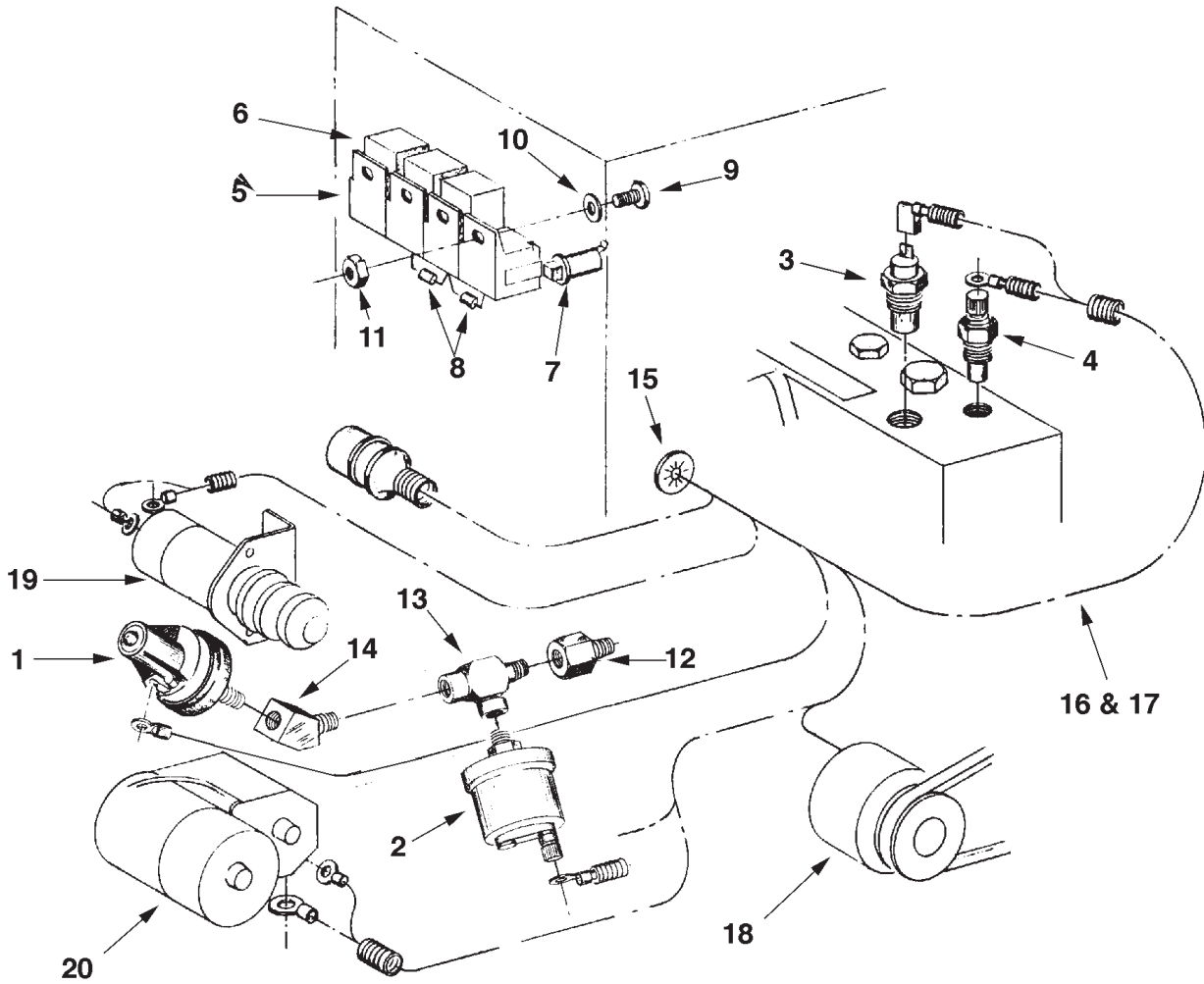

A-4202 / C-2451A

Engine Electrical 12 Volt & 24 Volt Standard Ground

Generator Set Applications

KEY	PART NUMBER	QTY	DESCRIPTION	SERIAL NUMBER
••	22-70083	1	Dual Station Relay Board, 12 Volt* (includes keys #5 - #11 – see parts detail, formerly #22-70007)	-
••	22-70084	1	Dual Station Relay Board, 24 Volt* (includes keys #5 - #11 – see parts detail, formerly #22-70018)	-
1	22-40233	1	Oil Pressure Switch	-
2	22-41016	**	Oil Pressure Sender - Single Station 0-80 PSI } Early Production Oil Pressure Sender - Dual Station 0-80 PSI } Oil Pressure Sender - Single Station 0-150 PSI } Current Oil Pressure Sender - Dual Station 0-150 PSI } Production	-
	22-71016	**		-
	22-44871	**		-
	22-44872	**		-
3	22-41025	1	Temperature Switch	-
4	22-42055	1	Temperature Sender - Single Station	-
	22-71026	1	Temperature Sender - Dual Station	-
	21-51099	1	Bushing 3/8 NPT x 1/4 NPT (use with dual station sender)	-
5	22-40391	3	Relay Base ***	-
	22-40393	3	Clip	-
6	22-42047	3	Relay, 12 Volt	-
	22-40085	3	Relay, 24 Volt	-
7	22-40018	1	Circuit Breaker, 15 Amp (units with relay board assemblies)	-
	22-42043	1	Circuit Breaker, 15 Amp (units with PX-K generators)	-
8	22-41060	2	Diode	-
9	12-00015	3	Machine Screw, #10 - 32 x 3/8"	-
10	15-00032	3	Flat Washer, #10	-
11	14-00006	3	Hex Nut, Nylock #10-32	-
12	21-00139	1	Female Adapter 1/8 BSPT x 1/8 NPT	-
13	21-05400	1	Street Tee 1/8 NPT	-
14	21-00004	1	Street Elbow 45° 1/8 NPT	-
15	00-41015	1	Universal Bushing	-
16	22-45409	1	Wire Harness (units with 224, 360, and 361 frame generators)	-
	22-45407	1	Wire Harness (units with PX-K generators require #5 base & clip if equipped with early relay base without clip)	-
17	22-40928	**	Harness Extension 10 ft.	-
	22-40930	1	Harness Extension 20 ft. (standard equipment)	-
	22-40931	**	Harness Extension 40 ft.	-
	22-40932	1	Y-Harness (for multiple panels)	-
18	27060-78305-71	1	Alternator, 12 Volt 40 Amp (see mounting & parts detail)	-
	22-40278	1	Alternator, 24 Volt 40 Amp	-
19	22-42054	1	Stop Solenoid 12 Volt (see mounting detail)	-
	22-40007	1	Stop Solenoid 24 Volt (see mounting detail)	-
20	28100-78502-71	1	Starter 12 Volt (see parts detail)	-
	28100-78501-71	1	Starter 24 Volt	-
			*Note 1: Relay board assemblies used on units with 224, 360, and 361 frame generators.	
			**As required	
			***Note 2: Relay base without retainer clip replaced by kit 22-40395 (includes base, clip, & terminals). Use if not replacing wire harness.	

Engine Electrical 12 Volt & 24 Volt Isolated Ground

Generator Set Applications

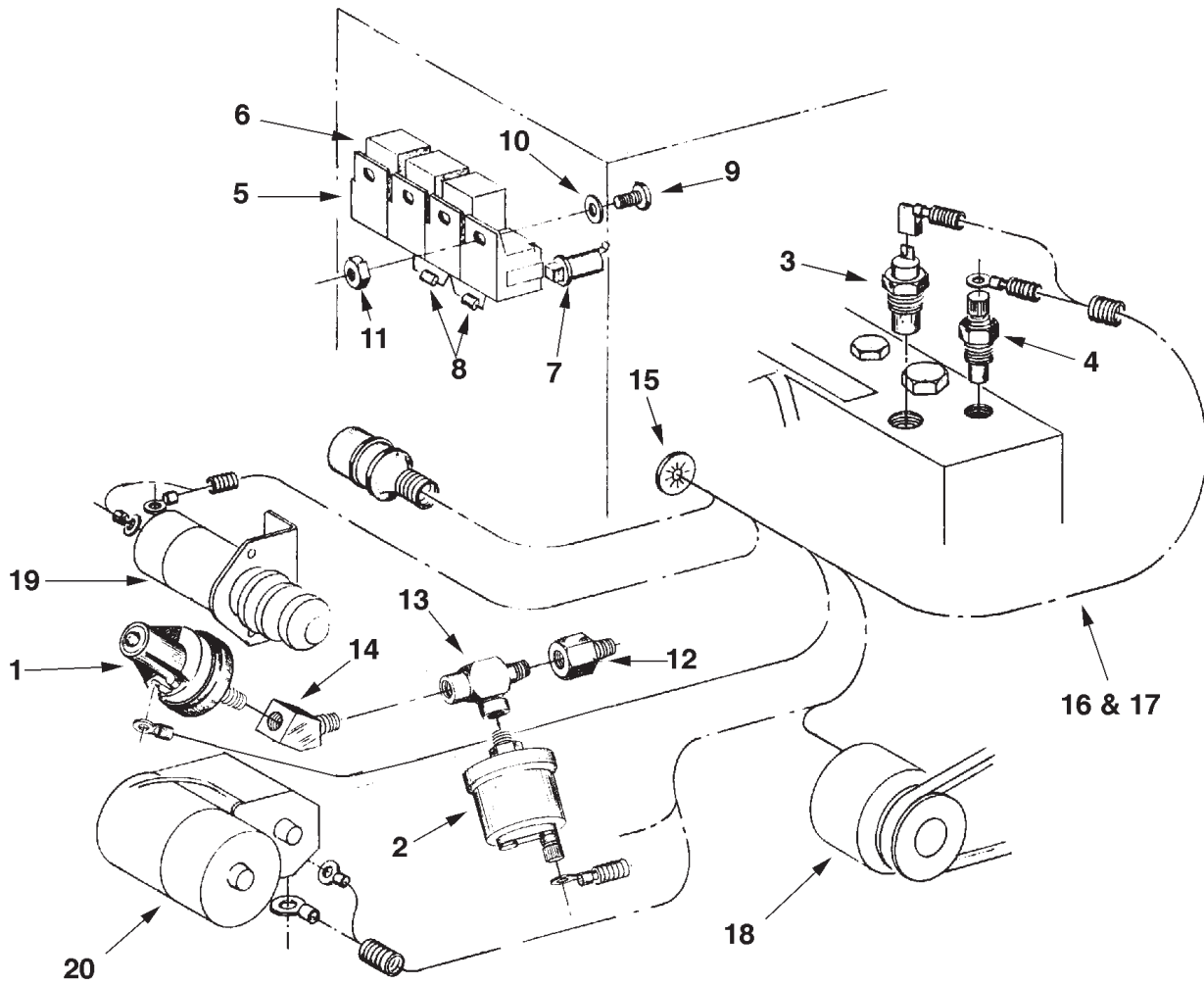

P984 05-04

Engine Electrical 12 Volt & 24 Volt Isolated Ground

Generator Set Applications

KEY	PART NUMBER	QTY	DESCRIPTION	SERIAL NUMBER
••	22-70083	1	Relay Board 12 Volt* (includes keys #5 - #11 – see parts detail, formerly #22-70007)	-
••	22-70084	1	Relay Board 24 Volt* (includes keys #5 - #11 – see parts detail, formerly #22-70018)	-
1	22-40236	1	Oil Pressure Switch	-
2	22-42803	**	Oil Pressure Sender - Single Station 0-80 PSI	-
	22-74803	**	Oil Pressure Sender - Dual Station 0-80 PSI	-
	22-40201	**	Oil Pressure Sender - Single Station 0-150 PSI	-
	22-40108	**	Oil Pressure Sender - Dual Station 0-150 PSI	-
3	22-40906	1	Temperature Switch	-
4	22-44810	1	Temperature Sender - Single Station 3/8 NPT	-
	22-74802	1	Temperature Sender - Dual Station 1/4 NPT	-
	21-51099	1	Bushing 3/8 NPT x 1/4 NPT (use with dual station sender)	-
5	22-40391	3	Relay Base ***	-
	22-40393	3	Clip	-
6	22-42047	3	Relay, 12 Volt	-
	22-40085	3	Relay, 24 Volt	-
7	22-40018	1	Circuit Breaker, 15 Amp (units with relay board assemblies)	-
	22-42043	1	Circuit Breaker, 15 Amp (units with PX-K generators)	-
8	22-41060	2	Diode	-
9	12-00015	3	Machine Screw, #10 - 32 x 3/8"	-
10	15-00032	3	Flat Washer, #10	-
11	14-00006	3	Hex Nut, Nylock #10-32	-
12	21-00139	1	Female Adapter 1/8 BSPT x 1/8 NPT	-
13	21-05400	1	Street Tee 1/8 NPT	-
14	21-00004	1	Street Elbow 45° 1/8 NPT	-
15	00-41015	1	Universal Bushing	-
16	22-45409	1	Wire Harness (units with 224, 360, and 361 frame generators)	-
	22-45407	1	Wire Harness (units with PX-K generators - require #5 base & clip if equipped with early relay base without clip)	-
	22-45404	1	Wire Harness Ground Circuit Addition	-
17	22-40928	**	Harness Extension 10 ft.	-
	22-40930	1	Harness Extension 20 ft. (standard equipment)	-
	22-40931	**	Harness Extension 40 ft.	-
	22-40932	1	Y-Harness (for multiple panels)	-
18	22-45406	1	Alternator, 12 Volt 40 Amp (see mounting & parts detail)	-
	22-71052	1	Alternator, 24 Volt 35 Amp (see mounting detail)	-
19	22-42054	1	Stop Solenoid 12 Volt (see mounting detail)	-
	22-40007	1	Stop Solenoid 24 Volt (see mounting detail)	-
20	22-45403	1	Starter 12 Volt (see parts detail)	-
	22-45402	1	Starter 24 Volt	-
			* Note 1: Relay board assemblies used on units with 224, 360, and 361 frame generators.	
			** As required	
			***Note 2: Relay base without retainer clip replaced by kit 22-40395 (includes base, clip, & terminals). Use if not replacing wire harness.	

Dual Station Relay Board

12 Volt and 24 Volt

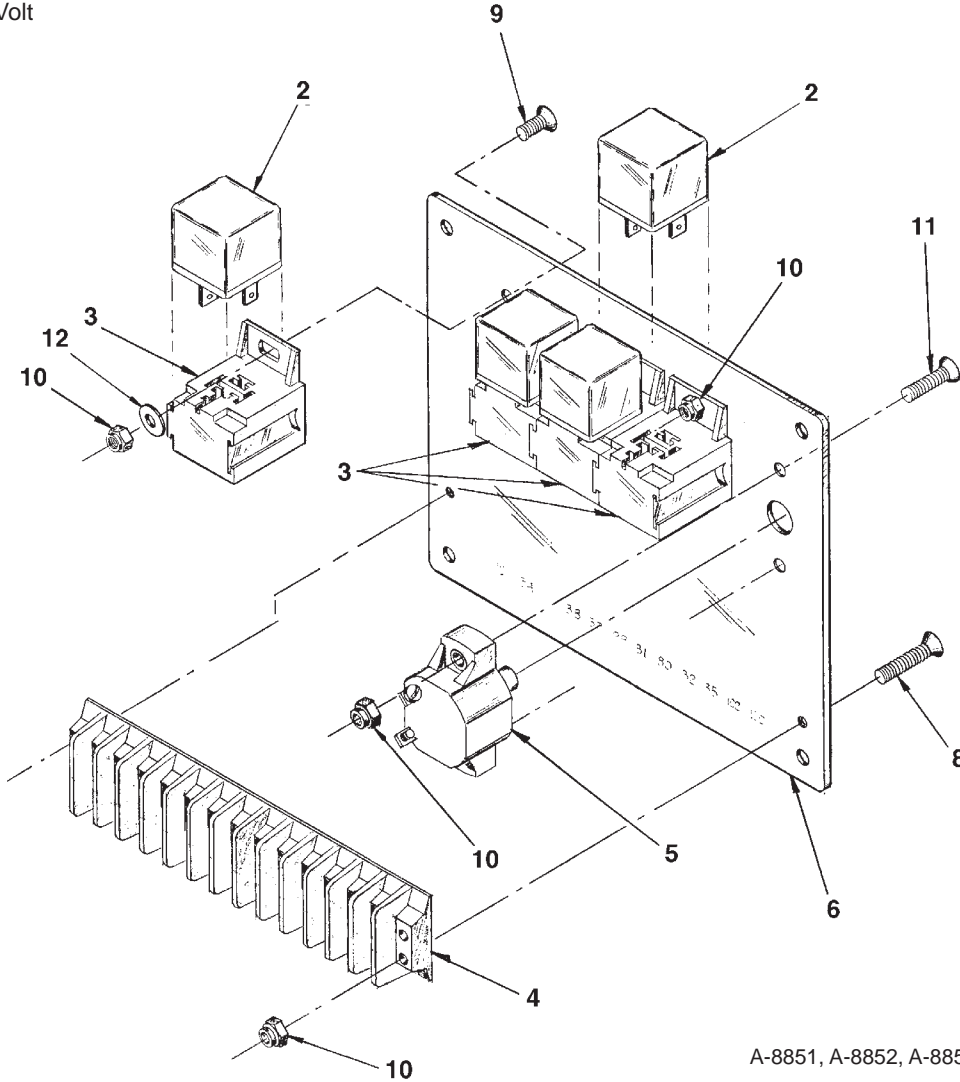

A-8851, A-8852, A-8854, A-8855 / C-2041

KEY	PART NUMBER	QTY	DESCRIPTION	SERIAL NUMBER
••	22-70083	1	12 Volt Relay Logic Board, Manual Start (Includes all keys)	-
••	22-70084	1	24 Volt Relay Logic Board, Manual Start (Includes all keys)	-
••	22-70086	1	12 Volt Relay Logic Board, Autostart (Includes all keys)	-
••	22-70087	1	24 Volt Relay Logic Board, Autostart (Includes all keys)	-
1	22-41060	2	6 Amp Diode (not shown)	-
2	22-42047	4	Relay 12 Volt SPDT	-
	22-40085	4	Relay 24 Volt SPDT	-
3	22-40391	4	Relay Base	-
	22-40393	4	Clip, Terminal Retaining (not shown)	-
4	22-40193	1	12 Connection Terminal Board, 600 VAC	-
5	22-40018	1	10 Amp Circuit Breaker	-
6	28-40001	1	Relay board Mounting Plate	-
7	22-40393	4	Terminal Retainer Clip (not shown)	-
8	12-00083	2	Machine Screw #8 - 32 x 3/4" Flat Head Countersunk	-
9	12-00082	4	Machine Screw #10 - 32 x 3/8" Flat Head Countersunk	-
10	14-00003	4	Hex Nut, Nylock #8 - 32	-
11	12-00089	2	Machine Screw #8 - 32 x 7/8"	-
12	15-00001	4	Flat Washer #8	-
13	22-40347	1	Wire Harness, Manual Start	-
	22-40392	1	Wire Harness, Autostart	-
			} Not shown	

Wire Harness Circuit Breaker & Relay Assembly - 12 & 24 Volt

Propulsion Units

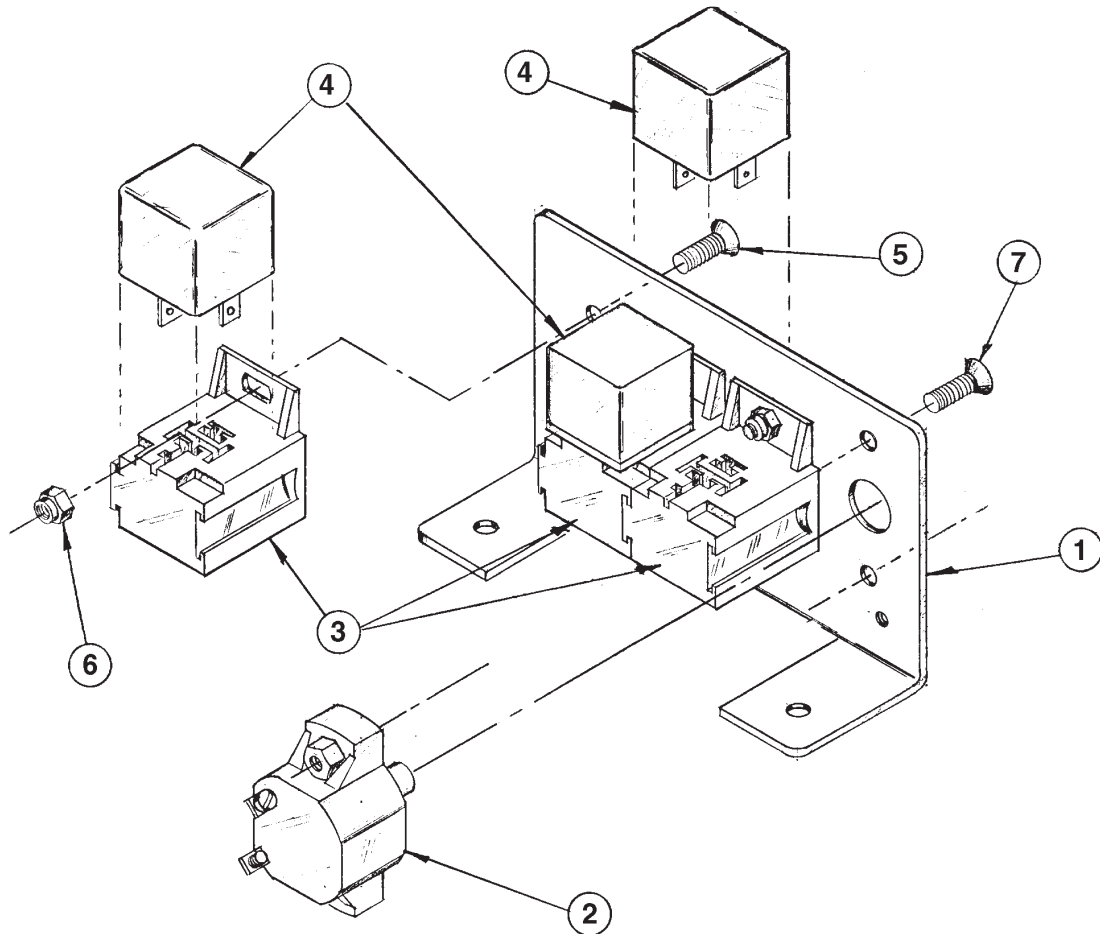

A-4404 / B-3139

KEY	PART NUMBER	QTY	DESCRIPTION	SERIAL NUMBER
••	22-45408	1	Wire Harness Assembly 2 Relay (includes keys #1 - #3 & #6 - #8)	-
1	23-40010	1	Bracket	-
2	22-41070	1	Circuit Breaker 40 Amp	-
3	22-40391	2	Relay Base*	-
	22-40393	2	Clip, Terminal Retaining	-
4	22-40085	2	Relay, 24 Volt (Start and Stop)	-
	22-42047	2	Relay, 12 Volt (Start and Stop)	-
5	12-03010	**	Machine Screw #10-32 x 3/8"	-
6	14-00001	**	Hex Nut #10-32	-
7	12-03011	2	Machine Screw #10-32 x 3/4"	-
			**As required	
			*Note: Relay base without retainer clip replaced by Kit 22-40395 (includes base, clip, & terminals). Use if not replacing wire harness.	

Stop Solenoid & Mounting

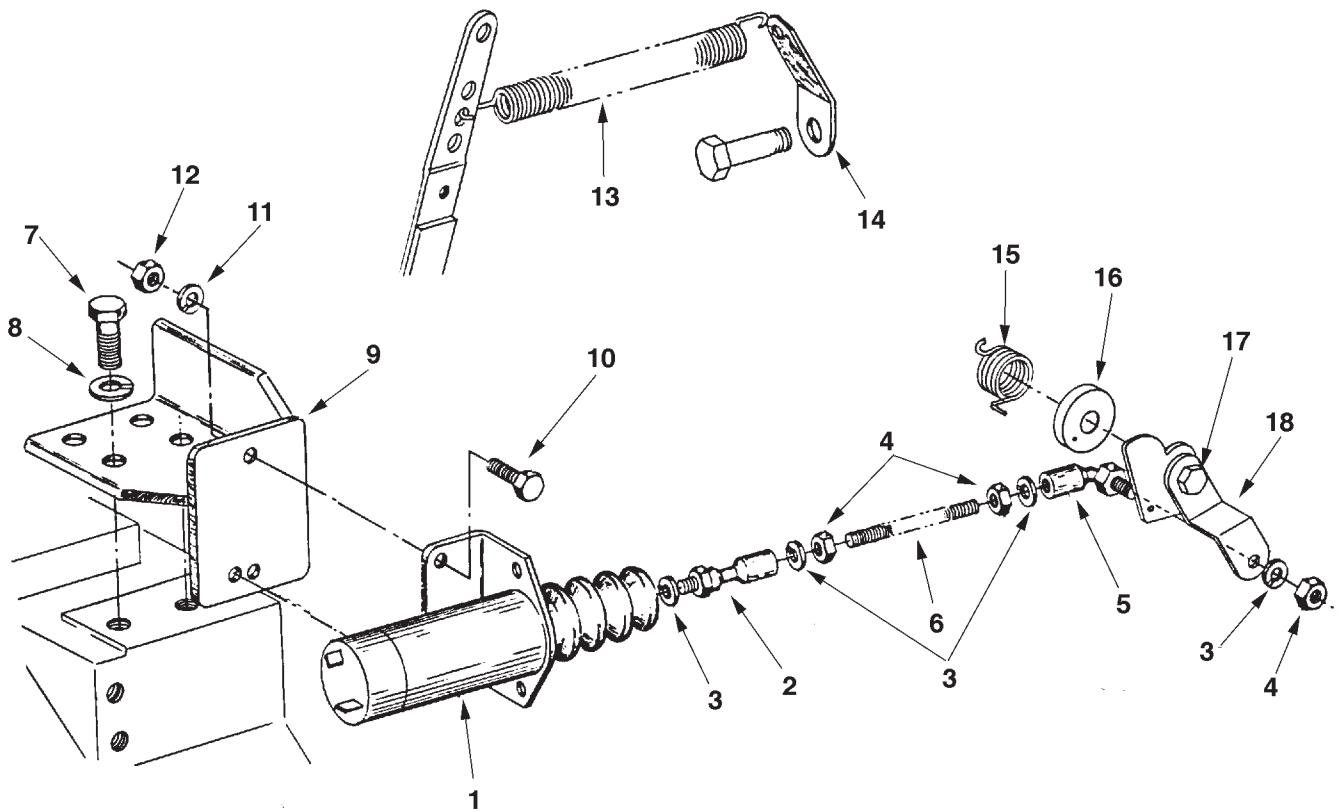

A-4667 / C-2450

KEY	PART NUMBER	QTY	DESCRIPTION	SERIAL NUMBER
1	22-42054	1	Stop Solenoid 12 Volt	-
	22-40007	1	Stop Solenoid 24 Volt with Integral Stud	-
2	00-42501	1	Straight Ball Joint 1/4 - 28	-
3	15-00018	**	Lock Washer, Helical 1/4 High Collar	-
4	14-00121	**	Hex Nut, Steel 1/4 - 28	-
5	00-42502	1	Ball Joint, 90° 1/4 - 28	-
6	13-55401	1	Rod, All Thread 1/4 - 28 x 8" (12 Volt Solenoid)	-
	13-55403	1	Rod, All Thread 1/4 - 38 x 6-3/8" (24 Volt Solenoid)	-
7	12-00712	2	Capscrew, Hex Head M8 x 1.25 x 20 mm	-
8	15-00702	2	Lock Washer, Helical M8	-
9	23-45402	1	Mounting Bracket	-
10	12-00030	2	Capscrew, Hex Head M6 x 1.0 x 16 mm	-
11	15-01132	2	Lock Washer, Helical M6	-
12	14-01131	2	Hex Nut, Steel M6 x 1.0 x 16 mm	-
13	22-55401	1	Throttle Spring	-
14	23-55403	1	Tensioning Spring Bracket	-
15	00-95402	1	Lever Return Spring	-
16	26-55001	1	Spring Cover	-
17	011140616	1	Capscrew w/washer M6 x 1.0 x 15 mm	-
18		1	Stop Lever	-
19	14-00011	1	Hex Nut X-L 1/4-28 x 7/8 (24 Volt Solenoid - not shown)*	-
<p>* Note: Item #19 installs on 24 Volt Solenoid Plunger Stud, coupling together with Swivel #2.</p> <p>**As required</p>				

Alternator Mounting

12 Volt / 40 Amp - Standard or Isolated Ground

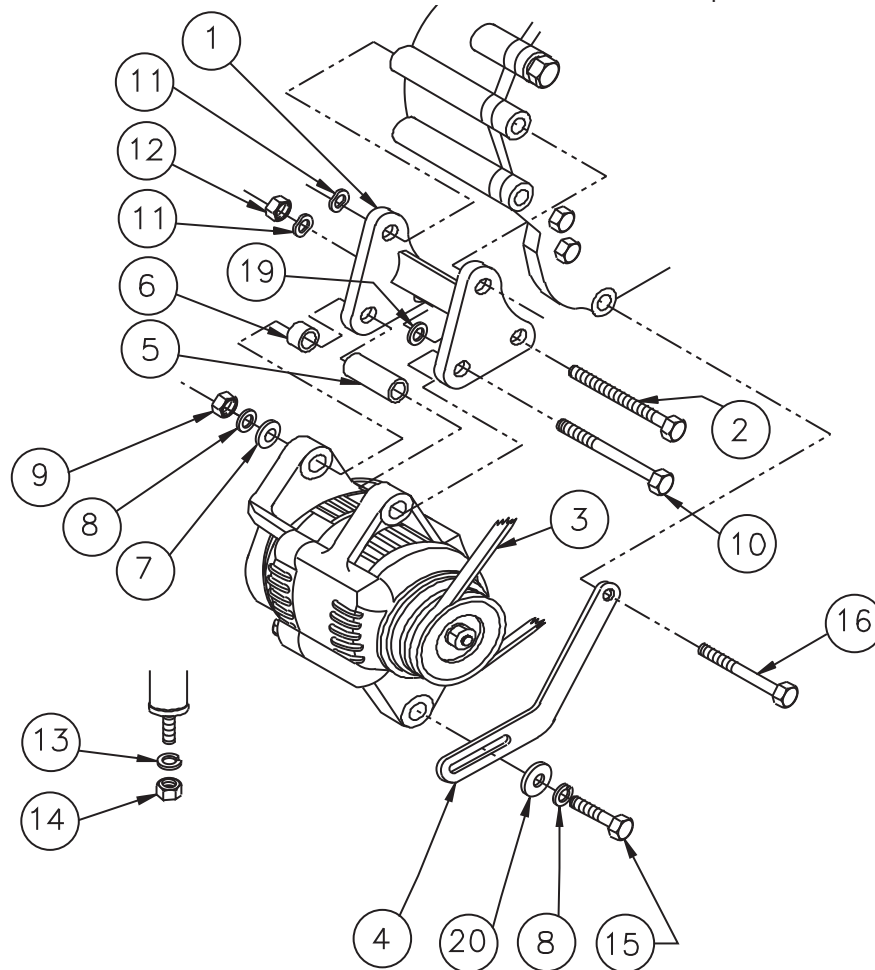

A-4243F / C-2346F

KEY	PART NUMBER	QTY	DESCRIPTION	SERIAL NUMBER
1	23-45401	2	Alternator Mounting Bracket (without PTO)	-
	23-45409	2	Alternator Mounting Bracket (with PTO)	-
2	12-50051	1	Capscrew, Hex Head M10 x 1.25 x 90 mm (full thread)	-
3	40-05403	1	Drive Belt (without PTO)	-
	40-05405	1	Drive Belt (with PTO)	-
4	23-45403	1	Tensioning Arm	-
5	21-45401	1	Spacer	-
6	21-45402	1	Spacer	-
7	15-00701	1	Flat Washer, M8	-
8	15-00702	2	Lock Washer, Helical M8	-
9	14-00711	1	Hex Nut, Steel M8 x 1.25	-
10	12-00731	1	Capscrew, Hex Head M8 x 1.25 x 120 mm	-
11	15-00804	2	Wave Washer, M10	-
12	14-00814	2	Hex Nut, Steel M10 x 1.25	-
13	15-01132	1	Lock Washer, Helical M6	-
14	14-01131	1	Hex Nut, Steel M6 x 1.0	-
15	12-00712	1	Capscrew, Hex Head M8 x 1.25 x 25 mm	-
16	12-00803	1	Capscrew, Hex Head M10 x 1.25 x 65 mm	-
19	15-00805	1	Flat Washer M10	-
20	15-00201	1	Stud Washer	-

Alternator and Mounting - 12 Volt / 40 Amp

Propulsion Units

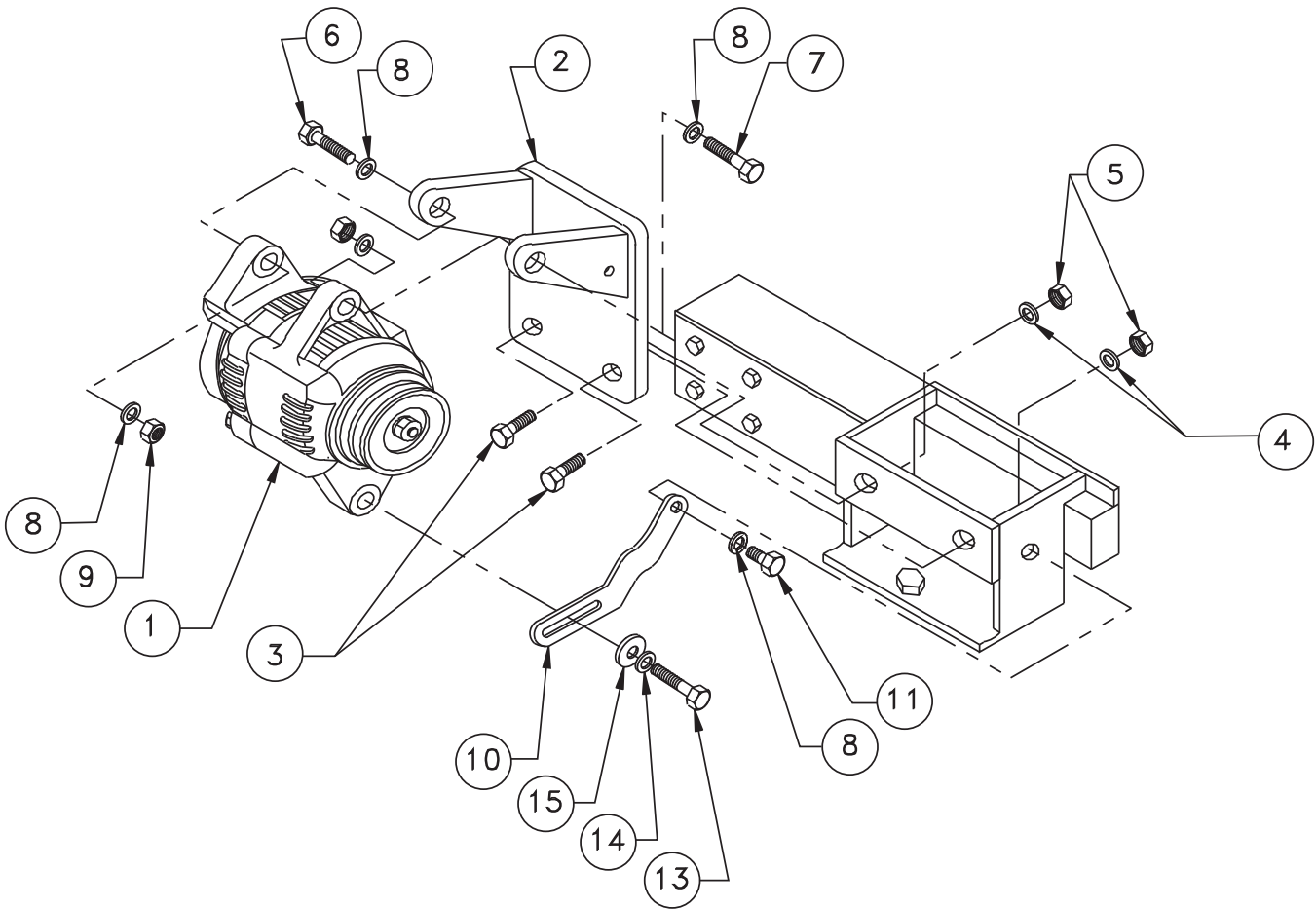

A-7847 / B-6952

KEY	PART NUMBER	QTY	DESCRIPTION	SERIAL NUMBER
1	27060-78301-71	1	Alternator, 12V/40A (see parts detail)	-
2	23-45411	1	Bracket, Alternator Mtg.	-
3	12-00831	2	Capscrew, Hex Head M10 x 1.5 x 25 mm	-
4	15-00805	2	Flat Washer M10	-
5	14-00812	2	Hex Nut, Nylock M10 x 1.5	-
6	12-00714	1	Capscrew, Hex Head M8 x 1.25 x 40 mm	-
7	12-00713	1	Capscrew, Hex Head M8 x 1.25 x 35 mm	-
8	15-00701	4	Flat Washer M8	-
9	14-04802	2	Hex Nut, Nylock M8 x 1.25	-
10	23-45413	1	Tensioning Arm	-
11	12-00805	1	Capscrew, Hex Head M10 x 1.5 x 20 mm	-
12	40-05407	1	Drive Belt (not shown)	-
13	12-00753	1	Capscrew, Hex Head M8 x 1.25 x 30 mm	-
14	15-00702	1	Lock Washer, Helical M8	-
15	15-00201	1	Stud Washer 5/16	-

Alternator - 12 Volt / 40 Amp

Standard Ground

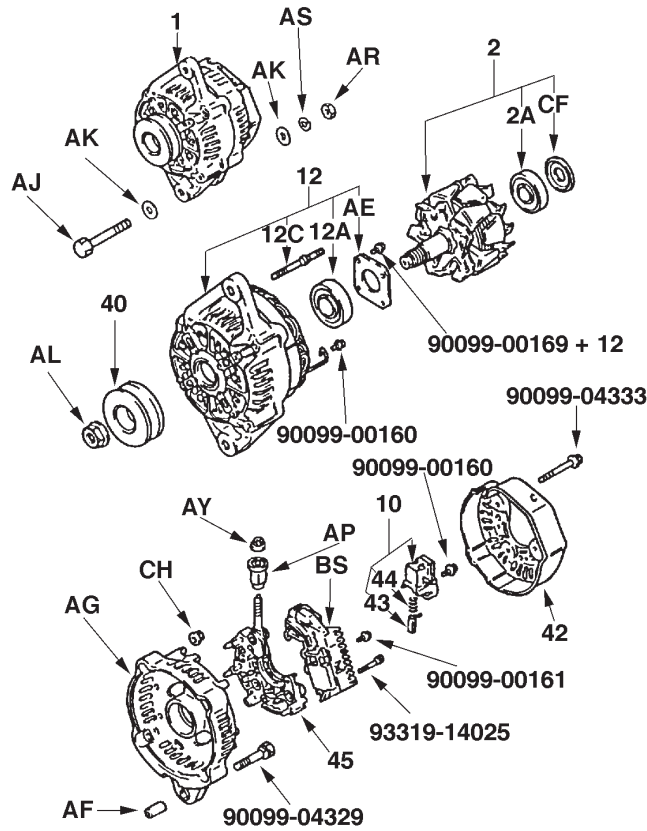

P984 05-11: 1903

KEY	PART NUMBER	QTY	DESCRIPTION	SERIAL NUMBER
1	27060-78301-71	1	Alternator Assembly with Regulator (includes all keys)	-
2	27330-78301-71	1	Alternator Rotor Assembly	-
2A	90099-78001-71	1	Bearing	-
10	27370-63021	1	Alternator Brush Holder Assembly	-
12	27310-78301-71	1	Drive End Frame Assembly	-
12A	90099-78000-71	1	Bearing	-
12C	90099-04330	2	Stud Bolt	-
40	27411-78301-71	1	Alternator Pulley	-
42	27039-78300-71	1	Rear End Cover	-
43	27371-63020	2	Alternator Brush	-
44	27372-63020	2	Brush Spring	-
45	27357-78301-71	1	Holder with Rectifier	-
AE	27312-72120	1	Bearing Retainer Plate	-
AF	27351-78300-71	1	Bushing	-
AG	27359-78300-71	1	Rectifier End Frame	-
AJ	90101-08950-71	1	Hexagon Bolt	-
AK	94611-10800	2	Plate Washer	-
AL	90099-05171	1	Pulley Lock Nut	-
AP	27387-78000-71	1	Insulator	-
AR	94110-40800	1	Nut	-
AS	94512-00800	1	Spring Washer	-
AY	90099-05119	1	Nut	-
BS	27700-78301-71	1	Regulator Assembly	-
CF	27443-63020	1	Bearing Cover	-
CH	90099-05172	2	Nut	-

Alternator Options

Northern Lights Application - Early Production

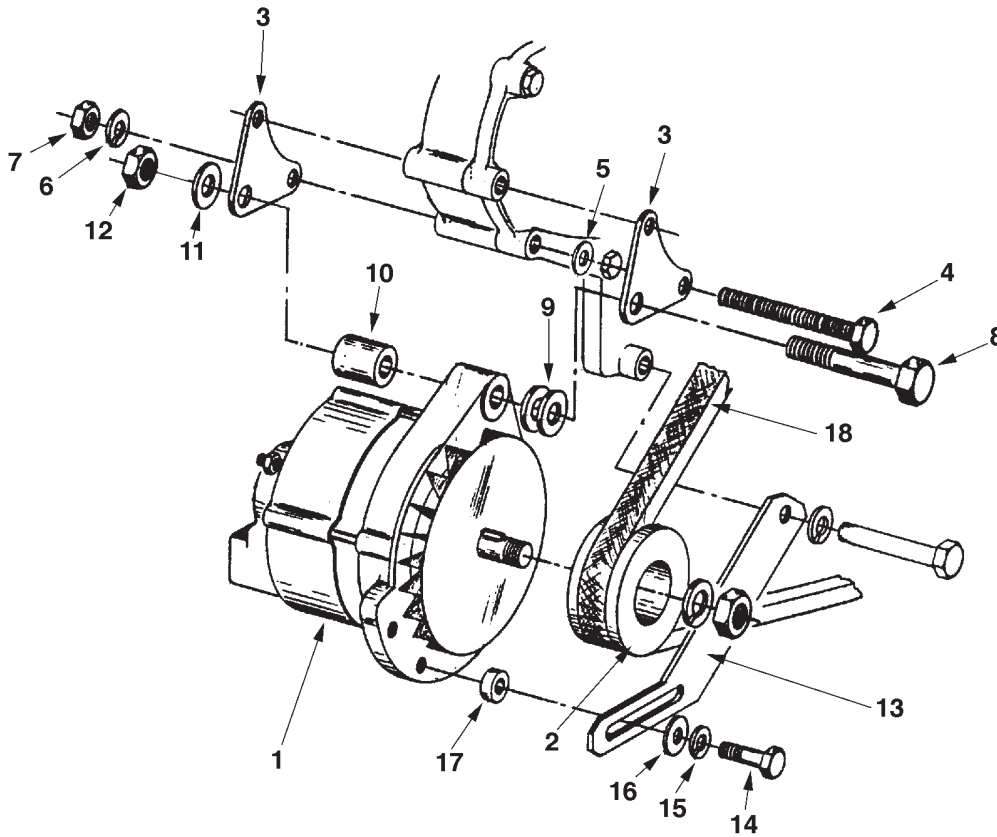

C-2366A

KEY	PART NUMBER	QTY	DESCRIPTION	SERIAL NUMBER
1	22-40332	1	Alternator 12 Volt / 90 Amp	-
	22-40278	1	Alternator 24 Volt / 40 Amp	-
	22-71052	1	Alternator 24 Volt / 35 Amp	-
2	34-42001	1	Pulley 1-A/B x 1-1/2" x 5/8" ID (formerly #34-41000)*	-
3	23-45406	1	Bracket, Alternator Mounting (formerly 2 pieces)	-
4	12-50051	2	Capscrew, Hex Head M10 x 1.25 x 90 mm, All Thread	-
5	15-00805	1	Flat Washer M10	-
6	15-00804	2	Wave Washer M10	-
7	14-00814	2	Hex Nut M10 x 1.25	-
8	12-00500	1	Capscrew, Hex Head 1/2-13 x 4"	-
9	15-00504	2	Flat Washer 1/2 SAE*	-
10	21-41102	1	Spacer*	-
11	15-00504	1	Flat Washer 1/2 SAE	-
12	14-00512	1	Hex Nut, Nylock 1/2-13	-
13	23-42006	1	Tensioning Arm (formerly #23-45403)	-
14	12-00213	1	Capscrew, Hex Head 5/16-18 x 1-1/4"	-
15	15-00202	1	Lock Washer 5/16	-
16	15-00201	1	Stud Washer 5/16	-
17	21-75402	**	Spacer	-
18	40-05403	1	Drive Belt (without PTO)	-
	40-05405	1	Drive Belt (with PTO)	-
19	22-70048	**	Diode Harness (not shown)	-

*Replaces earlier pulley and spacer combination.
Must be used together to maintain correct alignment.
**As required

Alternator Options

Northern Lights Application - Late Production

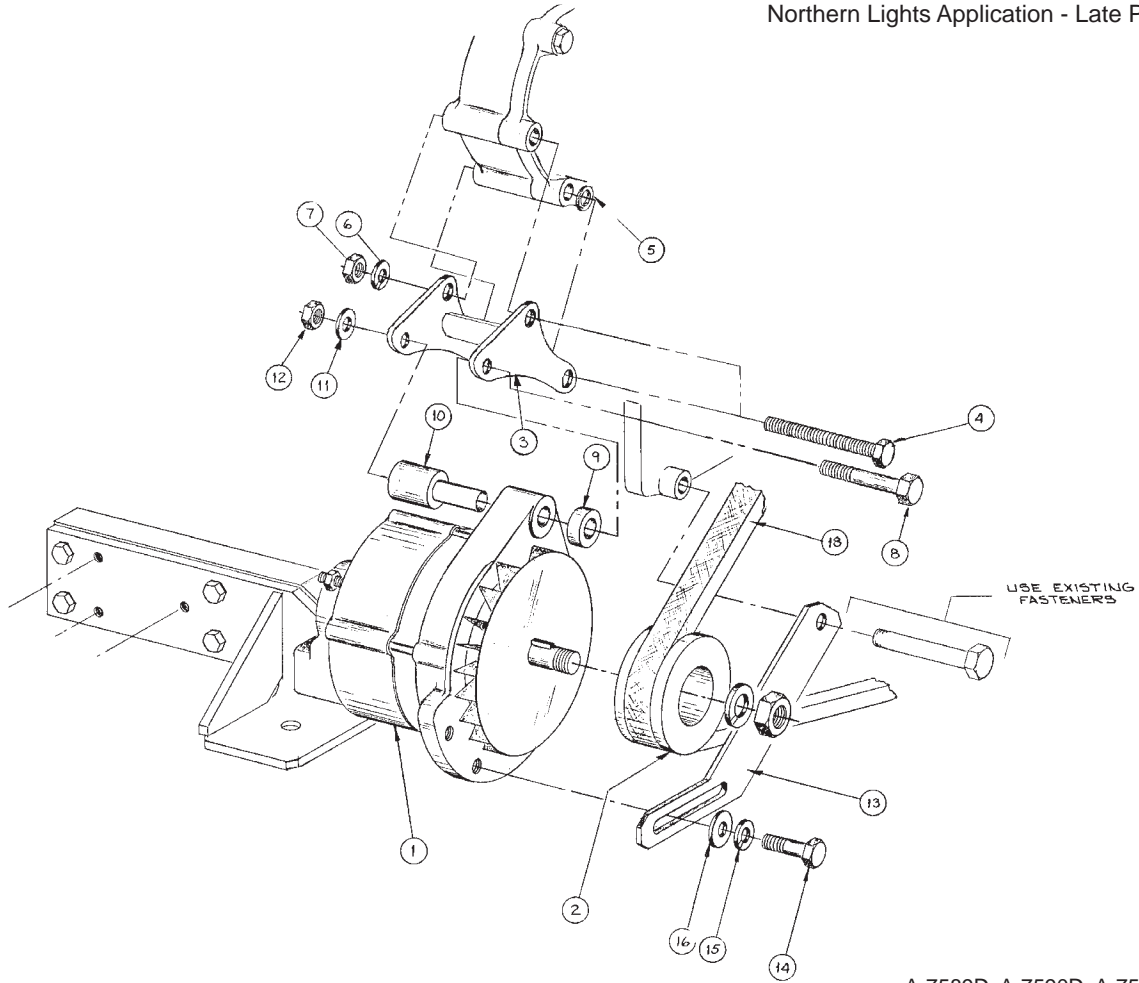

A-7589D, A-7590D, A-7591D/ C-4879

KEY	PART NUMBER	QTY	DESCRIPTION	SERIAL NUMBER
1	22-40332	1	Alternator 12 Volt / 90 Amp	-
	22-40278	1	Alternator 24 Volt / 40 Amp	-
	22-71052	1	Alternator 24 Volt / 35 Amp	-
2	34-42001	1	Pulley 1-A/B x 1-1/2" x 5/8" ID	-
3	23-45418	1	Bracket, Alternator Mounting	-
4	12-50051	2	Capscrew, Hex Head M10 x 1.25 x 90 mm, All Thread	-
5	15-00805	1	Flat Washer M10	-
6	15-00804	2	Wave Washer M10	-
7	14-00814	2	Hex Nut M10 x 1.25	-
8	12-00354	1	Capscrew, Hex Head 3/8-16 x 3-3/4"	-
9	21-45410	1	Spacer	-
10	31-45401	1	Adapter	-
11	15-00321	1	Flat Washer 3/8 SAE	-
12	14-00302	1	Lock Nut, Flanged 3/8-16	-
13	23-42006	1	Tensioning Arm	-
14	12-00213	1	Capscrew, Hex Head 5/16-18 x 1-1/4"	-
15	15-00202	1	Lock Washer 5/16	-
16	15-00201	1	Stud Washer 5/16	-
18	40-05403	1	Drive Belt (without PTO)	-
	40-05405	1	Drive Belt (with PTO)	-
19	22-70048	**	Diode Harness (not shown)	-

**As required

Starter - 12 Volt

Standard Ground

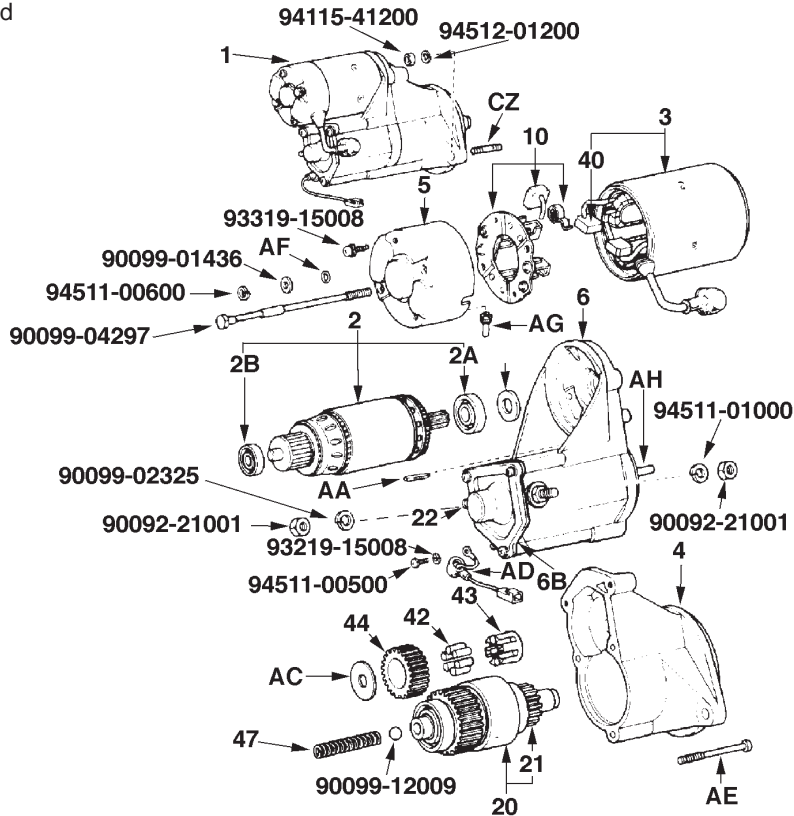

P984 05-13: 1904

KEY	PART NUMBER	QTY	DESCRIPTION	SERIAL NUMBER
01	28100-78502-71	1	Starter Assembly	-
02	28160-47040	1	Starter Armature Assembly	-
02A	90099-10119	1	Armature Bearing #1	-
02B	90099-10107	1	Armature Bearing #2	-
03	28120-47040	1	Starter Yoke Assembly	-
04	28320-96500	1	Starter Drive Housing Assembly	-
05	28340-96500	1	Commutator End Frame Assembly	-
06	28150-96501	1	Magnet Switch Assembly	-
06B	28151-22060-71	1	Rubber Packing (for Starter Yoke)	-
10	28140-77090	1	Starter Brush Holder Assembly	-
20	28011-54010	1	Starter Clutch Sub-Assembly	-
21	28101-22060-71	1	Starter Pinion Sub-Assembly	-
22	28105-22060-71	1	Contact Chip Sub-Assembly	-
40	28141-22060-71	2	Starter Brush	-
41	90099-02205	1	Felt Starter Washer	-
42	28228-56080	5	Starter Idle Gear Clutch Roller	-
43	28229-56080	1	Starter Idle Gear Retainer	-
44	28254-77090	1	Starter Idle Gear	-
47	28165-77090	1	Starter Magnet Switch Return Spring	-
AA	28118-77090	1	Plate	-
AC	28222-77090	1	Idle Gear Clutch Washer	-
AD	28139-77110	1	Lead Wire	-
AE	90099-96500	1	Bolt	-
AF	28317-22060-71	1	O-Ring	-
AG	28199-77090	1	End Frame Cover	-
AH	28106-22060-71	1	Contactor Plunger Sub-Assembly	-
CZ	90116-12011	1	Stud Bolt	-

Main Instrument Panel “Vanguard”

12 Volt Luger Applications

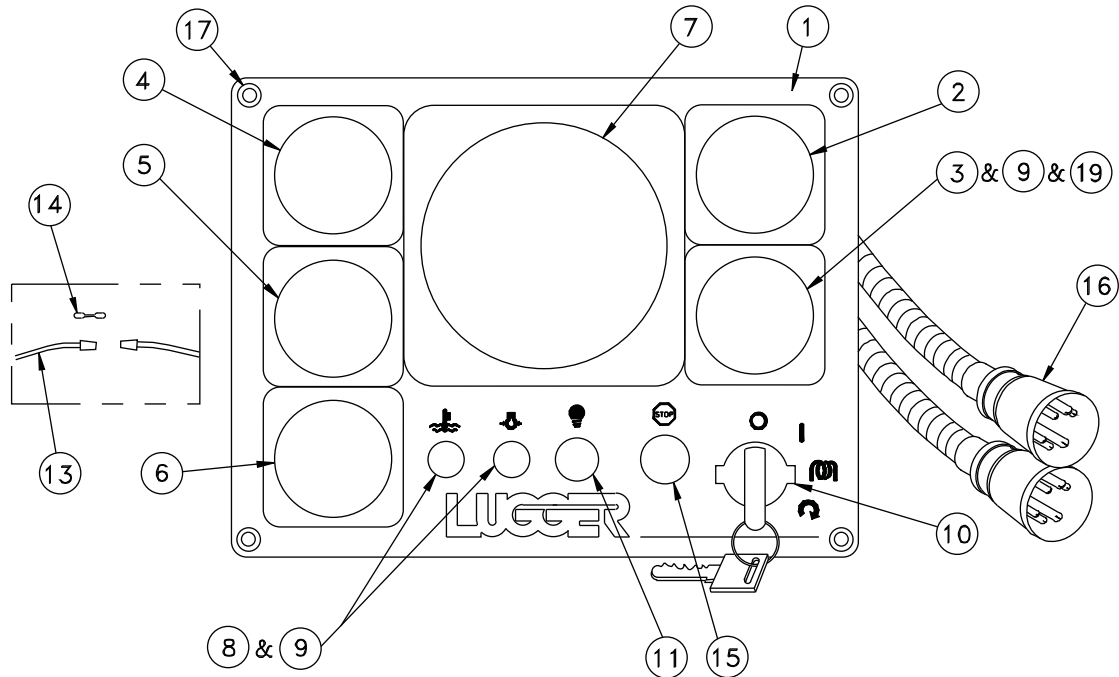

A-7687/ B-4734-2

KEY	PART NUMBER	QTY	DESCRIPTION	SERIAL NUMBER
••	22-95455	1	12 Volt Main Instrument Panel (includes all keys)*	-
1	28-96801	1	Panel Plate	-
2	37-90022	1	Voltmeter, 12 Volt	-
3	37-90024	1	Hourmeter	-
4	37-90025	1	Temperature Gauge, 12 Volt	-
5	37-90033	**	Oil Pressure Gauge 0-80 PSI, 12 Volt	-
	37-90027	1	Oil Pressure Gauge 0-150 PSI, 12 Volt	-
6	22-40263	1	Alarm Horn 12/24 Volt (replaces former #22-44854 & #22-44855)	-
7	37-95403	1	Tachometer 0-3000 RPM, 12 Volt	-
8	22-44851	2	Fault Lamp Holder, Amber	-
9	22-44852	**	Bulb, Clear 12 Volt	-
10	37-94803	1	Key Switch	-
11	22-40247	1	Toggle Switch (for panel lights)	-
12	22-41060	2	Diode (not shown)	-
13	22-00044	1	Fuse Holder	-
14	22-41008	1	Fuse, 7-1/2 Amp	-
15	37-91007	1	Push Button	-
16	22-44859	1	Wire Harness	-
17	22-44861	1	Red Diffuser (for hourmeter)	-
19	12-90002	4	Screw, Self Tapping #8	-
20	37-94814	**	Key, Single Sided	-
	37-96805	**	Key, Double Sided	-
			**As required	
			*Note: 150 PSI Gauge now standard. Order Oil Pressure Sender as required.	

Main Instrument Panel “Vanguard”

24 Volt Luger Applications

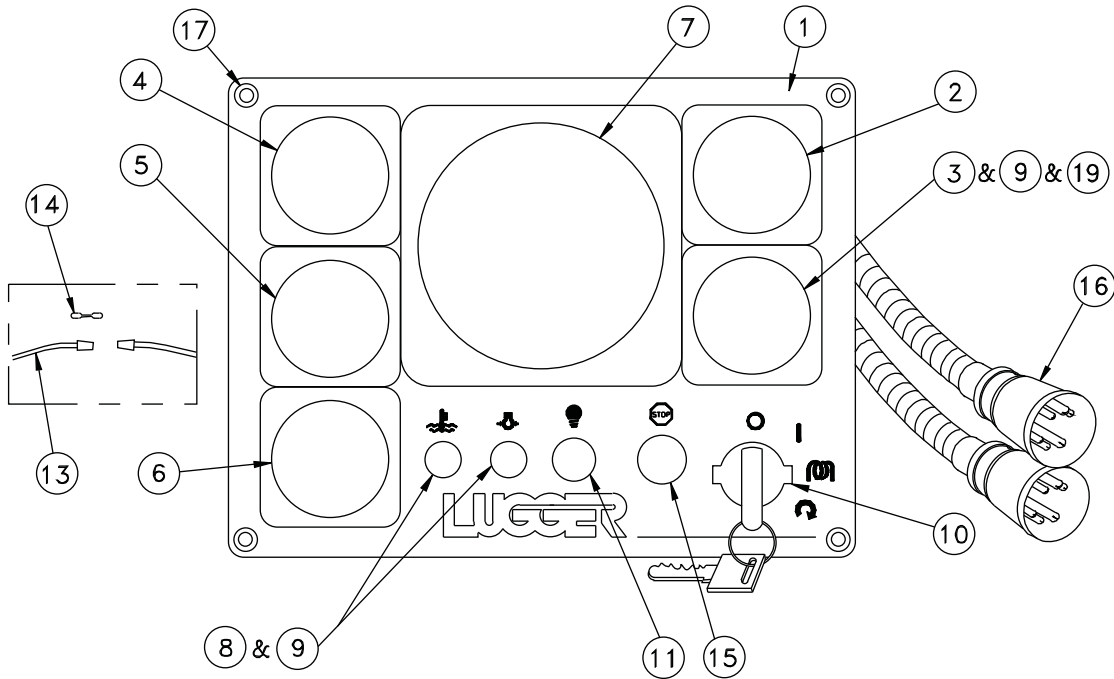

A-7687/ B-4734-2

KEY	PART NUMBER	QTY	DESCRIPTION	SERIAL NUMBER
••	22-95465	1	24 Volt Main Instrument Panel (includes all keys)*	-
1	28-96801	1	Panel Plate	-
2	37-90073	1	Voltmeter, 18 - 32 VCD, Square Bezel	-
3	37-90074	1	Hourmeter, 12/24 Volt, Square Bezel	-
4	37-90026	1	Temperature Gauge, 250°F 24 Volt	-
5	37-90080	**	Oil Pressure Gauge 0-150 PSI, 24 Volt Square Bezel	-
6	22-40263	1	Alarm Horn 12/24 Volt	-
7	37-95404	1	Tachometer 0-3000 RPM, 24 Volt	-
8	22-44851	2	Fault Lamp Holder, Amber	-
9	22-44853	**	Bulb, Clear 24 Volt	-
10	37-94803	1	Key Switch	-
11	22-40247	1	Toggle Switch (for panel lights)	-
12	22-41060	2	Diode (not shown)	-
13	22-00044	1	Fuse Holder	-
14	22-41008	1	Fuse, 7-1/2 Amp	-
15	00-40008	1	Plug 5/8" O.D. Black Nylon	-
16	22-44859	1	Wire Harness	-
17	12-90002	4	Screw, Self Tapping #8	-
18	00-90043	1	Label, Panel Electrical Load Warning (not shown)	-
19	22-44861	1	Bulb Diffuser, Red	-
			**As required	
			*Note: 150 PSI Gauge now standard. Order Oil Pressure Sender as required.	

Flybridge Panel

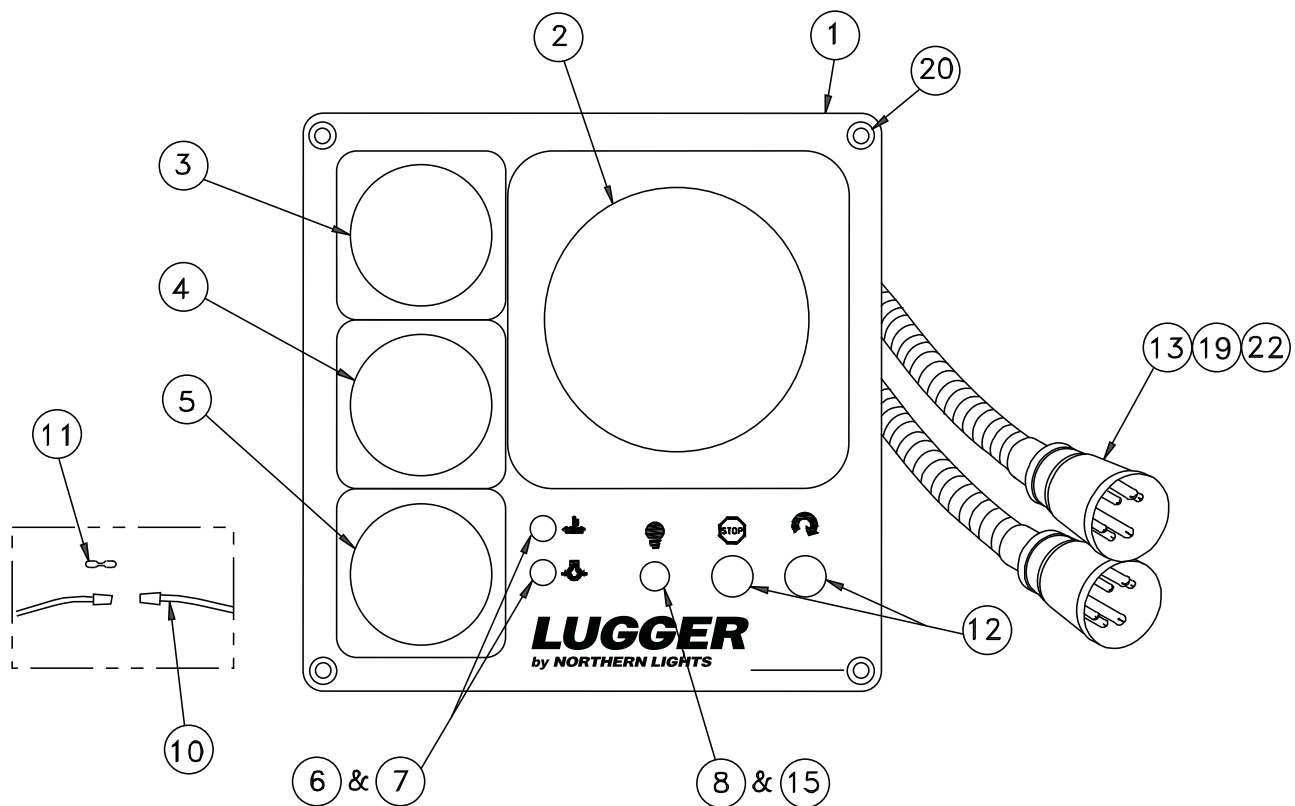

A-9863/ B-4734-3a

KEY	PART NUMBER	QTY	DESCRIPTION	SERIAL NUMBER
••	22-95495	1	Flybridge Panel Kit 12 Volt (includes all keys)	-
•	22-95494	1	Flybridge Panel 12 Volt (includes keys 1-16)	-
1	28-96802	1	Plate, Flybridge Panel	-
2	37-95403	1	Tachometer, 0-3000 RPM 12 Volt Vanguard	-
3	37-90027	1	Pressure Gauge, 0-150 PSI 12 Volt Vanguard	-
4	37-90025	1	Temperature Gauge, 250°F 12 Volt Vanguard	-
5	22-40263	1	Alarm Horn, 12/24 Volt Blue Line & Vanguard	-
6	22-44851	2	Lamp Holder, Amber Lens	-
7	22-44852	2	Bulb, Clear 12 volt	-
8	22-40247	1	Toggle Switch, SPST Maintained Black HDWE	-
9	22-41060	2	Diode, 6 Amp 100 Volt (not shown)	-
10	22-00044	1	Fuse Holder, In-line 15 Amp 32 Volt	-
11	22-41008	1	Fuse, 7-1/2 Amp 250 VAC/DC	-
12	37-91007	1	Switch, Push Button	-
13	22-90003	1	Wire Harness, Dual Station	-
14	00-90043	1	Label, Panel Electrical Load Warning (not shown)	-
15	22-40361	1	Boot, Toggle Switch	-
16	00-40008	1	Plug, 5/8" OD Black Nylon (not shown)	-
17	22-44872	1	Sender, Pressure 1-150 PSI Std. Ground Dual Station (not shown)	-
18	22-40352	1	Sender, Temperature 250°F Std. Ground Dual Station (not shown)	-
19	22-71009	1	Y-Harness Double Plug	-
20	12-90002	4	Self-tapping Screw	-
21	21-00530	1	Plug, Hex Head Brass 1/2 NPT (not shown)	-
22	22-41001	1	10' Wire Harness Extension, Double Plug	-

Series 1 Control Panel - 12 & 24 Volt

Marine Generator Application

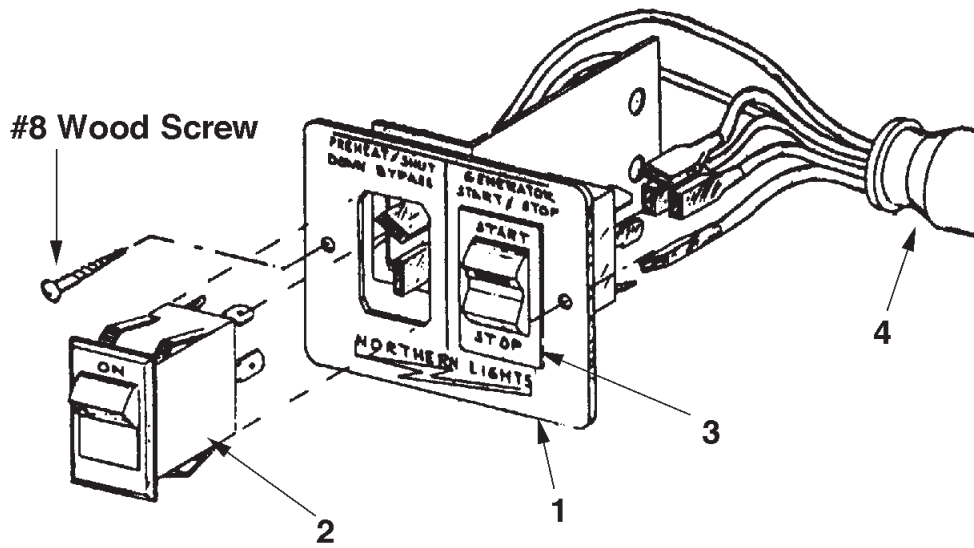

A-2863 + A-4793 / B-2873

KEY	PART NUMBER	QTY	DESCRIPTION	SERIAL NUMBER
••		1	Series 1 Control Panel - 12 Volt (includes all keys) *	-
••		1	Series 1 Control Panel - 24 Volt (includes all keys) *	-
1	00-40013	1	Plate	-
2		1	Preheat/Shutdown-Bypass Switch **	-
3		1	Engine Control Switch **	-
4	22-90009	1	Wire Harness	-
5	22-40012	1	Resistor, 200 Ohm 2 Watt - 24 Volt Only (not shown)	-
			* Replaced by 22-90610 (12 Volt) or 22-90615 (24 Volt) as required.	
			** Replaced by switch retrofit kit 22-90195.	

S-1 Control Panel 12 & 24 Volt

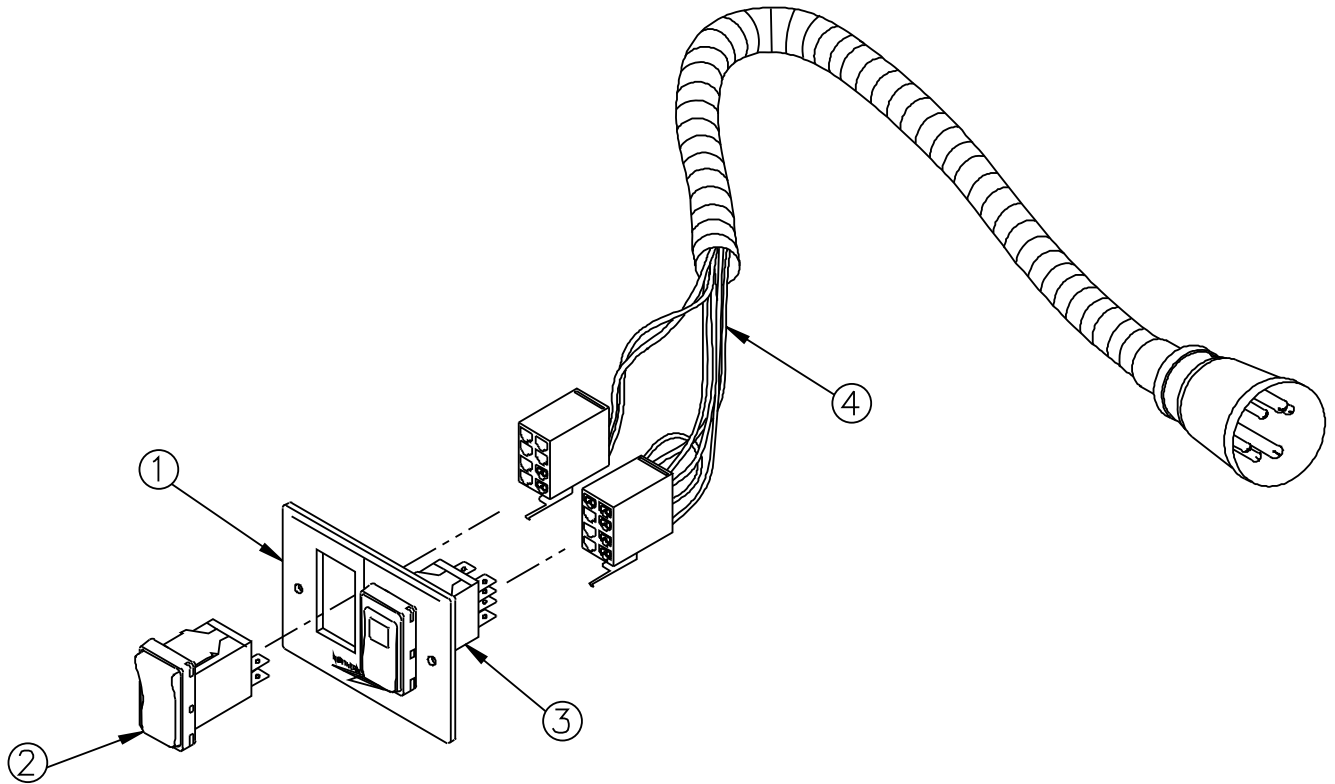

A-8551, A-8552/ B-5970

KEY	PART NUMBER	QTY	DESCRIPTION	SERIAL NUMBER
••	22-92110	1	S-1 Start/Stop Control Panel, 12 Volt (includes all keys)	-
••	22-92115	1	S-1 Start/Stop Control Panel, 24 Volt (includes all keys)	-
1	00-40013	1	Plate, S-1 Control Panel	-
2	22-90167	1	Rocker Switch	-
3	22-90168	1	Rocker Switch	-
4	22-42066	1	Wire Harness, 12 Volt	-
	22-42067	1	Wire Harness, 24 Volt	-
5	00-00013	1	Label "12 Volt" *	-
	00-00014	1	Label "24 Volt" *	-
6	22-40012	1	Resistor, 24 Volt 200 Ohm, 3 Watt *	-
			*Not shown	

Series 1-B Control Panel - 12 & 24 Volt

Marine Generator Application

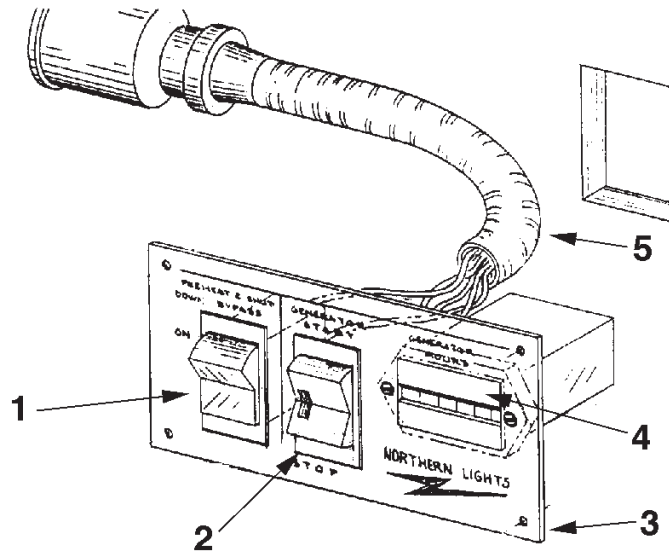

A-4791 + A-3171 / C-1911

KEY	PART NUMBER	QTY	DESCRIPTION	SERIAL NUMBER
••		1	Series 1-B Control Panel - 12 Volt (includes all keys) *	-
••		1	Series 1-B Control Panel - 24 Volt (includes all keys) *	-
1		1	Preheat/Shutdown-Bypass Switch **	-
2		1	Engine Control Switch **	-
3	28-90003	1	Plate	-
4	22-90009	1	Hour Meter	-
5	22-40019	1	Wire Harness	-
6	22-40012	1	Resistor, 200 Ohm 2 Watt - 24 Volt Only (not shown)	-
			* Replaced by 22-92120 (12 Volt) or 22-92125 (24 Volt)	
			** Replaced by switch retrofit kit 22-90195	

S-1B Control Panel 12 & 24 Volt

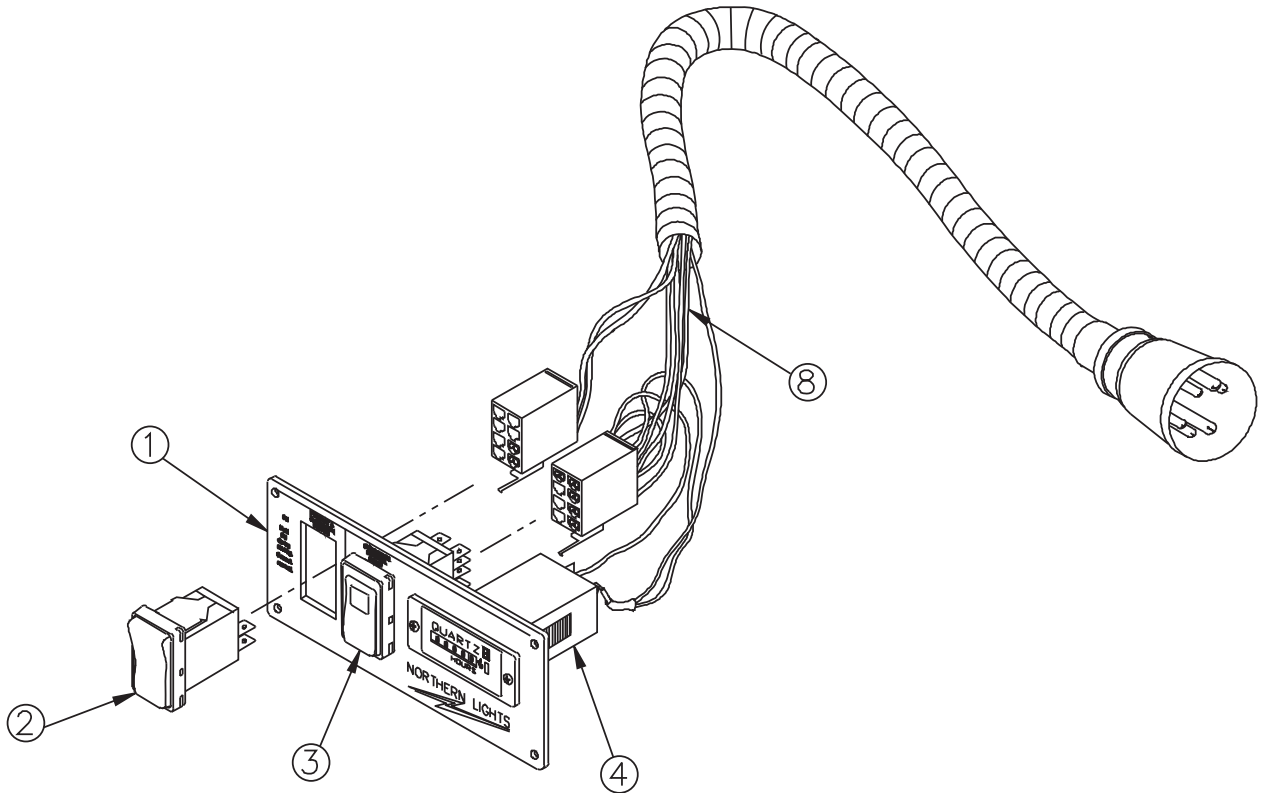

A-8553-4 / B-5971

KEY	PART NUMBER	QTY	DESCRIPTION	SERIAL NUMBER
••	22-92120	1	S-1B Control Panel Assembly, 12 Volt (includes all keys)	-
••	22-92125	1	S-1B Control Panel Assembly, 24 Volt (includes all keys)	-
1	28-90003	1	Plate, S-1B Control Panel	-
2	22-90167	1	Rocker Switch	-
3	22-90168	1	Rocker Switch	-
4	22-90009	1	Hourmeter	-
5	12-00093	2	Machine Screw, Round Head #6-32 x 1/2" S/S *	-
6	15-00030	2	Star Washer *	-
7	14-00015	2	Hex Nut *	-
8	22-42063	1	Wire Harness without Resistor 12V	-
	22-42064	1	Wire Harness with Resistor 24V	-
9	00-00013	1	Label "12 Volt" *	-
	00-00014	1	Label "24 Volt" *	-
10	22-40012	1	Resistor, 200 OHM **	-
			*Not shown	
			**Note: Shown for spare parts reference, included in Harness Assembly.	

Flush Mount S-3C Control Panel 12 & 24 Volt

Generator Set Applications

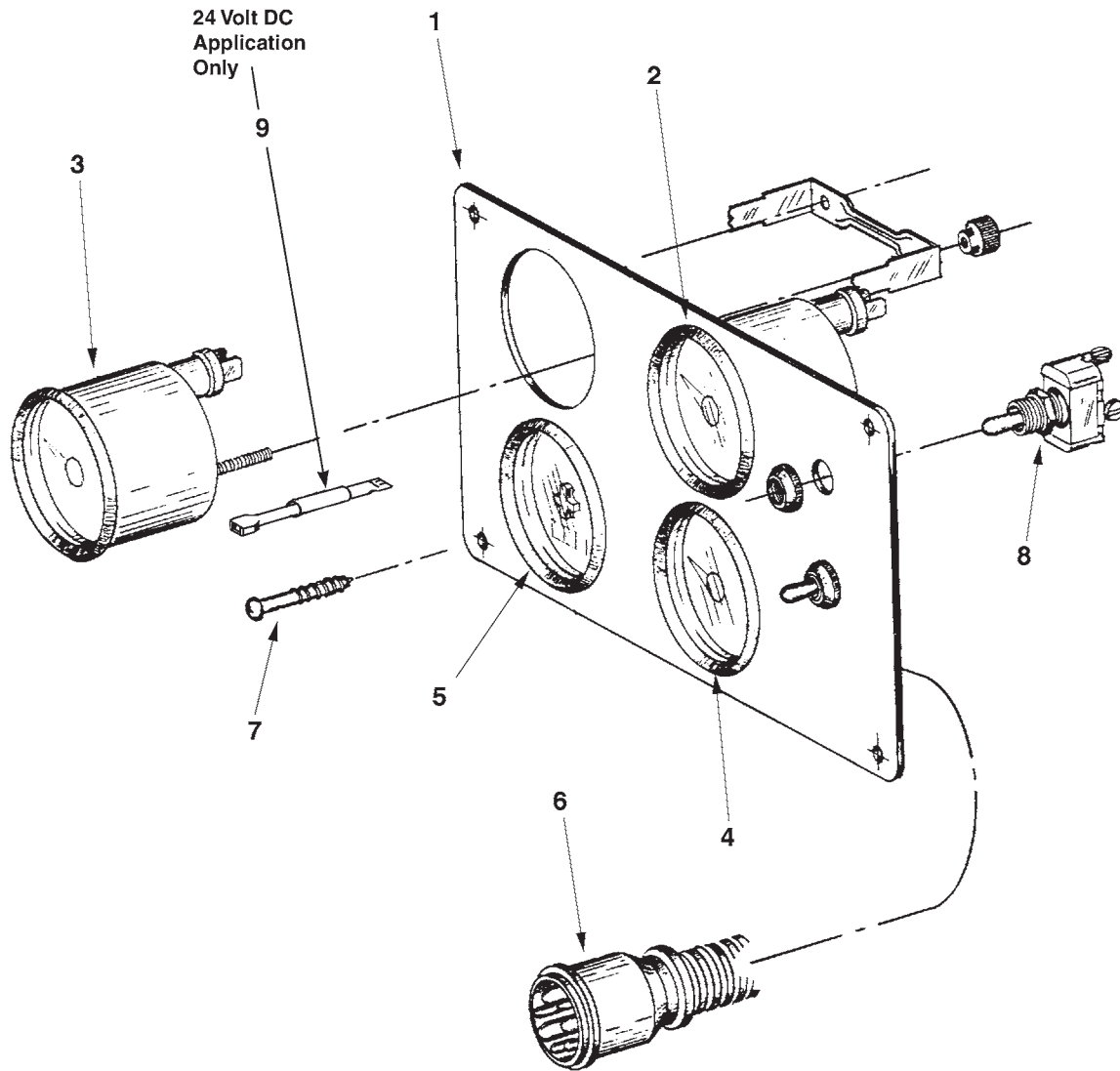

A-4597, A-4597 / C-2441

KEY	PART NUMBER	QTY	DESCRIPTION	SERIAL NUMBER
••	22-92015	1	S-3C Control Panel 12 Volt (includes all keys)	-
••	22-92014	1	S-3C Control Panel 24 Volt (includes all keys)	-
1	28-90010	1	Panel Plate	-
2	37-40010	1	Oil Pressure Gauge, 0-80 PSI	-
3	37-40011	1	Engine Temperature Gauge, 0-250°F	-
4	37-40012	1	DC Voltmeter, 12 Volt	-
	37-40014	1	DC Voltmeter, 24 Volt	-
5	27-40013	1	Hourmeter	-
6	22-42024	1	Panel Wire Harness (not shown)	-
7	12-90007	**	Self Tapping Screw, Oval Head Phillips #6 x 3/4"	-
8	22-41051	2	Toggle Switch	-
9	22-40004	2	Resistor Kit (24 Volt panel only)	-
10	22-44852	**	12 Volt Bulb (not shown)	-
	22-44853	**	24 Volt Bulb (not shown)	-
			**As required	

Flush Mount S-3C Control Panel 12 & 24 Volt

Generator Set Applications

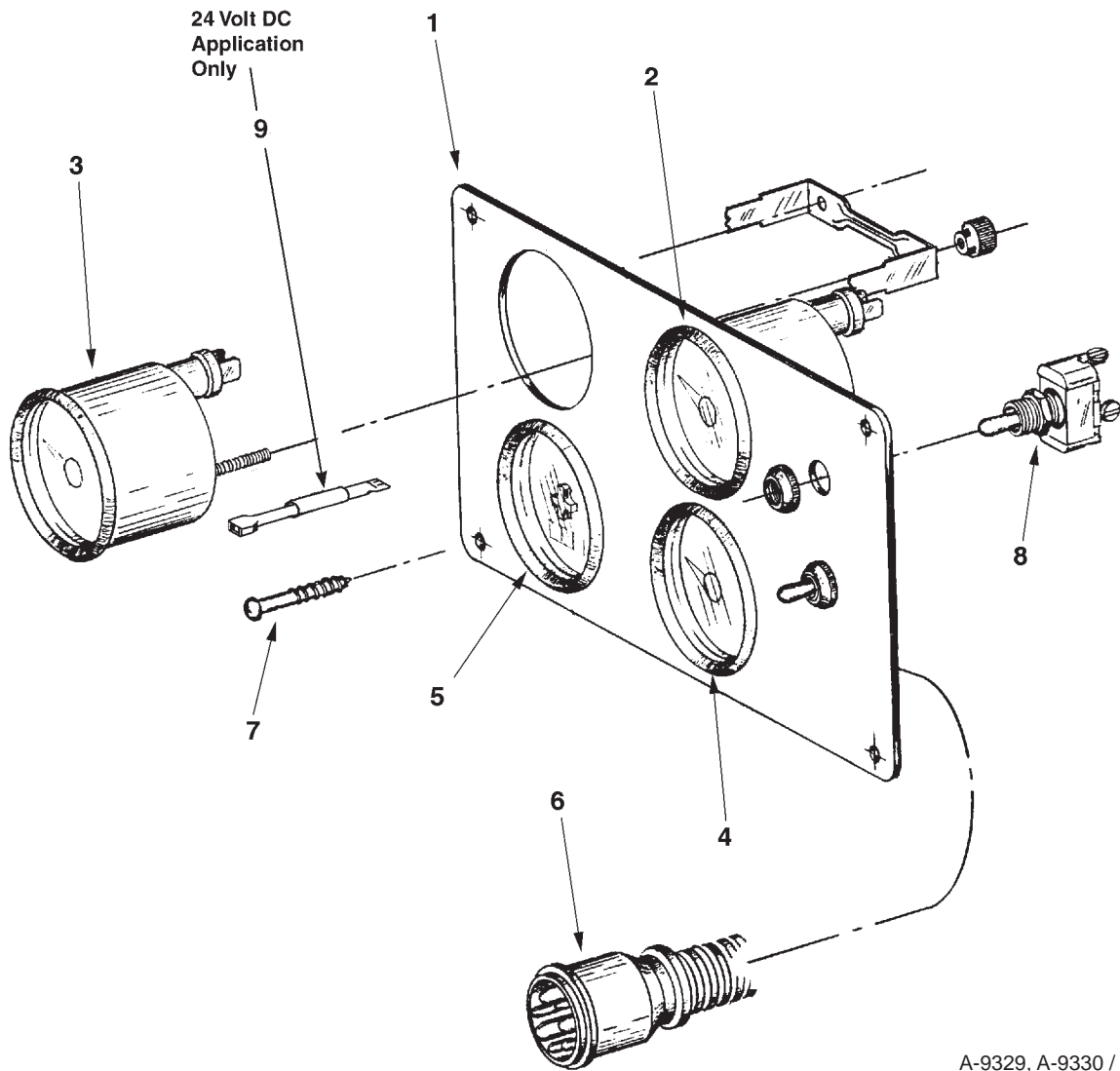

A-9329, A-9330 / C-2441

KEY	PART NUMBER	QTY	DESCRIPTION	SERIAL NUMBER
••	22-95440	1	S-3C Control Panel 12 Volt (includes all keys)	-
••	22-95450	1	S-3C Control Panel 24 Volt (includes all keys)	-
1	28-90010	1	Panel Plate	-
2	37-40015	1	Oil Pressure Gauge, 0-150 PSI	-
3	37-40011	1	Engine Temperature Gauge, 0-250°F	-
4	37-40012	1	DC Voltmeter, 12 Volt	-
	37-40014	1	DC Voltmeter, 24 Volt	-
5	27-40013	1	Hourmeter	-
6	22-42024	1	Panel Wire Harness (not shown)	-
7	12-90007	**	Self Tapping Screw, Oval Head Phillips #6 x 3/4"	-
8	22-41051	2	Toggle Switch	-
9	22-40004	2	Resistor Kit (24 volt panel only)	-
10	22-44852	**	12 Volt Bulb (not shown)	-
	22-44853	**	24 Volt Bulb (not shown)	-
			**As required	

S-3B Control Panel 12 Volt & 24 Volt

Generator Set Applications

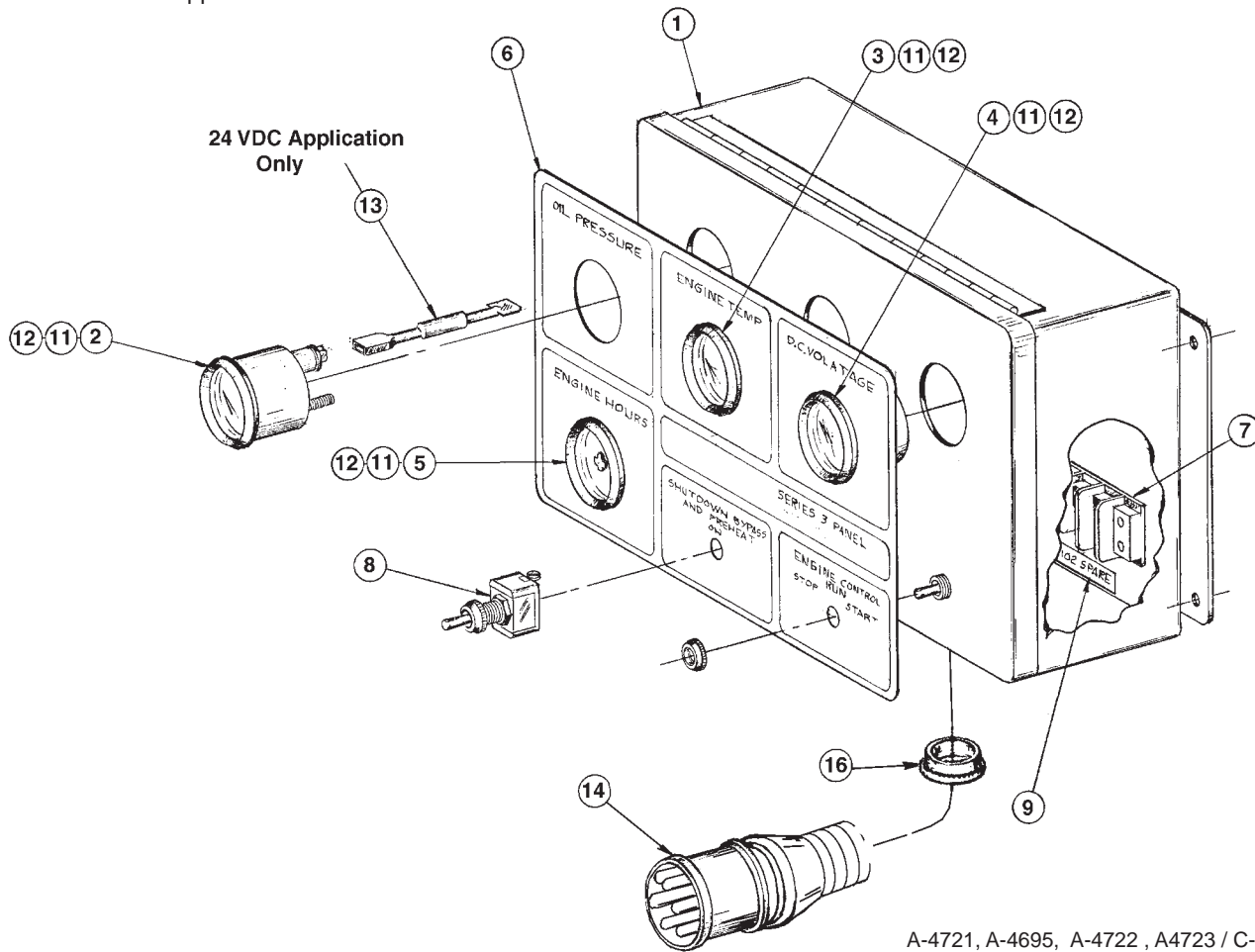

A-4721, A-4695, A-4722, A4723 / C-2470

KEY	PART NUMBER	QTY	DESCRIPTION	SERIAL NUMBER
••	22-92031	1	S-3B Control Panel, 12 Volt	-
••	22-95420	1	S-3B Control Panel, 24 Volt	-
1	39-40008	1	Enclosure	-
2	37-40010	1	Oil Pressure Gauge 0 - 80 PSI	-
3	37-40011	1	Engine Temperature Gauge 0° - 250°F	-
4	37-40012	1	DC Voltmeter, 12 Volt	-
	37-40014	1	DC Voltmeter, 24 Volt	-
5	37-40013	1	Hourmeter, Standard Line	-
6	00-91018	1	Series 3 Control Panel Decal	-
7	22-41077	1	Terminal Board	-
8	22-41051	2	Switch	-
9	22-00052	1	Number Strip	-
10	22-40257	1	Wire Harness (not shown)	-
11	16-01001	4	O-ring	-
12	37-44852	**	12 Volt Bulb	-
	22-44853	**	24 Volt Bulb	-
13	22-40004	1	Resistor Kit (24 Volt only)	-
14	22-40062	1	Connection Harness	-
15	14-00019	2	Hex Nut, XL #6-32 x 1/2"	-
16	00-40028	1	Grommet	-
			**As required	

S-3B Control Panel 12 Volt & 24 Volt

Generator Set Applications

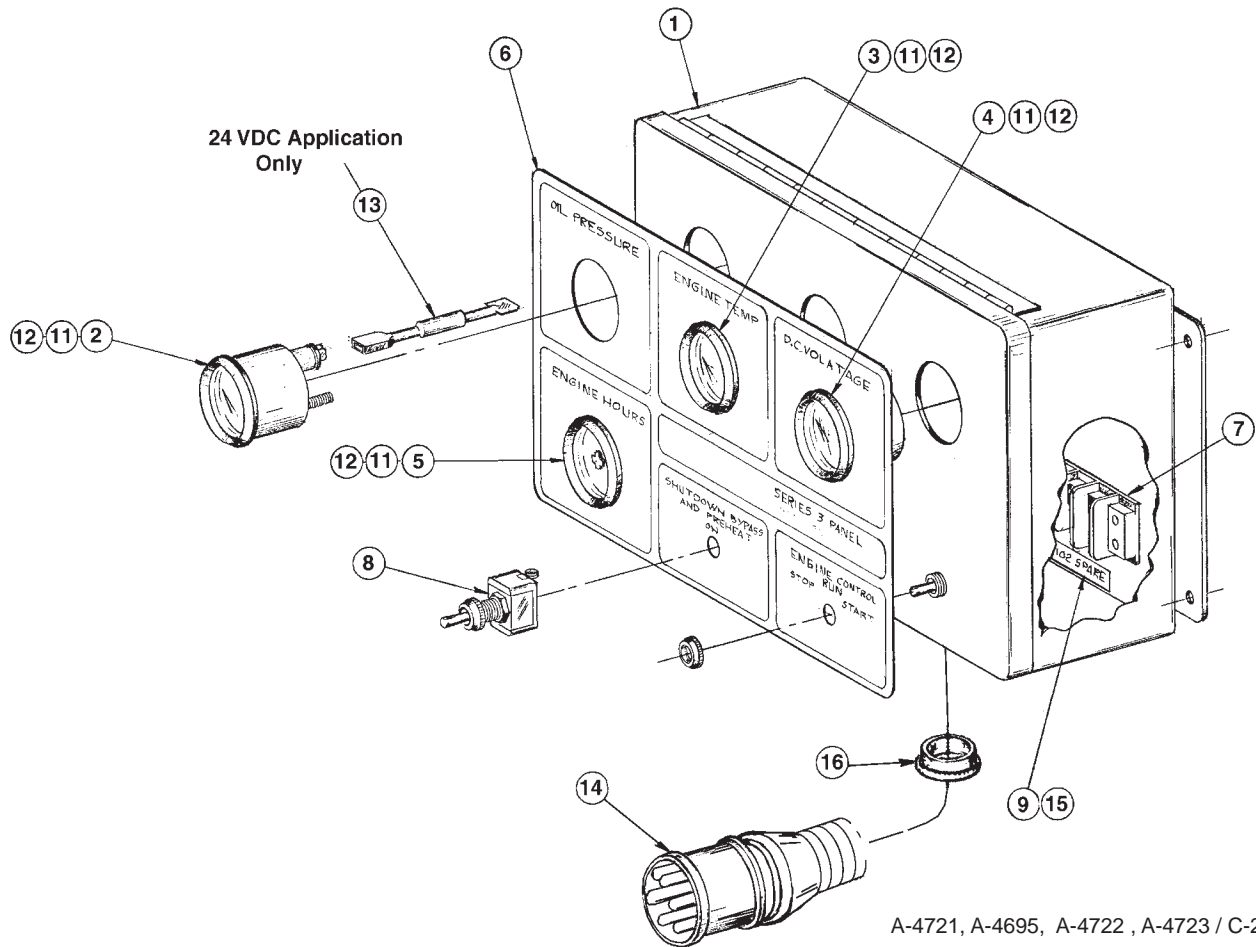

A-4721, A-4695, A-4722, A-4723 / C-2470

KEY	PART NUMBER	QTY	DESCRIPTION	SERIAL NUMBER
••	22-95480	1	S-3B Control Panel, 12 Volt	-
••	22-95485	1	S-3B Control Panel, 24 Volt	-
1	39-40008	1	Enclosure	-
2	37-40015	1	Oil Pressure Gauge 0 - 80 PSI	-
3	37-40011	1	Engine Temperature Gauge 0° - 250°F	-
4	37-40012	1	DC Voltmeter, 12 Volt	-
	37-40014	1	DC Voltmeter, 24 Volt	-
5	37-40013	1	Hourmeter, Standard Line	-
6	00-91018	1	Series 3 Control Panel Decal	-
7	22-41077	1	Terminal Board	-
8	22-41051	2	Switch	-
9	22-00052	1	Number Strip	-
10	22-40257	1	Wire Harness (not shown)	-
11	16-01001	4	O-ring	-
12	37-44852	**	12 Volt Bulb	-
	22-44853	**	24 Volt Bulb	-
13	22-40004	1	Resistor Kit (24 Volt only)	-
14	22-40062	1	Connection Harness	-
15	14-00019	2	Hex Nut, XL #6-32 x 1/2"	-
16	00-40028	1	Grommet	-
			**As required	

Belt Guard & Mounting - Small Frame Alternators

Propulsion Units without PTO

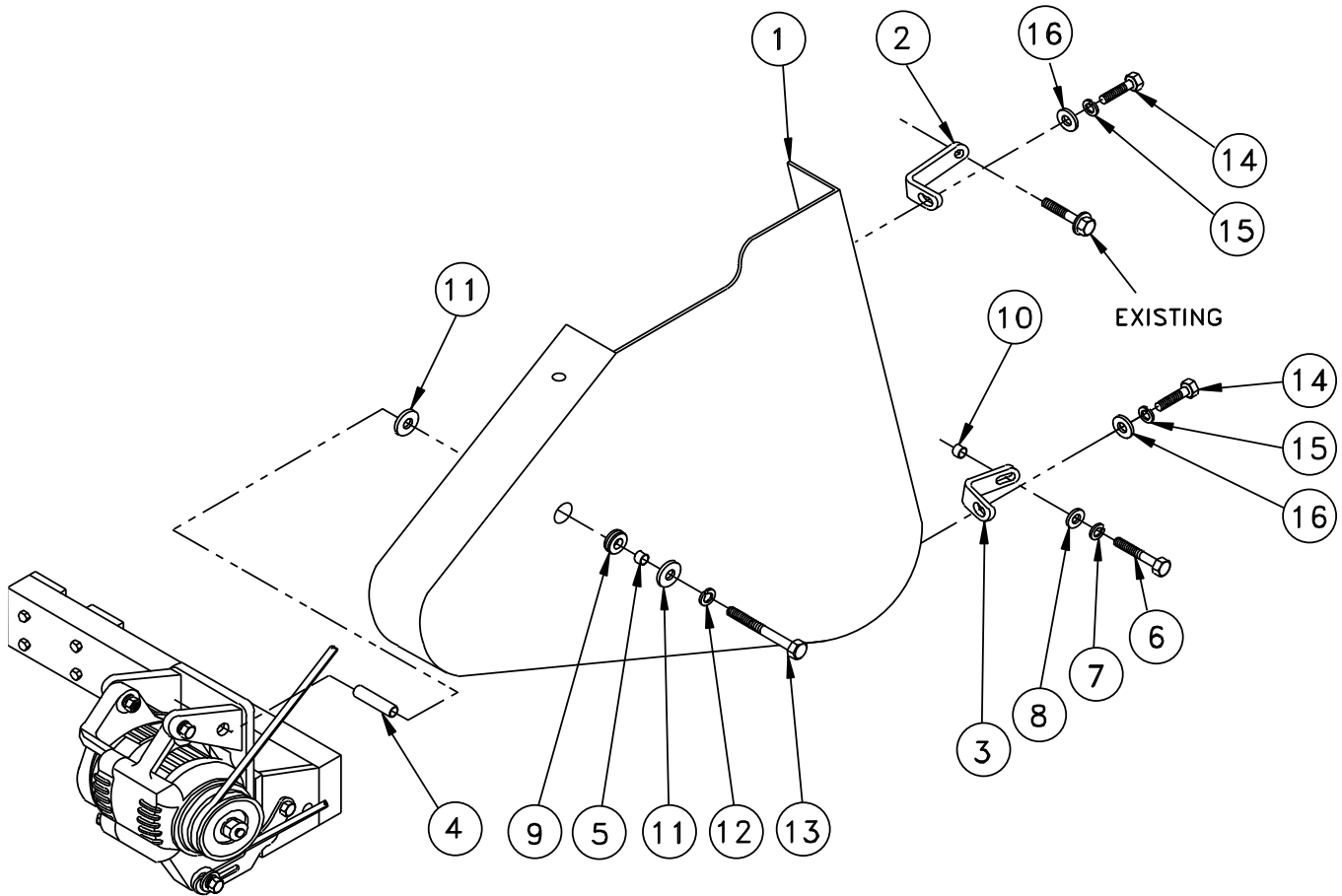

A-7848 / B-6997

KEY	PART NUMBER	QTY	DESCRIPTION	SERIAL NUMBER
1	00-75479	1	Belt Guard for Small Frame Alternators - Heat Exchanged units	-
2	23-05405	1	Bracket	-
3	23-05406	1	Bracket	-
4	21-45403	1	Spacer	-
5	21-75402	1	Spacer	-
6	12-00802	1	Capscrew, Hex Head M10 x 1.25 x 80 mm, Grade 8.8	-
7	15-00802	1	Lock Washer M10	-
8	15-00807	1	Stud Washer M10	-
9	00-00017	1	Grommet	-
10	21-05002	1	Spacer	-
11	15-70004	2	Snubbing Washer S/S	-
12	15-00702	1	Lock Washer M8	-
13	12-00710	1	Capscrew, Hex Head M8 x 1.25 x 90 mm	-
14	12-00776	2	Capscrew, Hex Head M8 x 1.25 x 20 mm S/S	-
15	15-00705	2	Lock Washer M8 S/S	-
16	15-00706	2	Flat Washer M8 S/S	-

Belt Guard & Mounting - Small Frame Alternators

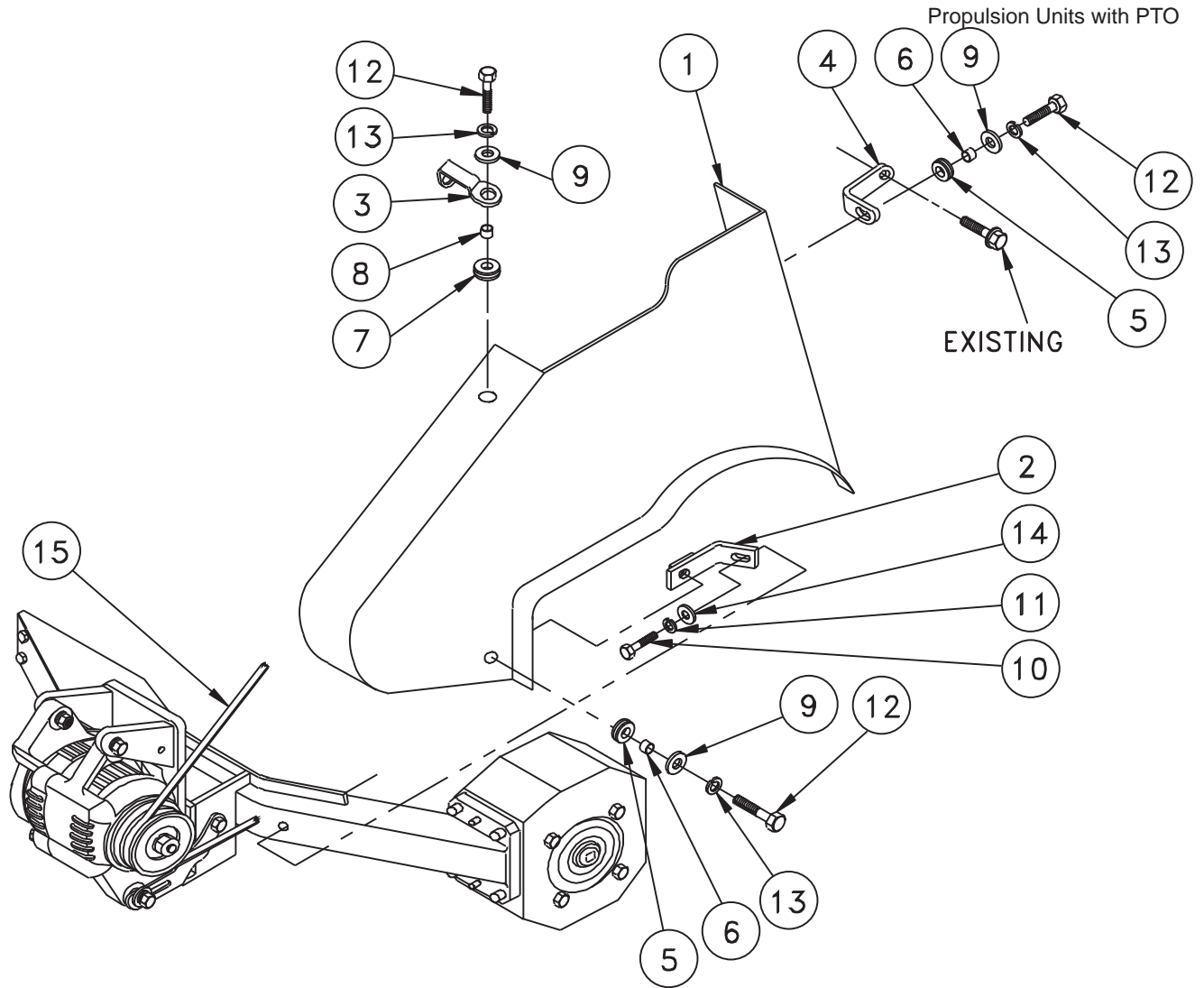

A-8391 / B-6981

KEY	PART NUMBER	QTY	DESCRIPTION	SERIAL NUMBER
1	00-75484	1	Belt Guard for Small Frame Alternators - Heat Exchanged units	-
2	23-05403	1	Bracket	-
3	23-05413	1	Bracket	-
4	23-05405	1	Bracket	-
5	00-00017	2	Grommet	-
6	21-05002	2	Spacer	-
7	00-05409	1	Grommet	-
8	21-05002	1	Spacer	-
9	15-70004	3	Snubbing Washer S/S	-
10	12-00711	1	Capscrew, Hex Head M8 x 1.25 x 20 mm	-
11	15-00702	1	Lock Washer M8	-
12	12-00776	3	Capscrew, Hex Head M8 x 1.25 x 20 mm S/S	-
13	15-00705	3	Lock Washer M8 S/S	-
14	15-00701	1	Flat Washer M8	-
15	40-05407	1	Drive Belt	-

Belt Guard & Mounting - Large Frame Alternators

Propulsion Units without PTO

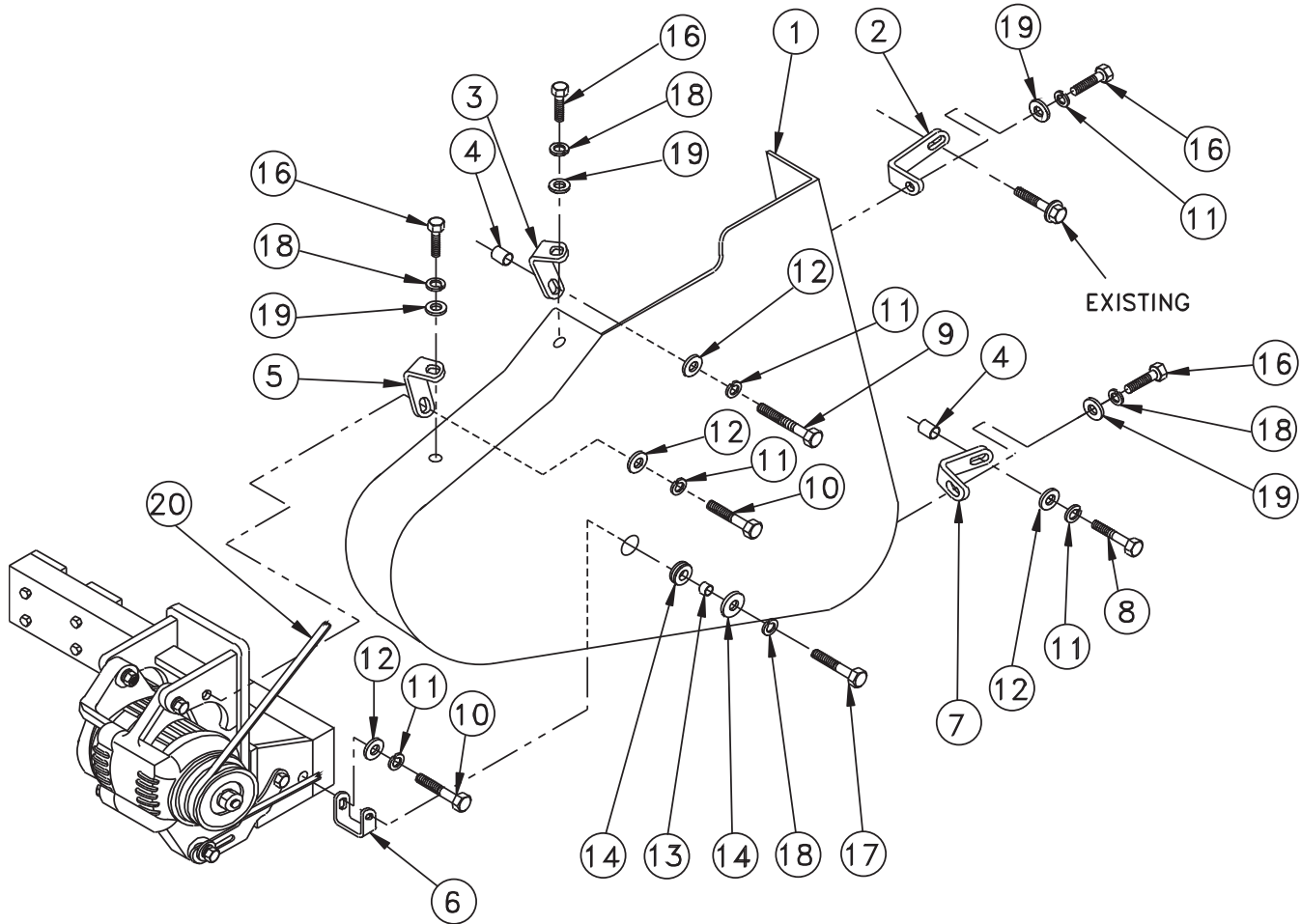

A-7832 / B-7004

KEY	PART NUMBER	QTY	DESCRIPTION	SERIAL NUMBER
1	00-75481	1	Belt Guard for Large Frame Alternators - Heat Exchanged units	-
2	23-05405	1	Bracket	-
3	23-05409	1	Bracket	-
4	21-75402	2	Spacer	-
5	23-05408	1	Bracket	-
6	23-05407	1	Bracket	-
7	23-05406	1	Bracket	-
8	12-00802	1	Capscrew, Hex Head M10 x 1.25 x 80 mm, Grade 8.8	-
9	12-00810	1	Capscrew, Hex Head M10 x 1.25 x 45 mm	-
10	12-00805	2	Capscrew, Hex Head M10 x 1.5 x 20 mm	-
11	15-00802	5	Lock Washer	-
12	15-00805	3	Flat Washer	-
13	21-05002	1	Spacer	-
14	15-70004	1	Snubbing Washer S/S	-
15	00-00017	1	Grommet (not shown)	-
16	12-00776	4	Capscrew, Hex Head M8 x 1.25 x 20 mm S/S	-
17	12-09712	1	Capscrew, Hex Head M8 x 1.25 x 25 mm S/S	-
18	15-00705	4	Lock Washer	-
19	15-00706	4	Flat Washer	-

Belt Guard & Mounting - Small & Medium Frame Alternators

Generator Sets without PTO

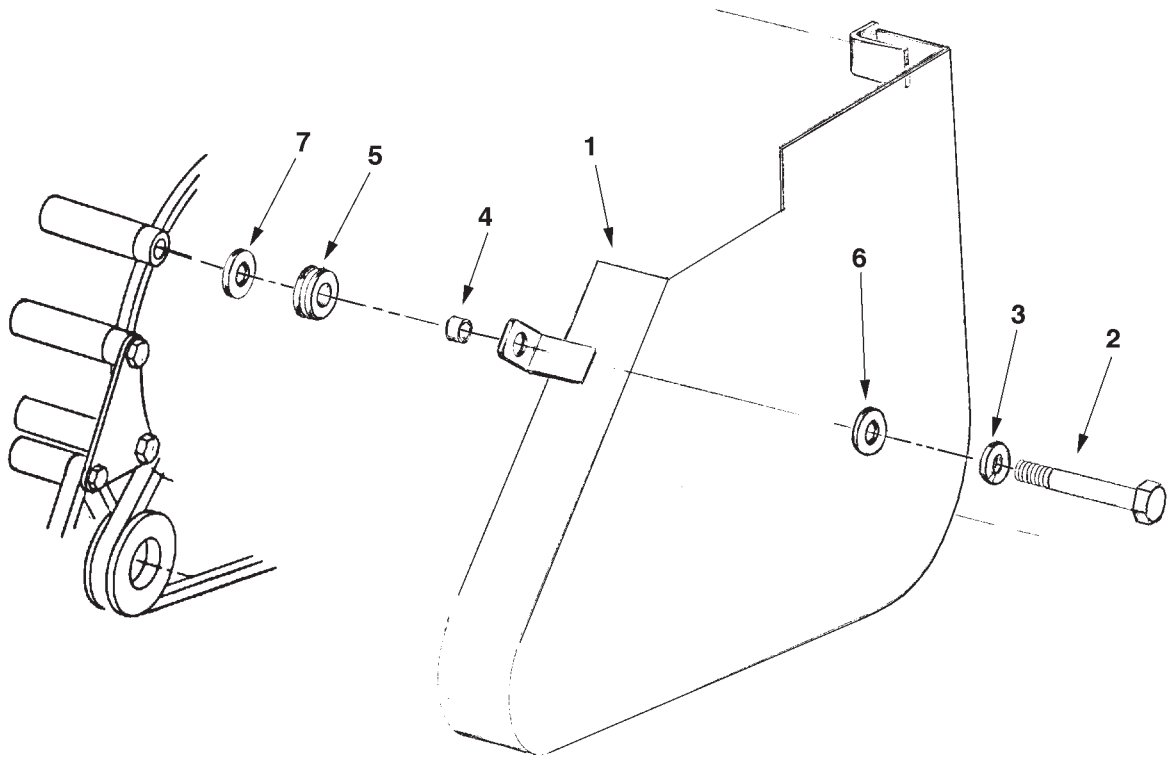

A-4248 / C-2351

KEY	PART NUMBER	QTY	DESCRIPTION	SERIAL NUMBER
1	00-05414	1	Guard for Medium Frame Alternators - Heat Exchanged units	-
	00-75441	1	Guard for Medium Frame Alternators - Heat Exchanged units with belt driven raw water pump	-
	00-75439	1	Guard for 12 Volt 40 Amp Alternator - Heat Exchanged units	-
	00-75443	1	Guard for 12 Volt 40 Amp Alternator - Keel Cooled units	-
2	12-00802	3	Cap screw, Hex Head M10 x 1.25 x 80 mm	-
3	15-00802	3	Lock Washer M10	-
4	21-75407	3	Spacer	-
5	00-75464	3	Grommet	-
6	15-70006	3	Snubbing Washer	-
7	15-00807	3	Stud Washer M10	-

Belt Guard & Mounting - Medium Frame Alternators

Generator Sets with PTO

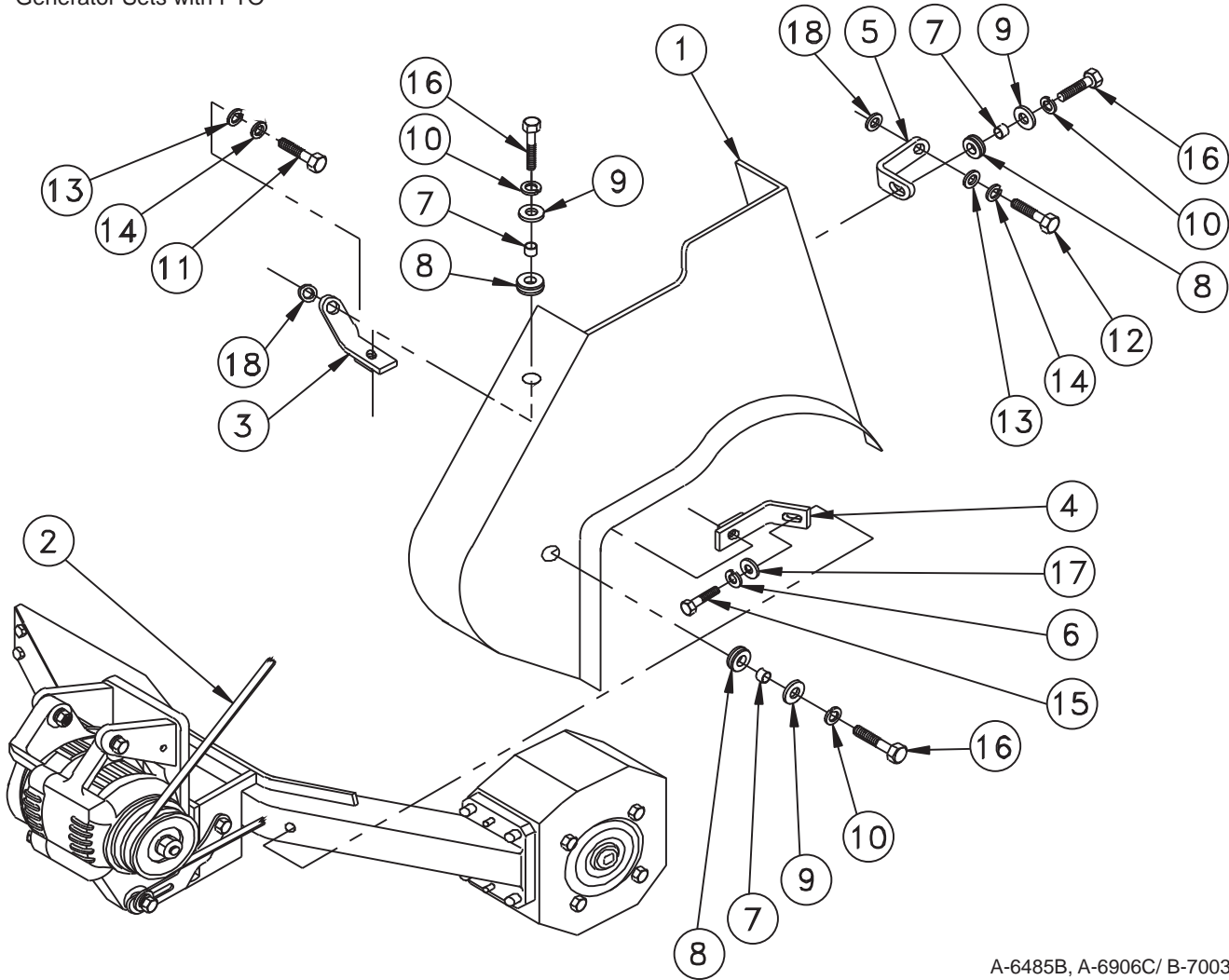

A-6485B, A-6906C/ B-7003

KEY	PART NUMBER	QTY	DESCRIPTION	SERIAL NUMBER
••	23-45409	1	Bracket for Small Frame Alternator	-
1	00-05403	1	Belt Guard for Small & Med. Frame Alternators	-
2	40-05405	2	Drive Belt	-
3	23-05410	1	Bracket	-
4	23-05403	1	Bracket	-
5	23-05411	1	Bracket	-
6	16-00702	1	Lock Washer	-
7	21-05002	3	Spacer	-
8	00-00017	3	Grommet	-
9	15-70004	3	Snubbing Washer, S/S	-
10	15-00705	3	Lock Washer, S/S	-
11	12-00801	1	Capscrew, Hex Head M10 x 1.25 x 70 mm	-
12	12-00802	1	Capscrew, Hex Head M10 x 1.25 x 80 mm	-
13	15-00805	1	Flat Washer	-
14	15-00802	1	Lock Washer	-
15	12-00712	1	Capscrew, Hex Head M8 x 1.25 x 25 mm (Small frame Alternator)	-
	12-00711	1	Capscrew, Hex Head M8 x 1.25 x 20 mm (Med. frame Alternator)	-
16	12-09712	3	Capscrew, Hex Head M8 x 1.25 x 25 mm S/S	-
17	15-00701	1	Flat Washer	-
18	15-00807	2	Stud Washer	-

Overhaul Gasket Set

KEY	PART NUMBER	QTY	DESCRIPTION	SERIAL NUMBER
••	29-05410	1	Overhaul Gasket Set	-
1	04111-20220-71	1	Gasket Kit - Engine Overhaul (components not listed)	-
2	16271-78301-71	1	Coolant Pump	-
3	11-75401	1	PTO Cover	-
4	11-25400	1	Air Intake	-
5	16-25400	4	Air Intake O-Ring	-
6	11-35401	1	Exhaust Elbow	-
7	11-15401	1	Thermostat Housing	-
8	11-10015	1	Thermostat O-Ring	-
9	11-12203	2	Heat Exchanger to Expansion Tank	-
10	20-12012	2	Heat Exchanger End Cover	-
11	16-15401	1	O-Ring, Direct Drive Raw Water Pump	-
12	11176-56020	4	Injector Seat	-
13	90201-08106	8	Return Line Washer	-
14	80430-76075-71	4	Injector Seal (formerly #90430-18014)	-
15	90301-99950-71	1	Injection Pump O-Ring	-
16	94712-77121	8	Fuel Line Washer	-
17	90430-10035	4	Injection Pump Oil Line Washer	-

GROUP 7 – GEAR & ADAPTER SETS

Gear and Adapter Sets

HSW630V1

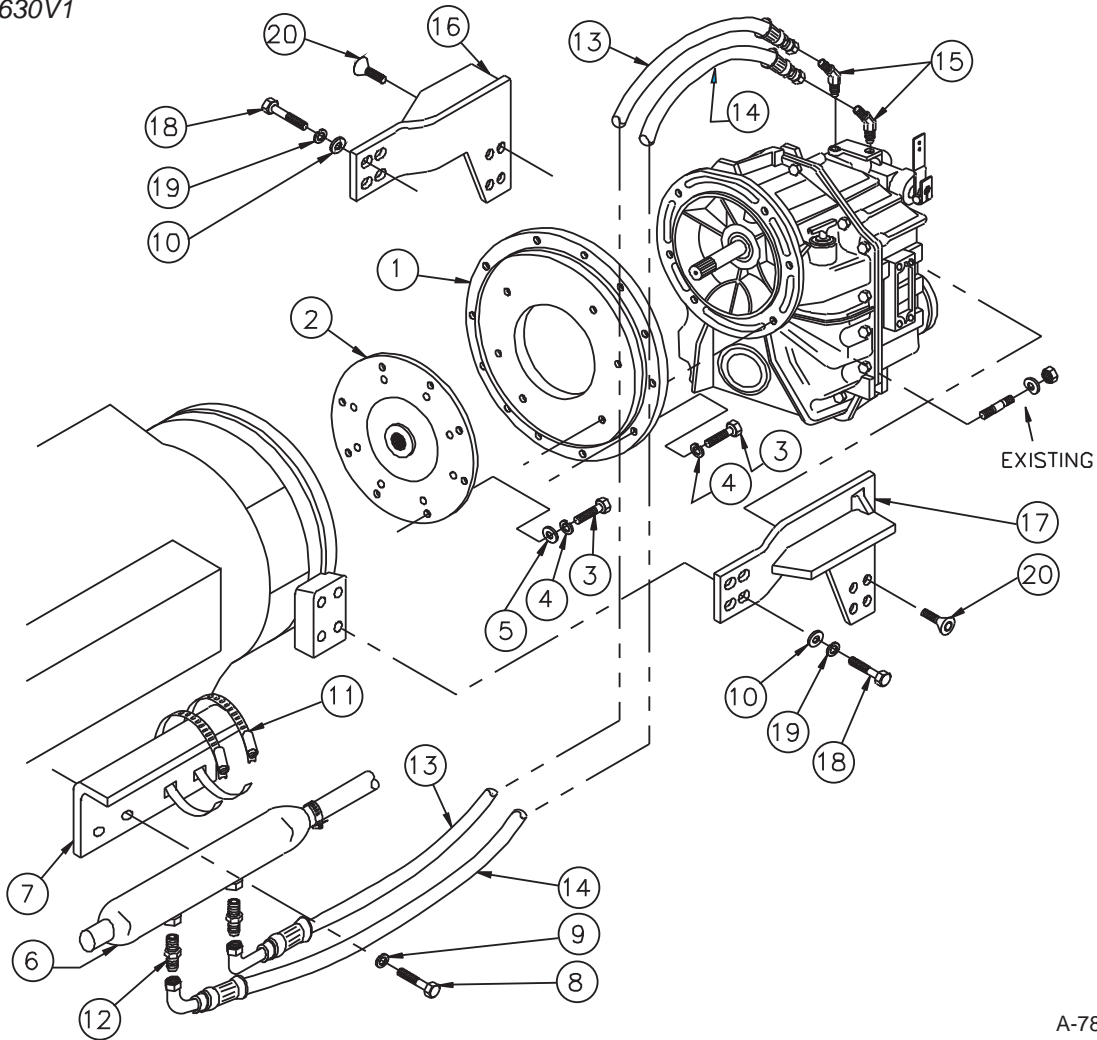

A-7831/ B-7022

KEY	PART NUMBER	QTY	DESCRIPTION	SERIAL NUMBER
1	500-018	1	Adapter SAE #4 x Hurth	-
2	34-61043	1	Drive Damper, Dual Element SAE #10	-
3	12-00312	20	Capscrew, Hex Head 3/8-16 x 1"	-
4	15-00302	12	Lock Washer	-
5	15-00301	8	Flat Washer	-
6	20-65401	1	Gear Oil Cooler	-
7	23-15403	1	Bracket, Gear Oil Cooler Mounting	-
8	12-00808	2	Capscrew, Hex Head M10 x 1.25 x 20 mm	-
9	15-00802	2	Lock Washer	-
10	15-00501	8	Flat Washer 1/2" USS	-
11	19-00020	2	Hose Clamp #20	-
12	12-05405	2	Male Connector, Steel, 1/2 NPT x 1/2-37T	-
13	18-61419	1	Hose Assembly, 1/2" ID x 29"	-
14	18-65703	1	Hose Assembly, 1/2" ID x 33"	-
15	21-71009	2	Male Elbow, 45°, Steel 3/8 NPT x 1/2-37T	-
16	23-65407	1	Bracket, Engine Gear Mounting, Right Hand	-
17	23-65408	1	Bracket, Engine Gear Mounting, Left Hand	-
18	12-00513	8	Capscrew, Hex Head 1/2-13 x 1-1/4"	-
19	15-00502	8	Lock Washer	-
20	12-10914	8	Capscrew, Flat Head Socket, M12 x 1.75 x 35 mm (Grade 10.9)	-

Gear and Adapter Sets

HSW630A & H

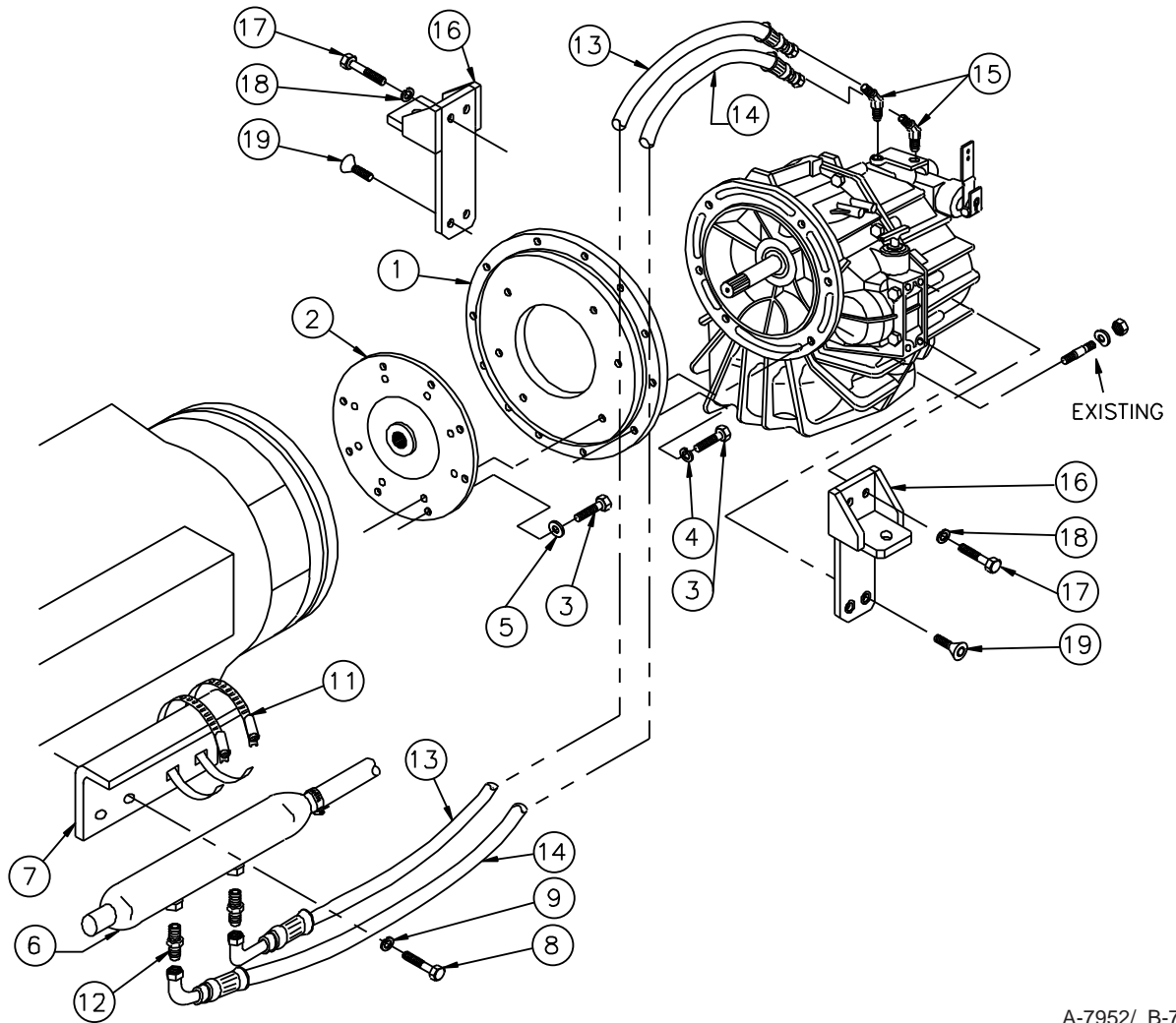

A-7952/ B-7027

KEY	PART NUMBER	QTY	DESCRIPTION	SERIAL NUMBER
1	500-018	1	Adapter SAE #4 x Hurth	-
2	34-61043	1	Drive Damper, Dual Element SAE #10	-
3	12-00312	20	Capscrew, Hex Head 3/8-16 x 1"	-
4	15-00302	12	Lock Washer	-
5	15-00301	8	Flat Washer	-
6	20-65401	1	Gear Oil Cooler	-
7	23-15403	1	Bracket, Gear Oil Cooler Mounting	-
8	12-00808	2	Capscrew, Hex Head M10 x 1.25 x 20 mm	-
9	15-00802	2	Lock Washer	-
11	19-00020	2	Hose Clamp #20	-
12	12-05405	2	Male Connector, Steel, 1/2 NPT x 1/2-37T	-
13	18-61419	1	Hose Assembly, 1/2" ID x 29"	-
14	18-65703	1	Hose Assembly, 1/2" ID x 33"	-
15	21-71009	2	Male Elbow, 45°, Steel 3/8 NPT x 1/2-37T	-
16	23-65411	2	Bracket, Engine Gear Mounting	-
17	12-00954	4	Capscrew, Hex Head M12 x 1.75 x 35 mm	-
18	15-00912	4	Lock Washer	-
19	12-10914	4	Capscrew, Flat Head Socket, M12 x 1.75 x 35 mm (Grade 10.9)	-

Gear and Adapter Sets

HSW450A

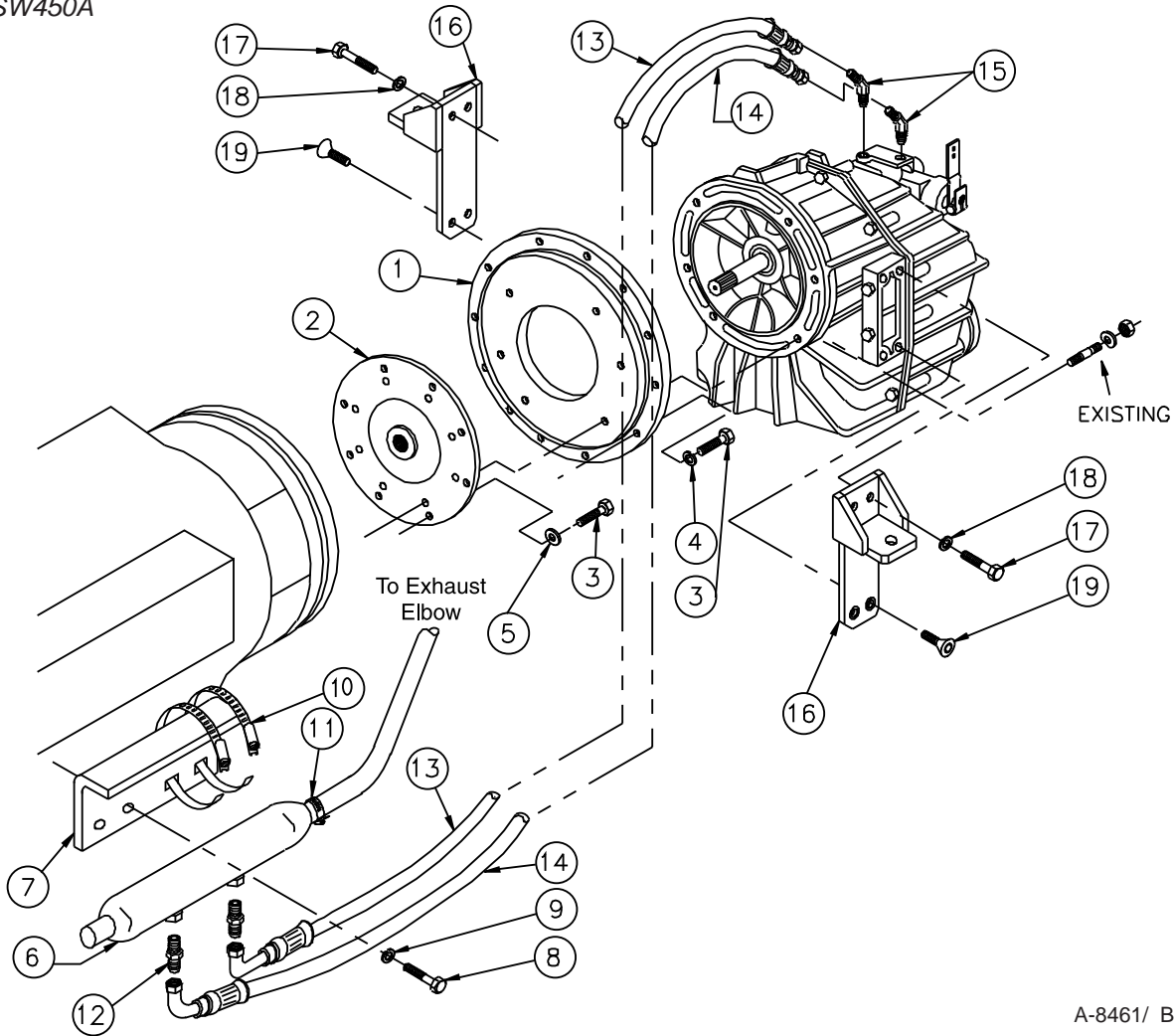

A-8461/ B-7029

KEY	PART NUMBER	QTY	DESCRIPTION	SERIAL NUMBER
1	500-018	1	Adapter SAE #4 x Hurth	-
2	34-61043	1	Drive Damper, Dual Element SAE #10	-
3	12-00312	20	Capscrew, Hex Head 3/8-16 x 1"	-
4	15-00302	12	Lock Washer	-
5	15-00301	8	Flat Washer	-
6	20-65401	1	Gear Oil Cooler	-
7	23-15403	1	Bracket, Gear Oil Cooler Mounting	-
8	12-00808	2	Capscrew, Hex Head M10 x 1.25 x 20 mm	-
9	15-00802	2	Lock Washer	-
10	19-00044	2	Hose Clamp #44	-
11	19-00020	2	Hose Clamp #20	-
12	12-05405	2	Male Connector, Steel, 1/2 NPT x 1/2-37T	-
13	18-65407	1	Hose Assembly, 1/2" ID x 28"	-
14	18-65408	1	Hose Assembly, 1/2" ID x 32"	-
15	21-71009	2	Male Elbow, 45°, Steel 3/8 NPT x 1/2-37T	-
16	23-65405	2	Bracket, Gear Mounting	-
17	12-00954	4	Capscrew, Hex Head M12 x 1.75 x 35 mm	-
18	15-00912	4	Lock Washer	-
19	12-10914	4	Capscrew, Flat Head Socket, M12 x 1.75 x 35 mm (Grade 10.9)	-

Gear and Adapter Sets

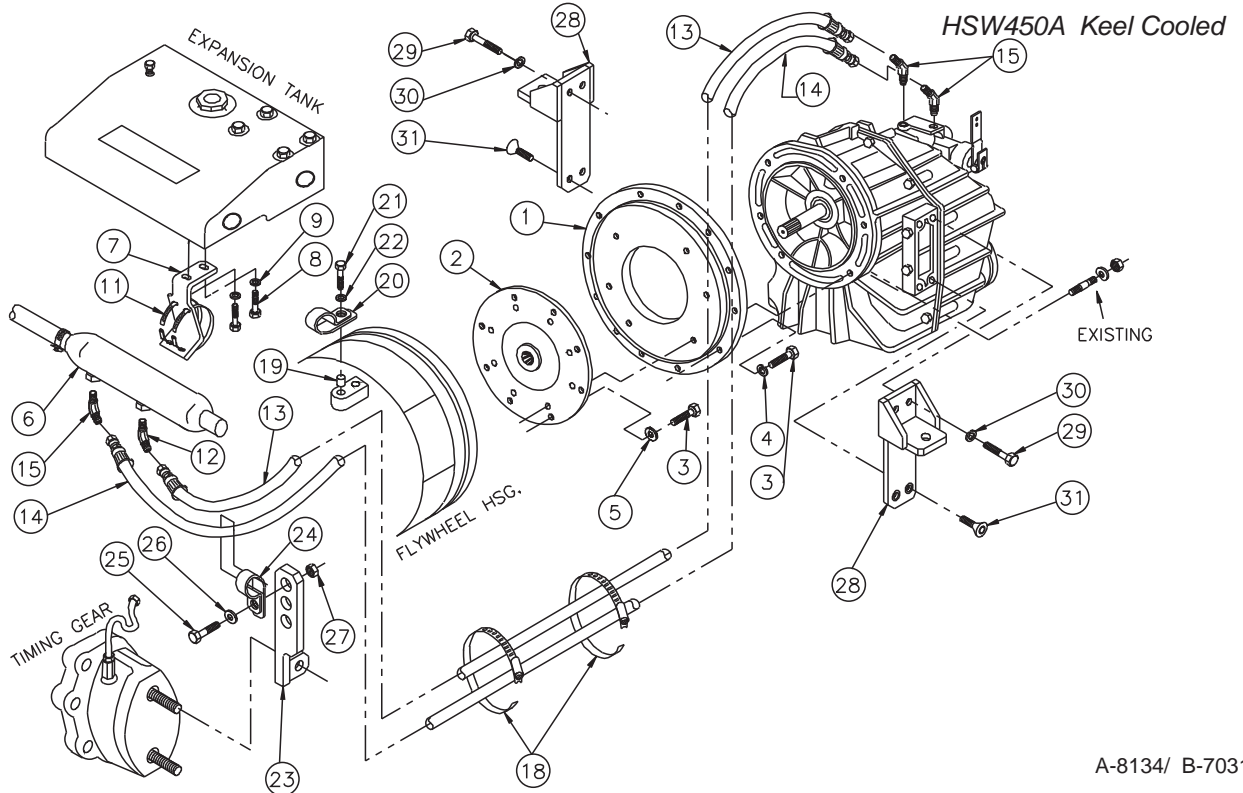

A-8134/ B-7031

KEY	PART NUMBER	QTY	DESCRIPTION	SERIAL NUMBER
1	500-018	1	Adapter SAE #4 x Hurth	-
2	34-61043	1	Drive Damper, Dual Element SAE #10	-
3	12-00312	20	Capscrew, Hex Head 3/8-16 x 1"	-
4	15-00302	12	Lock Washer	-
5	15-00301	8	Flat Washer	-
6	20-65402	1	Gear Oil Cooler	-
7	23-15406	1	Bracket, Gear Oil Cooler Mounting	-
8	12-00209	2	Capscrew, Hex Head 5/6-18 x 3/4"	-
9	15-00211	2	Flat Washer	-
11	19-00020	2	Hose Clamp #20	-
12	12-62508	1	Male Elbow 90° Steel 3/8 NPT x 1/2-37T	-
13	18-65405	1	Hose Assembly, 1/2" ID x 46"	-
14	18-65406	1	Hose Assembly, 1/2" ID x 51"	-
15	21-71009	3	Male Elbow, 45°, Steel 3/8 NPT x 1/2-37T	-
17	18-12254	1	Hose, 1-1/2" ID x 2-1/2" (not shown)	-
18	19-00024	2	Hose Clamp #24	-
19	21-21004	1	Spacer	-
20	19-00000	2	Adelle Clamp	-
21	12-00953	1	Capscrew, Hex Head M12 x 1.75 x 30 mm	-
22	15-00007	1	Flat Washer	-
23	23-62516	1	Bracket, Plumbing Support	-
24	19-71031	1	Adelle Clamp	-
25	12-00809	1	Capscrew, Hex Head M10 x 1.25 x 25 mm	-
26	15-00805	1	Flat Washer	-
27	14-00812	1	Hex Nut, Nylock	-
28	23-65405	2	Bracket, Gear Mounting	-
29	12-00954	4	Capscrew, Hex Head M12 x 1.75 x 35 mm	-
30	15-00912	4	Lock Washer	-
31	12-10914	4	Capscrew, Flat Head Socket, M12 x 1.75 x 35 mm	-

GROUP 8 – FRAME & MOUNTING

Base Frame

361 - 363 Generators

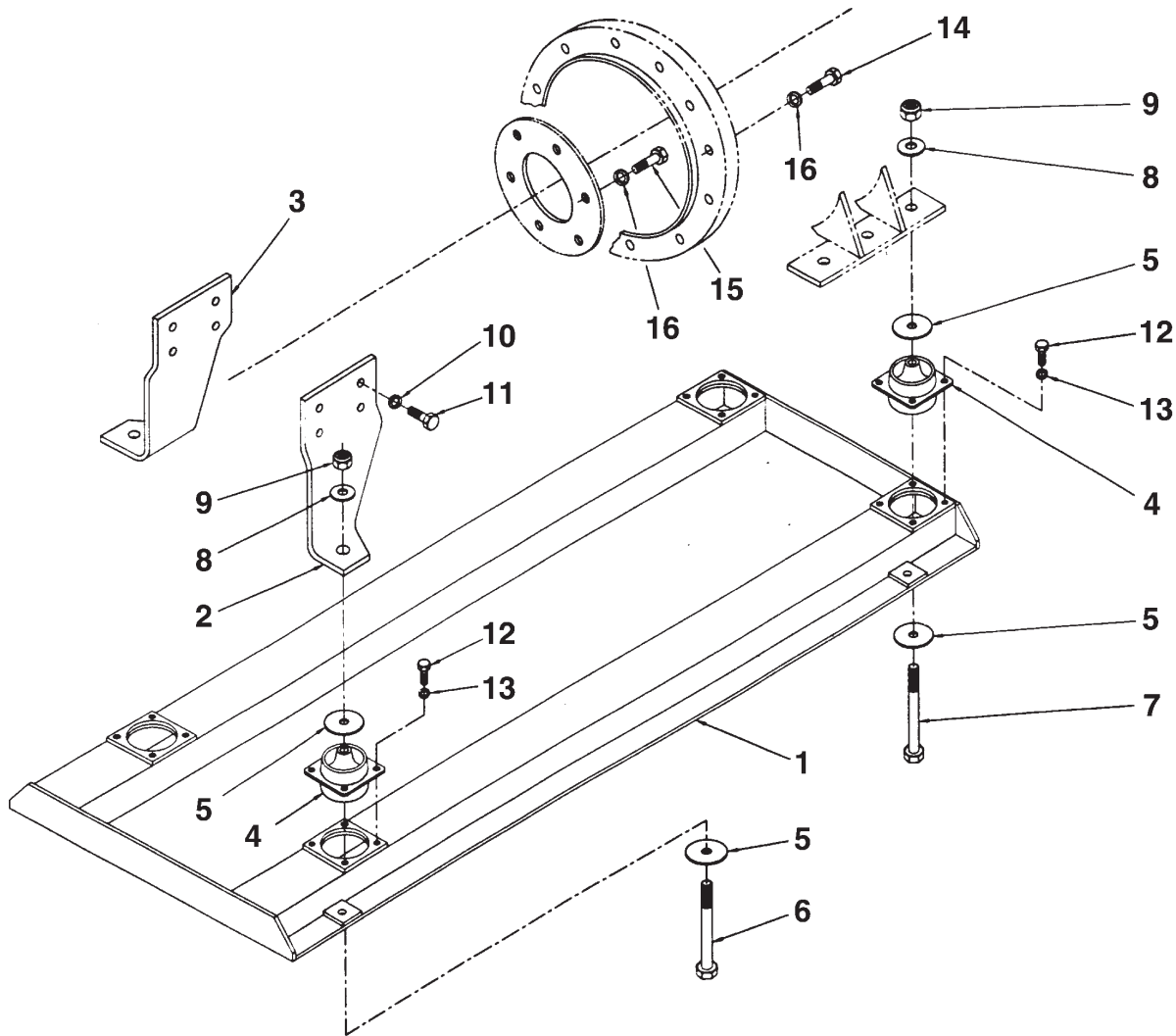

A-7476 / D-2917

KEY	PART NUMBER	QTY	DESCRIPTION	SERIAL NUMBER
1	39-85422	1	Base Frame, Steel	-
	39-85423	1	Base Frame, Aluminum	-
2	23-85418	1	Engine Mounting Bracket, Left Hand	-
3	23-85419	1	Engine Mounting Bracket, Right Hand	-
4	33-83106	4	Mount, Platform 310 lb.	-
5	15-00020	8	Snubbing Washer	-
6	12-00500	2	Capscrew, Hex Head 1/2-13 x 4"	-
7	12-00024	2	Capscrew, Hex Head 1/2-13 x 4-1/2"	-
8	15-00504	4	Flat Washer 1/2 SAE	-
9	14-00512	4	Hex Nut, Nylock 1/2-13	-
10	15-00802	8	Lock Washer, Helical M10	-
11	12-00809	8	Capscrew, Hex Head M10 x 1.25 x 25 mm	-
12	12-00776	16	Capscrew, Hex Head M8 x 1.25 x 20 mm S/S	-
13	15-00705	16	Lock Washer, Helical M8 S/S	-
14	12-00313	12	Capscrew, Hex Head 3/8-16 x 1-1/4"	-
15	23-00311	8	Capscrew, Hex Head 3/8-16 x 3/4"	-
16	15-00302	20	Lock Washer, Helical 3/8"	-

Base Frame

PX-332K1 & K2 Generators

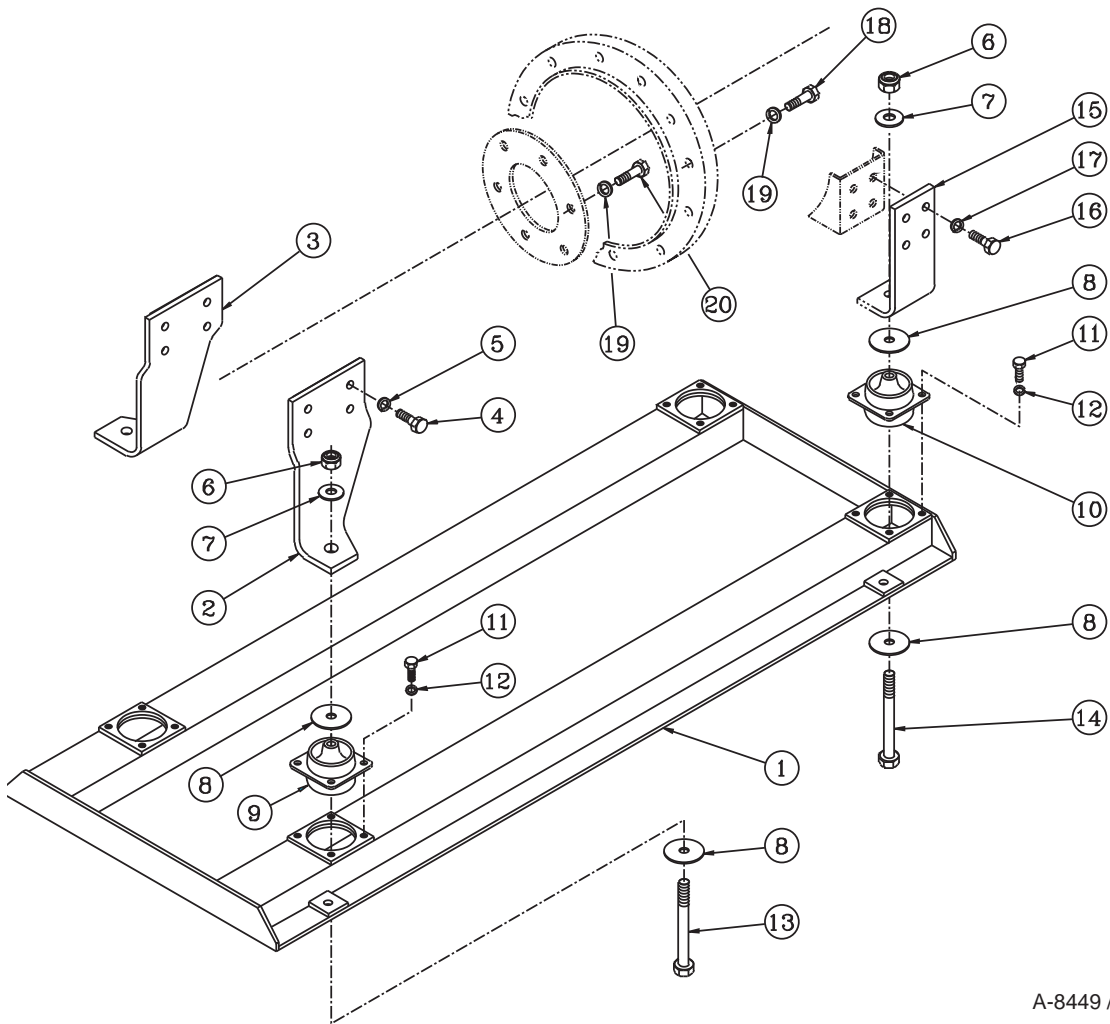

A-8449 / D-3149

KEY	PART NUMBER	QTY	DESCRIPTION	SERIAL NUMBER
1	39-85422	1	Base Frame, Steel, Platform Mounts	-
2	23-85418	1	Front Engine Mounting Bracket, LH	-
3	23-85419	1	Front Engine Mounting Bracket, RH	-
4	12-00809	8	Capscrew, Hex Head M10 x 1.25 x 25 mm	-
5	15-00802	8	Lock Washer, Helical M10	-
6	14-00501	3	Hex Nut, Nylock 1/2-13 Stainless Steel	-
7	15-00508	4	Flat Washer 1/2 SAE Stainless Steel	-
8	15-00020	8	Snubbing Washer	-
9	33-85406	2	Platform Mount, 400 lb.	-
10	33-83106	2	Platform Mount, 310 lb.	-
11	12-00776	16	Capscrew, Hex Head M8 x 1.25 x 20 mm Stainless Steel	-
12	15-00705	16	Lock Washer, Helical M8 Stainless Steel	-
13	12-09500	2	Capscrew, Hex Head 1/2-13 x 4" Stainless Steel	-
14	12-09500	2	Capscrew, Hex Head 1/2-13 x 4" Stainless Steel	-
15	23-65413	2	Generator Support Bracket	-
16	12-00711	8	Capscrew, Hex Head M8 x 1.25 x 20 mm	-
17	15-00702	8	Lock Washer, Helical M8	-
18	12-00313	12	Capscrew, Hex Head 3/8-16 x 1-1/4"	-
19	15-00302	20	Lock Washer, Helical 3/8	-
20	12-00313	8	Capscrew, Hex Head 3/8-16 x 1-1/4"	-

GROUP 8 – FRAME & MOUNTING

Base Frame

M30C, M30CS, and M32C Commercial Marine Units with 224 Generator

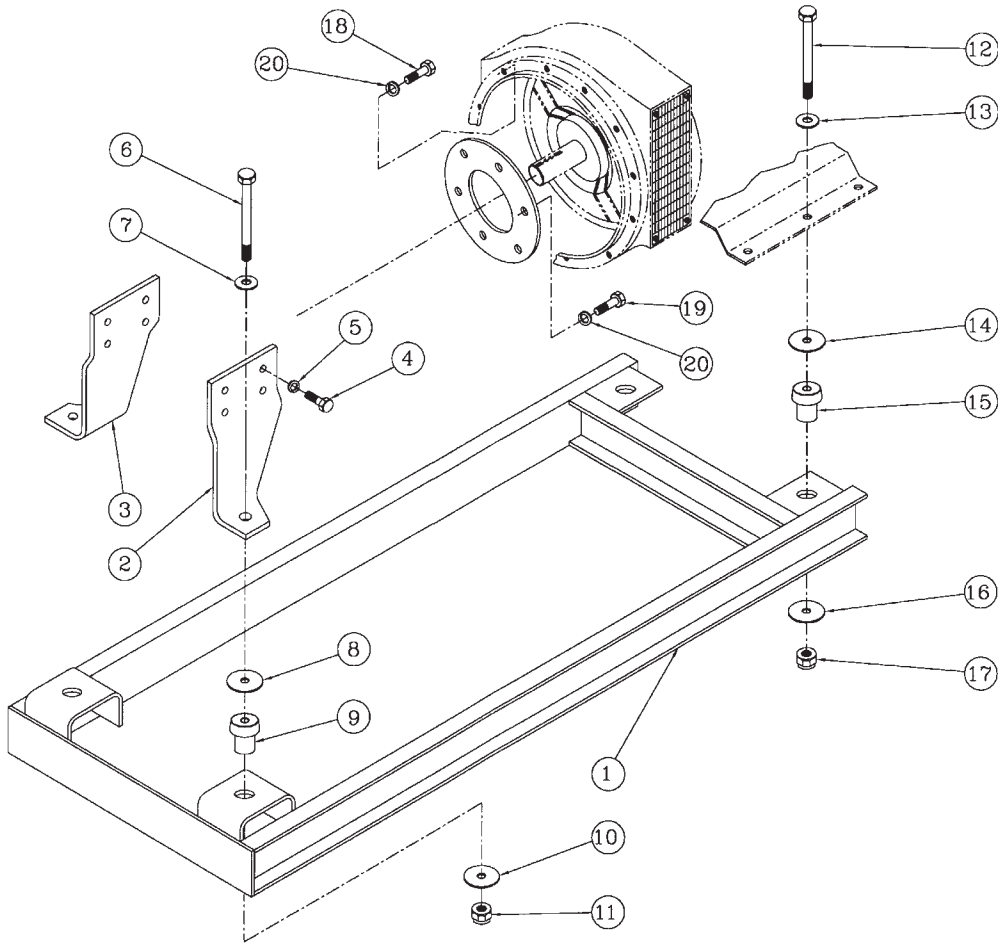

A- 6696, A-7741 / D-2918

KEY	PART NUMBER	QTY	DESCRIPTION	SERIAL NUMBER
1	39-85421	1	Base Frame	-
2	23-85411	1	Front Engine Mounting Bracket, Left Hand	-
3	23-85412	1	Front Engine Mounting Bracket, Right Hand	-
4	12-00809	8	Capscrew, Hex Head M10 x 1.25 x 25 mm	-
5	15-00802	8	Lock Washer, Helical M10	-
6	12-00550	2	Capscrew, Hex Head 1/2-13 x 3"	-
7	15-00504	2	Flat Washer 1/2 SAE	-
8	15-00016	2	Head Washer	-
9	33-81054	2	Centerbonded Mount, 400 lb.	-
10	15-00026	2	Tail Washer	-
11	14-00512	2	Hex Nut, Nylock 1/2-13	-
12	12-00550	2	Capscrew, Hex Head 1/2-13 x 3"	-
13	15-00504	2	Flat Washer 1/2 SAE	-
14	15-00016	2	Head Washer	-
15	33-81054	2	Centerbonded Mount, 400 lb.	-
16	15-00026	2	Tail Washer	-
17	14-00512	2	Hex Nut, Nylock 1/2-13	-
18	12-00313	12	Capscrew, Hex Head 3/8-16 x 1-1/4"	-
19	12-00311	8	Capscrew, Hex Head 3/8-16 x 3/4"	-
20	15-00302	20	Lock Washer, Helical 3/8"	-

Base Frame

M33C with PX-332K1 Generator

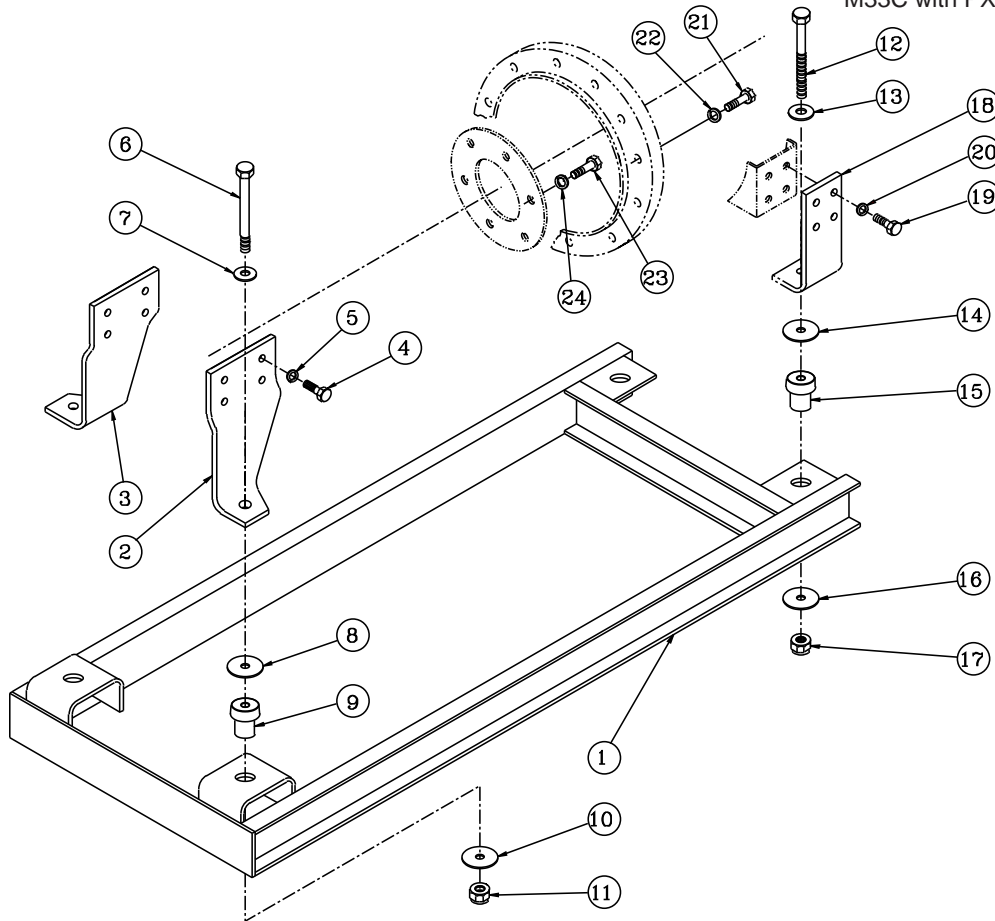

A-9772 / D-3498

KEY	PART NUMBER	QTY	DESCRIPTION	SERIAL NUMBER
1	39-85428	1	Base Frame	-
2	23-85418	1	Front Engine Mounting Bracket, Left Hand	-
3	23-85412	1	Front Engine Mounting Bracket, Right Hand	-
4	12-00809	8	Capscrew, Hex Head M10 x 1.25 x 25 mm	-
5	15-00802	8	Lock Washer, Helical M10	-
6	12-95501	2	Capscrew, Hex Head M12 x 1.75 x 75 mm S/S	-
7	15-09007	2	Flat Washer M12 S/S	-
8	15-00016	2	Head Washer	-
9	33-81054	2	Centerbonded Mount, 400 lb.	-
10	15-00026	2	Tail Washer	-
11	14-09830	2	Hex Nut, Nylock M12 x 1.75 S/S	-
12	12-95501	2	Capscrew, Hex Head M12 x 1.75 x 75 mm S/S	-
13	15-09007	2	Flat Washer M12 S/S	-
14	15-00016	2	Head Washer	-
15	33-81054	2	Centerbonded Mount, 400 lb.	-
16	15-00026	2	Tail Washer	-
17	14-09830	2	Hex Nut, Nylock M12 x 1.75 S/S	-
18	23-65413	2	Bracket, Generator Support LH/ RH	-
19	12-00711	8	Capscrew, Hex Head M8 x 1.25 x 20 mm	-
20	15-00702	8	Lock Washer, Helical M8	-
21	12-00313	12	Capscrew, Hex Head 3/8 -16 x 1 -1/4"	-
22	15-00302	12	Lock Washer, Helical 3/8	-
23	12-00313	8	Capscrew, Hex Head 3/8 -16 x 1 -1/4"	-
24	15-00302	8	Lock Washer, Helical 3/8	-

Front Engine Mounts

Lugger Application

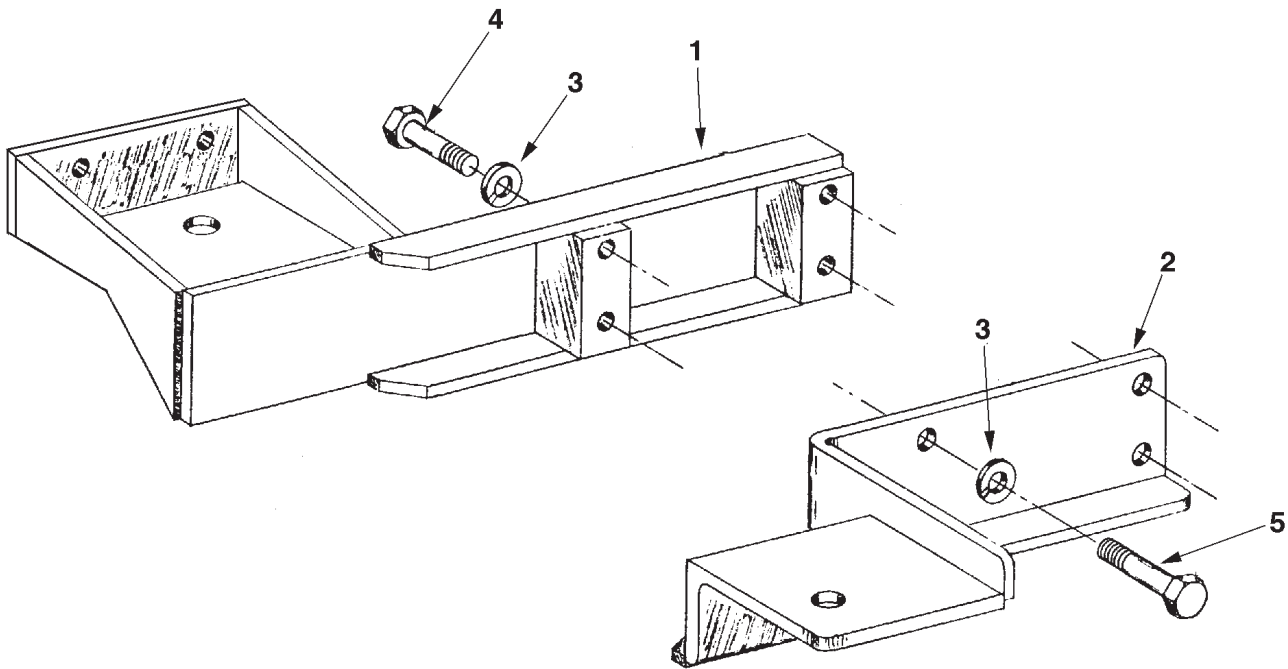

A-7867

KEY	PART NUMBER	QTY	DESCRIPTION	SERIAL NUMBER
1	23-85421	1	Engine Front Mount Bracket, Right Hand	-
2	23-85420	1	Engine From Mount Bracket, Left Hand	-
3	15-00802	8	Lock Washer, Helical M10	-
4	12-00823	4	Capscrew, Hex Head M10 x 1.25 x 55 mm	-
5	12-00809	4	Capscrew, Hex Head M10 x 1.25 x 25 mm	-

Lifting Eye - Front

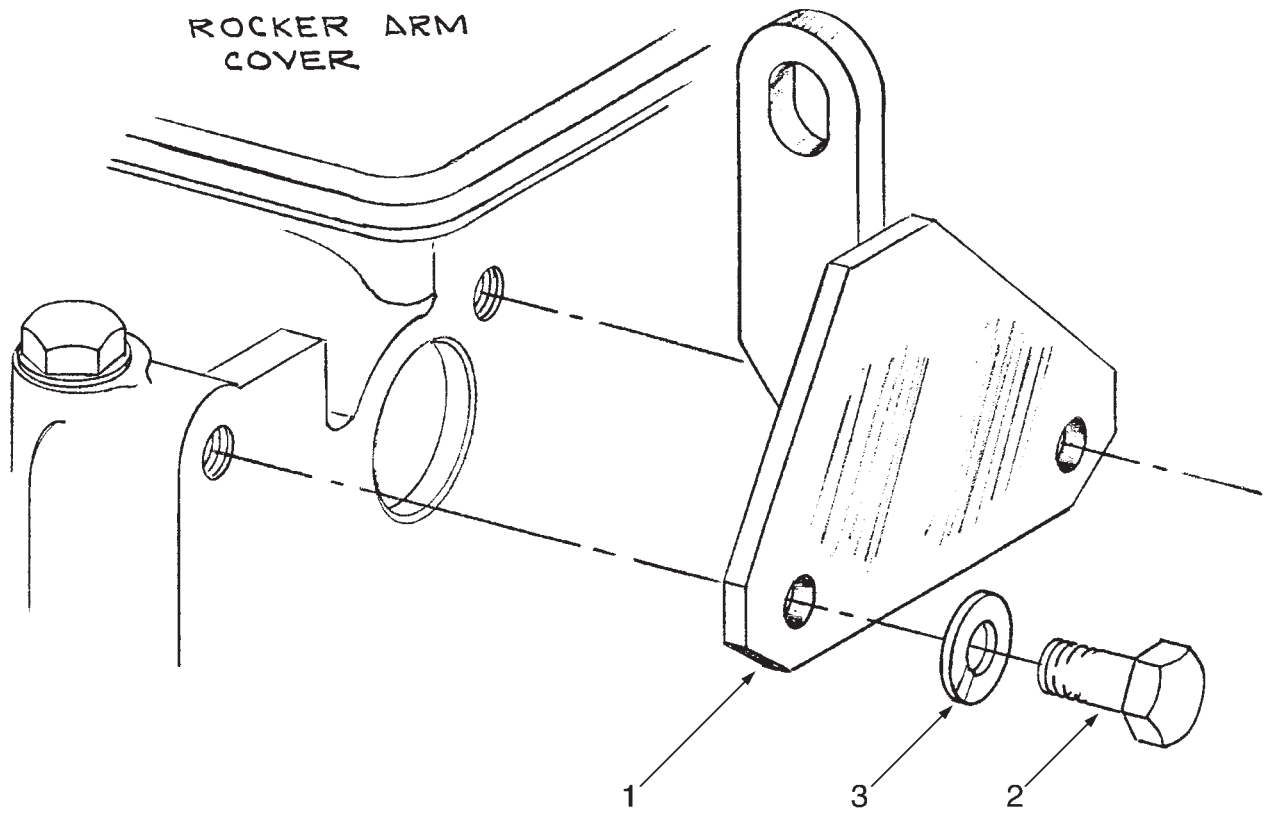

A-4542

KEY	PART NUMBER	QTY	DESCRIPTION	SERIAL NUMBER
1	00-75401	1	Lifting Eye, Front	-
2	12-00808	2	Capscrew, Hex Head M10 x 1.25 x 20 mm	-
3	15-00802	2	Lock Washer, Helical M10	-

P.T.O. Adapter

Marine - Early Production & M32C with 224 Frame Generator

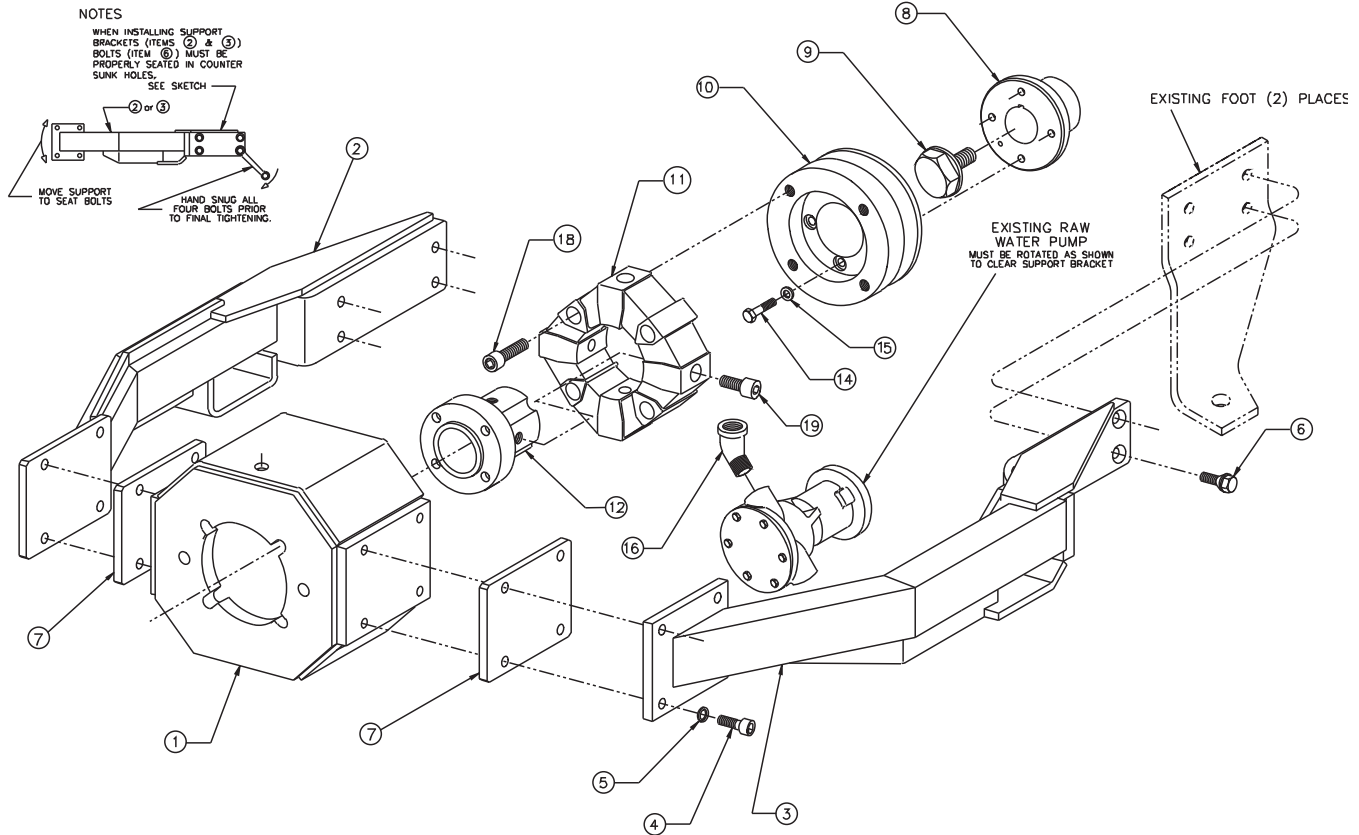

A-6290 / D-2588C

KEY	PART NUMBER	QTY	DESCRIPTION	SERIAL NUMBER
1	10-65401	1	Housing	-
2	23-65402	1	Bracket	-
3	23-65403	1	Bracket	-
4	12-34803	8	Capscrew, Socket Head M10 x 1.5 x 25 mm	-
5	15-00803	8	Lock Washer, Hi-Collar M10	-
6	12-65402	8	Capscrew, Hex Head W/Tapered Seat M10 x 1.25 x 28 mm	-
7	28-65401	2	Spacer Plate	-
8	34-65402	1	Flange, Pulley Mounting	-
9	90105-16951-71	1	Capscrew Adapter Flange Retainer	-
10	34-65405	1	Pulley, PTO Drive	-
11	34-65406	1	Coupling Assembly	-
12	34-65407	1	Hub	-
14	12-00712	8	Capscrew, Hex Head M8 x 1.25 x 25 mm	-
15	15-00701	8	Flat Washer M8	-
16	21-00128	1	St. Elbow 45, Brass 1/2NPT x 1/2NPT	-
17	32-60001	4	Taper Pin #4 x 1" (not shown)	-
18	12-20914	4	Capscrew, Socket Head M12 x 1.75 x 35 mm	-
19	12-20920	4	Capscrew, Socket Head M12 x 1.75 x 40 mm	-

P.T.O. Adapter

Marine - Late Production & M32CR

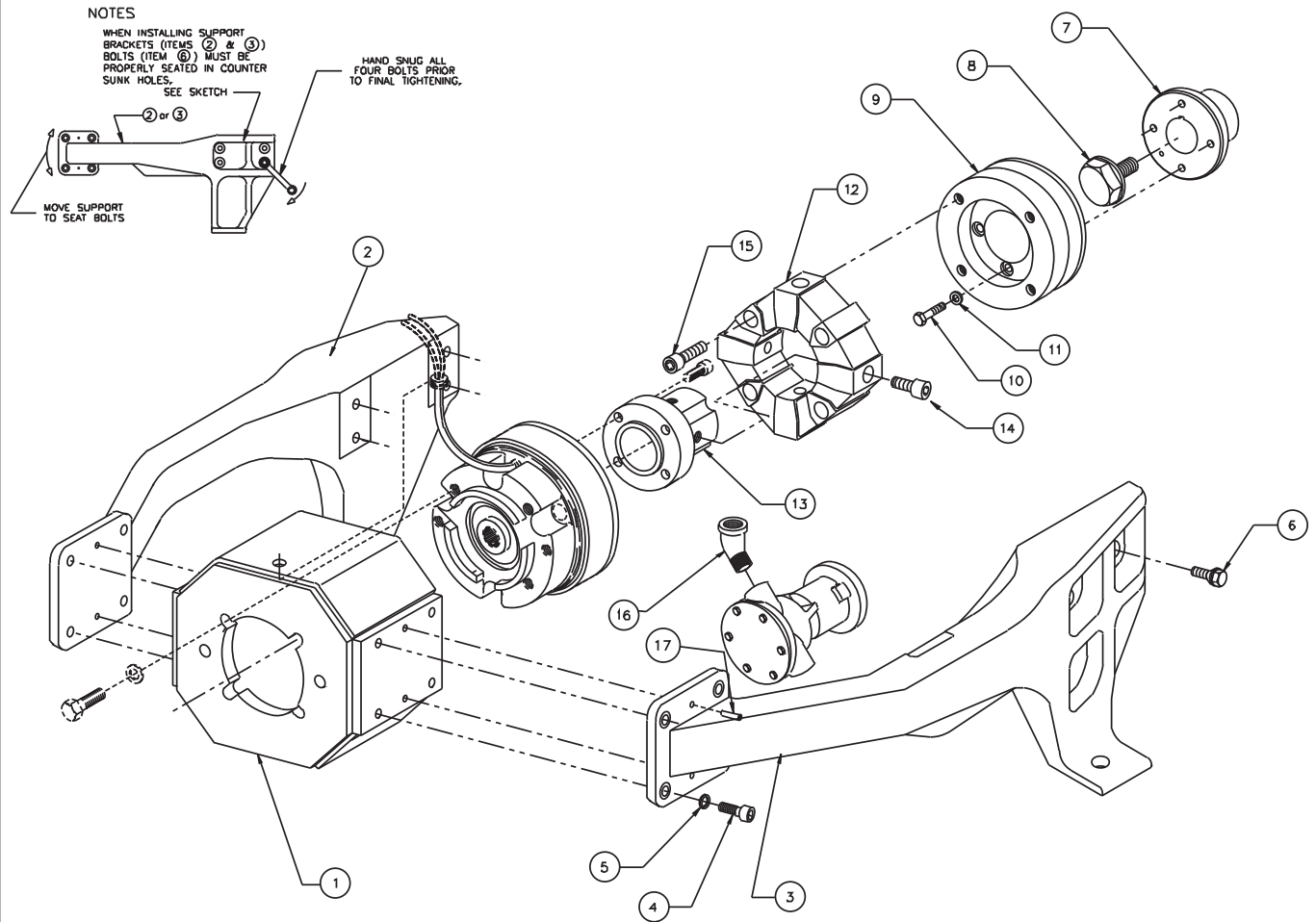

A-7731A / D-3155A

KEY	PART NUMBER	QTY	DESCRIPTION	SERIAL NUMBER
1	10-65401	1	PTO Clutch Housing	-
2	23-65414	1	Engine/PTO Support Bracket (Right Hand, formerly 23-65404)	-
3	23-65416	1	Engine/PTO Support Bracket (Left Hand, formerly 23-65406)	-
4	12-34803	8	Capscrew, Socket Head M10 x 1.5 x 25 mm	-
5	15-00803	8	Lock Washer, Hi-Collar M10	-
6	12-65401	8	Capscrew, Hex Head with Tapered Seat M10 x 1.25 x 20 mm	-
7	34-65402	1	Pulley Mounting Flange	-
8	90105-16951-71	1	Crankshaft Adapter Flange Retainer Capscrew	-
9	34-65405	1	PTO Drive Pulley	-
10	12-00712	4	Capscrew, Hex Head M8 x 1.25 x 25 mm	-
11	15-00701	4	Flat Washer M8	-
12	34-65406	1	Coupling Assembly	-
13	34-65407	1	Hub	-
14	12-20920	4	Capscrew, Socket HD M12 x 1.75 x 40 mm	-
15	12-20914	4	Capscrew, Socket HD M12 x 1.75 x 35 mm	-
16	21-00128	1	Street Elbow 45°, Brass 1/2NPT x 1/2NPT	-
17	32-60001	4	Taper Pin #4 x 1"	-

Electric Clutch

12 Volt and 24 Volt H-28 B-Spline

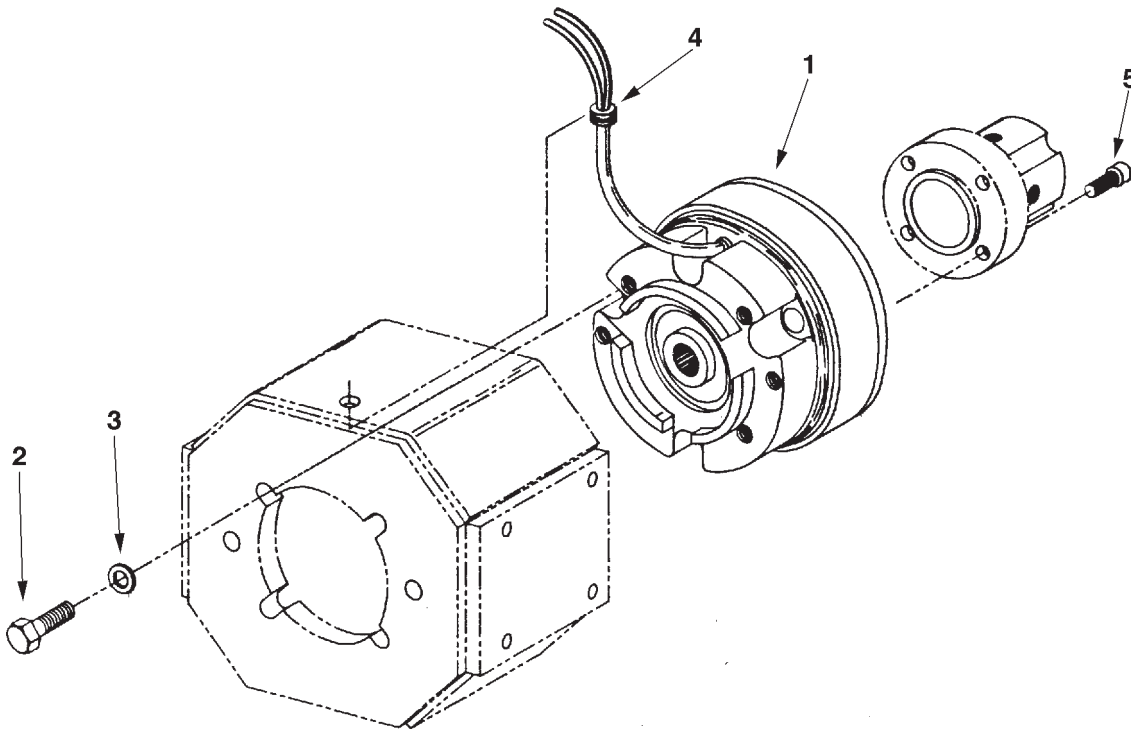

A-6291 + A-6346 / C-3020

KEY	PART NUMBER	QTY	DESCRIPTION	SERIAL NUMBER
1	34-60031	1	Electric Clutch Assembly (12 volt)	-
	34-60032	1	Electric Clutch Assembly (24 volt)	-
2	12-00513	4	Capscrew, Hex Head 1/2-13 x 1-1/4	-
3	15-00007	4	Flat Washer M12	-
4	00-61003	1	Grommet	-
5	12-63800	4	Capscrew, Socket Head 3/8-24 x 3/4	-

Oil Drain Kit

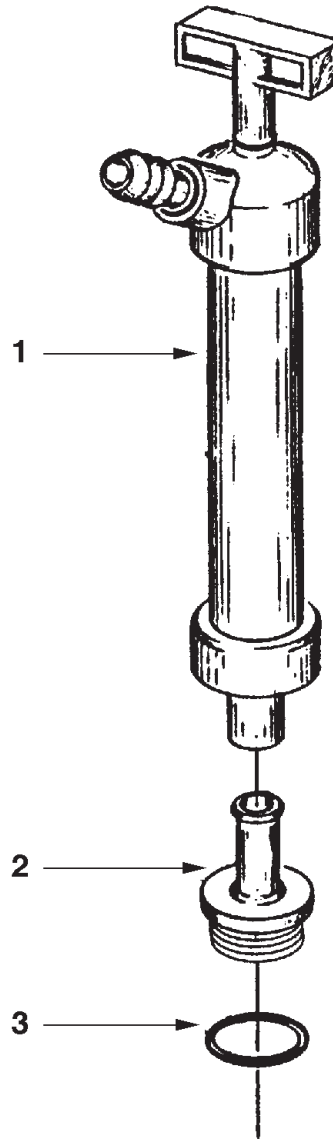

A-5024 / B-3990

KEY	PART NUMBER	QTY	DESCRIPTION	SERIAL NUMBER
••	34-70010		Oil Drain Kit Complete (includes all keys)	-
1	36-72002	1	Hand Pump	-
2	31-70001	1	Adapter, Oil Drain	-
3	16-70001	1	O-Ring	-

Low Oil Level Switch/Gauge

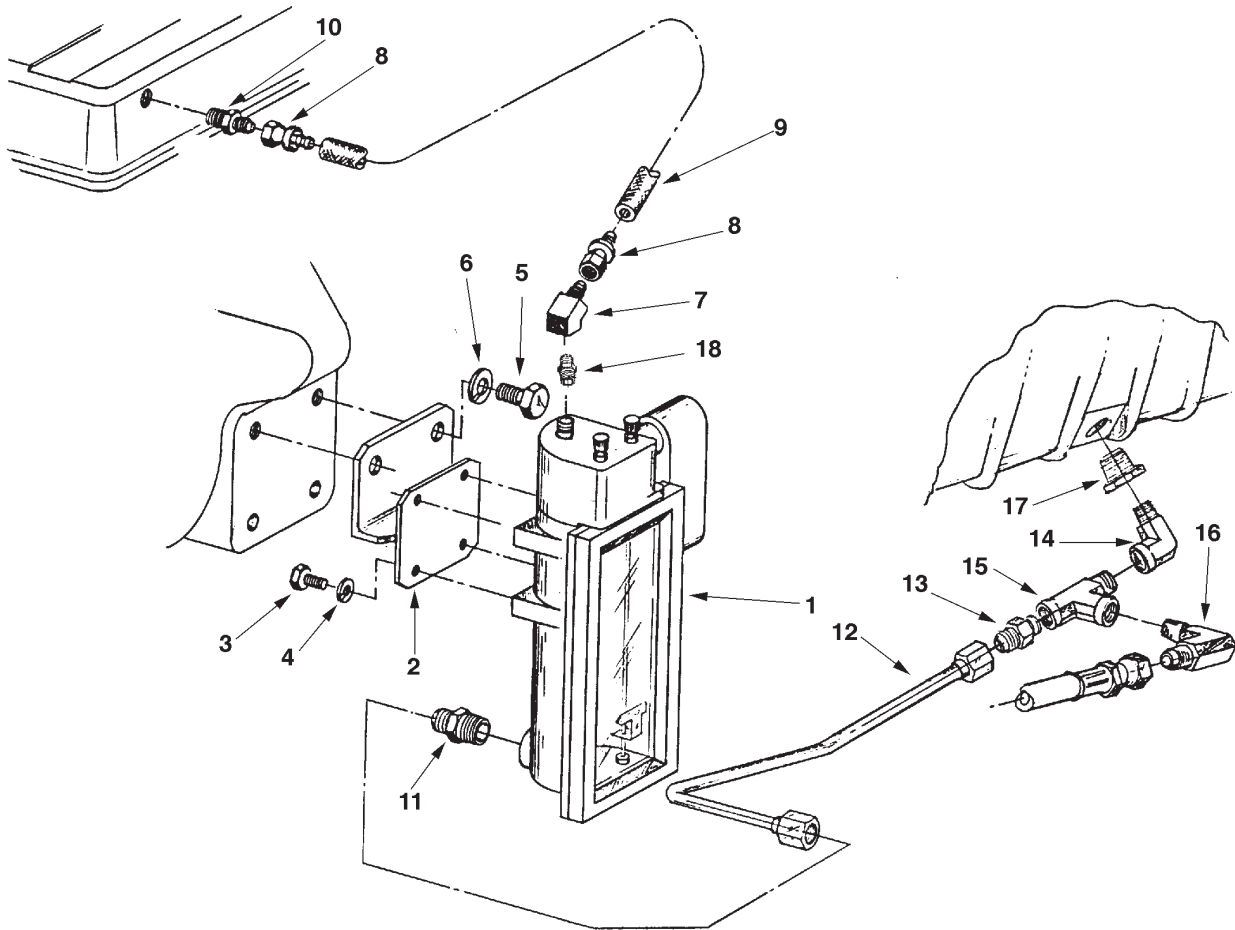

A-4361B / C-2373

KEY	PART NUMBER	QTY	DESCRIPTION	SERIAL NUMBER
1	22-10004	1	Oil Level Switch/Gauge, Isolated Ground	-
2	23-75402	1	Mounting Bracket	-
3	12-00100	4	Capscrew, Hex Head 1/4-20 x 1/2"	-
4	15-00102	4	Lock Washer, Helical 1/2"	-
5	12-00512	2	Capscrew, Hex Head 1/2-13 x 1"	-
6	15-00502	2	Lock Washer, Helical 1/2"	-
7	21-54801	1	Male Elbow 45 1/4 NPT x 1/4-37T	-
8	21-50009	2	Female Swivel, Brass 1/4-37T x 1/4 HB	-
9	18-53601	1	Hose, 1/4" ID x 29" Push-on	-
10	21-74406	1	Male Connector, Steel 1/4 NPT x 1/4-37T	-
11	21-51001	1	Male Connector, Steel 1/2 NPT x 1/4-37T	-
12	27-05404	1	Tube Assembly	-
13	21-52800	1	Male Connector, Steel 3/8 NPT x 3/8-37T	-
14	21-62506	1	Elbow Street 90° 3/8 NPT x 3/8 NPT	-
15	21-01001	1	Street Tee 3/8 NPT	-
16	21-62508	1	Male Elbow 90° Steel 3/8 NPT x 1/2-37T	-
17	36-75402	1	Bushing M25 x 1.5 3/8 NPT	-
18	21-00002	1	Hex Coupling, Brass 1/8 NPT	-
19	00-40016	1	Grommet (not shown)	-

Water Level Switch/Gauge

Tank Mounted

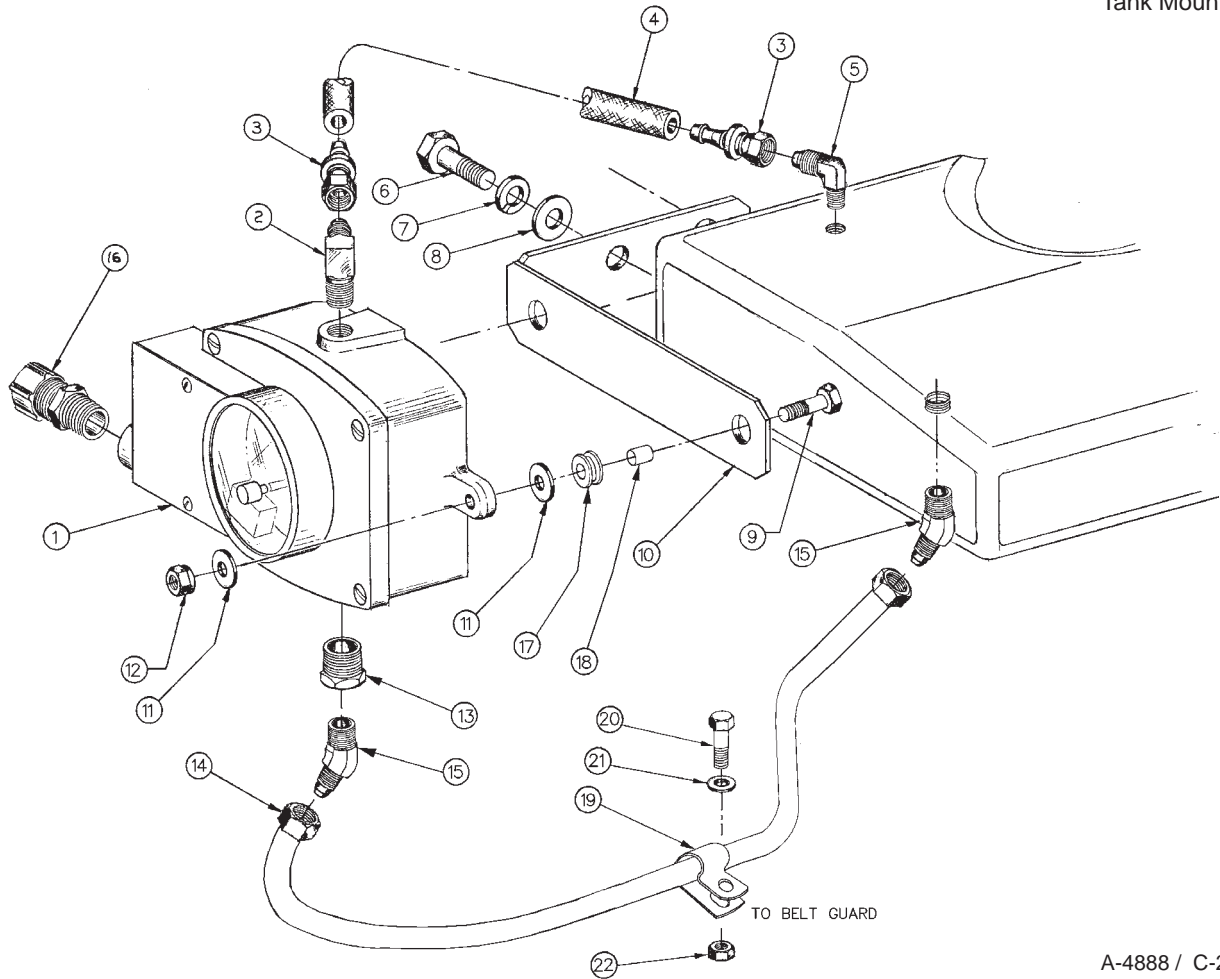

A-4888 / C-2515A

KEY	PART NUMBER	QTY	DESCRIPTION	SERIAL NUMBER
1	22-10003	1	Coolant Level Switch Gauge, Isolated Ground	-
2	21-71044	1	Male Elbow, 90° Brass 1/4 NPT x 1/4-45T	-
3	21-71045	2	Female Swivel, Brass 1/4-45T x 1/4 HB	-
4	18-51007	1	Hose, 1/4" ID x 8" Push-On	-
5	21-71043	1	Male Elbow, 90° Brass 1/8 NPT x 1/4-45T	-
6	12-00311	2	Capscrew, Hex Head 3/8 - 16 x 3/4"	-
7	15-00302	2	Lock Washer, Helical 3/8	-
8	15-00301	2	Flat Washer 3/8	-
9	12-00113	2	Capscrew, Hex Head 1/4 - 20 x 1 1/4"	-
10	23-75409	1	Bracket, Switch Gauge Mounting	-
11	15-70003	4	Snubbing Washer	-
12	14-00112	2	Nylock Hex Nut, 1/4 - 20	-
13	21-00135	1	Bushing, Brass 1/2 NPT x 1/4 NPT	-
14	18-15408	1	Hose Assembly 1/4" ID x 15"	-
15	21-05404	2	Male Elbow, 45° Steel 1/4 NPT x 1/4 - 37T	-
16	00-40016	1	Strain Relief Connection	-
17	00-41074	2	Grommet	-
18	21-15014	2	Sleeve	-
19	19-43201	1	Adelle Clamp	-
20	12-01131	1	Capscrew, Hex Head M6 x 1.0 x 20 mm	-
21	15-00008	1	Flat Washer M6	-
22	14-04803	1	Hex Nut, Nylock M6 x 1.0	-

Pre-Alarm Switches

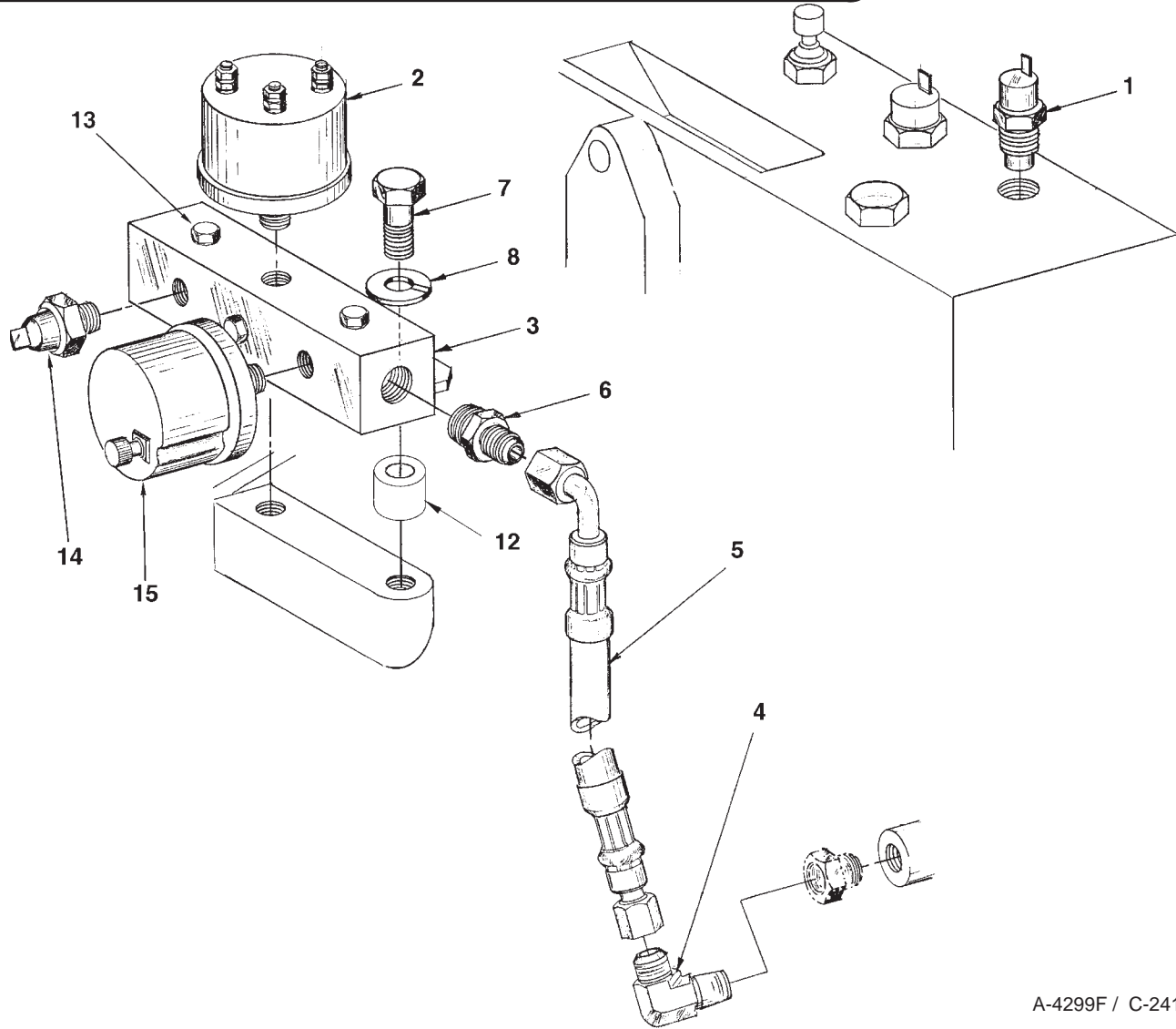

A-4299F / C-2415B

KEY	PART NUMBER	QTY	DESCRIPTION	SERIAL NUMBER
1	22-40907	1	Engine Temperature Switch, 205°F	-
2	22-40901	1	Oil Pressure Switch, 25PSI	-
3	10-85401	1	Oil Pressure Manifold	-
4	21-71053	1	Elbow 90° Steel 1/8 NPT x 1/4-37T	-
5	18-05401	1	Hose Assembly	-
6	21-74406	1	Male Connector, Steel 1/4 NPT x 1/4-37T	-
7	12-00513	2	Capscrew, Hex Head 1/2-13 x 1-1/4"	-
8	15-00502	2	Lock Washer, 1/2	-
9	22-41077	1	Terminal Strip	-
10	12-00005	2	Machine Screw, BH Slotted #8-32 x 3/4"	-
11	14-00003	2	Hex Nut, Nylock #8-32	-
12	21-42206	2	Spacer	-
13	21-00012	3	Plug, Hex Head, Brass 1/8 NPT	-
14		1	Oil Pressure Switch	-
15		1	Oil Pressure Sender } See Electrical System	-
<p>Note: #9 to 11 Terminal Strip & Fasteners not shown (mounted in J-box).</p>				

Raw Water Flow Switch

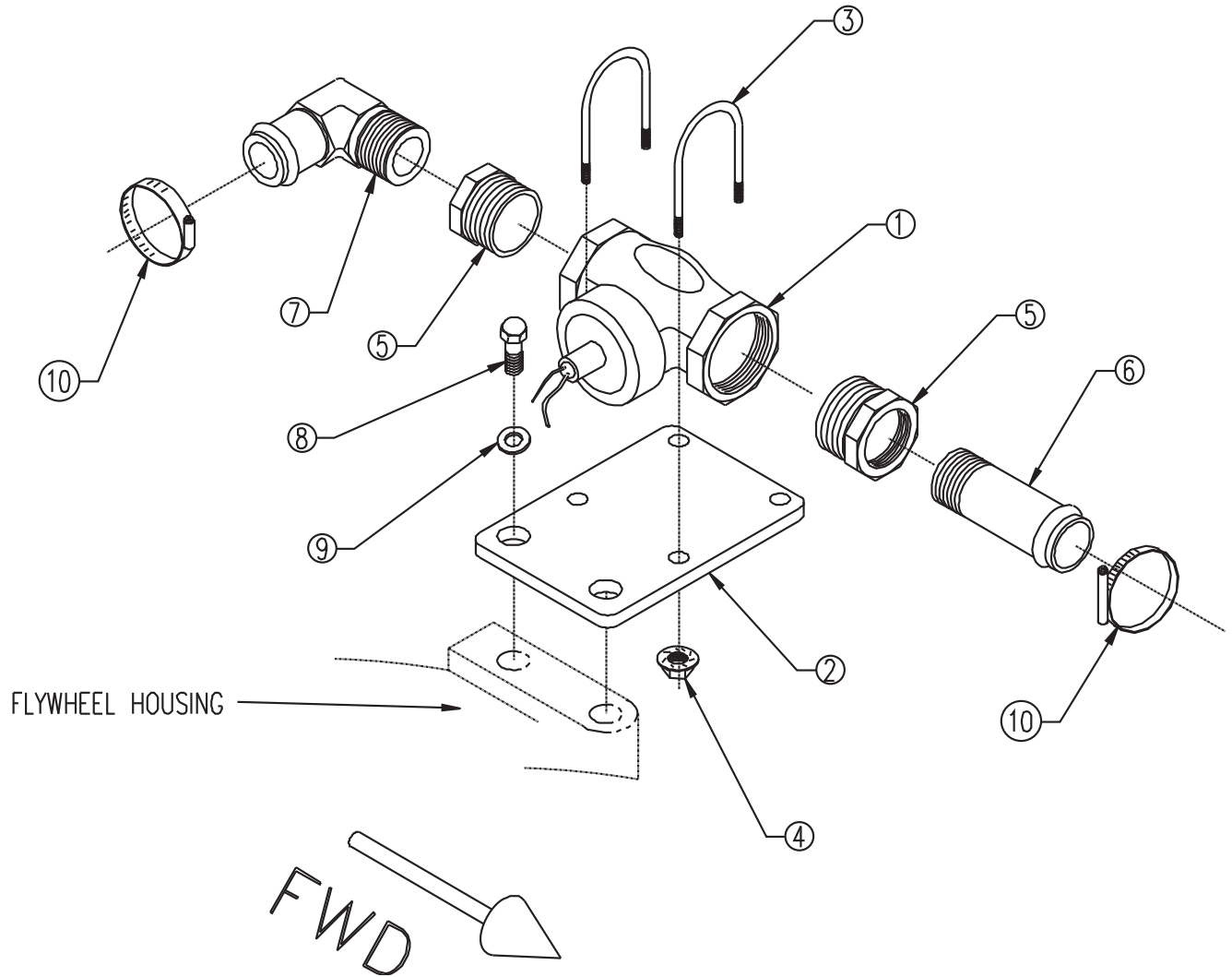

A-7560 / C-4560

KEY	PART NUMBER	QTY	DESCRIPTION	SERIAL NUMBER
1	37-15401	1	Flow Switch	-
2	23-15405	1	Bracket, Flow Switch Mounting	-
3	19-11001	2	U-Bolt Clamp	-
4	14-00101	4	Lock Nut	-
5	21-10023	2	Bushing, Brass 1" NPT x 3/4" NPT	-
6	21-11902	1	Male Connector, Brass 3/4 NPT x 3/4 HB	-
7	21-12809	1	Male Elbow, 90°, Brass 3/4 NPT x 3/4 HB	-
8	12-00512	2	Capscrew, Hex Head 1/2-13 x 1"	-
9	15-00502	2	Lock Washer, Helical 1/2"	-
10	19-00020	2	Hose Clamp #20	-



4420 14th Ave. NW., Seattle WA 98107

Tel: (206) 789-3880 • 1-800-762-0165 • Fax: (206) 782-5455

Northern Lights and Lugger are registered trademarks of Northern Lights, Inc.

© 2005 All rights reserved. Litho USA.