

Installation for 4-1/2 in. (114 mm) dial Size Level Murphygage® and Swichgagage® instruments

00-02-0178
Rev. 2012-06-21
Section 15



Models: OPLHG, OPLHAGS, OPLHFG, OPLHAFGS, OPLHGE, OPLHAGES, OPLHC, OPLHACS, OPLHFC, OPLHAFCS, OPLHCE, OPLHACES, OPLHBP, OPLHABPS, OPLHBPE, OPLHABPES

Please read the following instructions before installing. A visual inspection is recommended before mounting. General Information and these installation instructions are intended for all 4-1/2 in. (114 mm) dial level models.

WARNING

BEFORE BEGINNING INSTALLATION OF THIS MURPHY PRODUCT

- 4 Disconnect all electrical power to the machine.
- 4 Make sure the machine cannot operate during installation.
- 4 Follow all safety warnings of the machine manufacturer.
- 4 Read and follow all installation instructions.



Selected configurations are third party listed. Consult FWMurphy for details.



OPLHFC



OPLHACS

Description

OPLHC, OPLHCE and OPLHCE Swichgagage instruments use a bronze bourdon (C-Tube) tube sensing element. All feature adjustable high and low limit contacts that close to common to operate a shutdown, alarms, automation processes, etc. Model OPLHC has a flange case for wall or surface mounting. Models OPLHFC and OPLHCE are for panel mounting. Sensing is 1/4 NPT male.

OPLHACS, OPLHAFCS and OPLHACES Swichgagage instruments use a 300 series stainless steel port and bellows as the sensing element. All have the same adjustable contact arrangement as the OPLHC family. OPLHACS has a flanged case for wall or surface mounting. Models OPLHAFCS and OPLHACES are for panel mounting. Sensing is 1/4 NPT female.

OPLHBP, OPLHABPS, OPLHBPE, and OPLHABPES are the same as OPLHC and OPLHACS families and include a built-in latching relay available for 12 VDC, 24 VDC, 24 VAC or 120 VAC. Suitable for “on/off” or “start/stop” control.

OPLHG, OPLHGE, OPLHAGS, OPLHAGES and OPLHAFGS are indicating only (without switch contact) versions of the above models.

Precautions

- Do NOT exceed rated level range.
- Do not use or use teflon tape on connection threads.
- Do not block the inlet orifice with pipe dope/sealant.
- For direct mount into the process, a vertical or ninety degree mounting is recommended.
- Use wrench on shank to tighten or loosen connection.
- Do not overtighten the unit.
- Do not twist case when screwing the unit into the process, this will damage internal components and will void the warranty.
- Use shock mounts as necessary to protect from vibration.

IMPORTANT: Gages are pre-calibrated in feet of static head above gage connection. If gage is installed at an elevation higher or lower than tank bottom the gage pointer must be reset for proper level indication. (See *Adjusting Limit Contacts and Gage Pointer* section, page 3).

Specifications

Case: Die cast aluminum.

Contacts: See typical wiring information (page 4).

Movement: 300 series stainless steel; geared.

Sensing connections:

OPLHG, OPLHFG, OPLHGE, OPLHC, OPLHCE, OPLHFC, OPLHBP, OPLHBPE: 1/4 NPT (male)

OPLHACS, OPLHACES, OPLHAGS, OPLHAGES, OPLHABPS, OPLHABPES, OPLHAFCS, OPLHAFGS: 1/4 NPT (female).

-EX Explosion-proof Case Option: 1/4 NPT (female).

Accuracy: ±2% for the **first** and **last** quarters of the scale, the **middle half** of scale is ±1%.*

Dial: 4-1/2 in. (114 mm), white on black background.

Conduit: Square case: 1/2 NPT, conduit.

Round case: Optional 1/2 NPT male (with “ES” option).

Overrange: Do not exceed 10% above full range.

*Bourdon tube (OPLHC) models in the 20 ft. (6m) range have an accuracy of 3% full scale.

OPLHAC (Bellows) models, 0-5' 3% FS, 0-10' 2% FS

CASE MOUNTING

Wall Mount

Flanged case design intended for wall mount, it can also be direct mounted. Shown with shock mounts (optional).

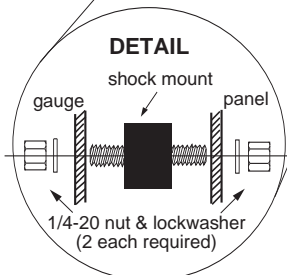
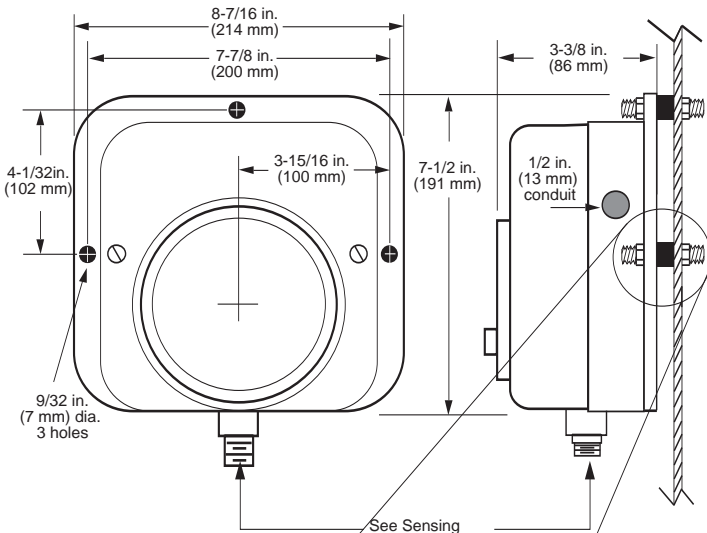

Flush/Panel Mount (round case)

A round case design to be mounted within a panel from 1/32 in. (1 mm) to 1/8 in. (3 mm) thick. It can also be direct mounted.

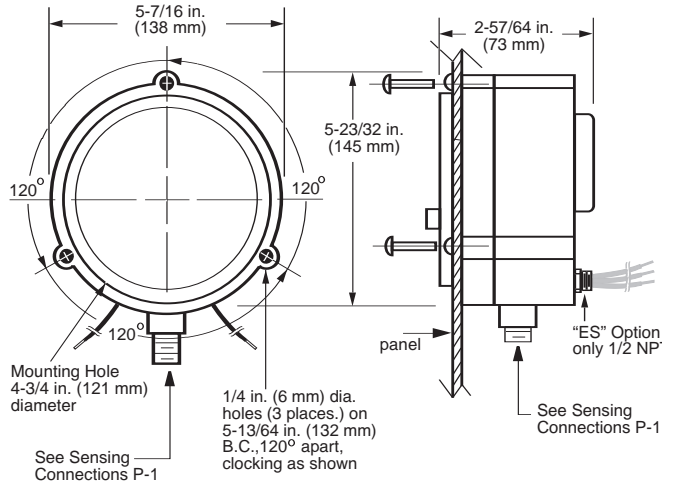

"E" Case Models (square case flush mount)

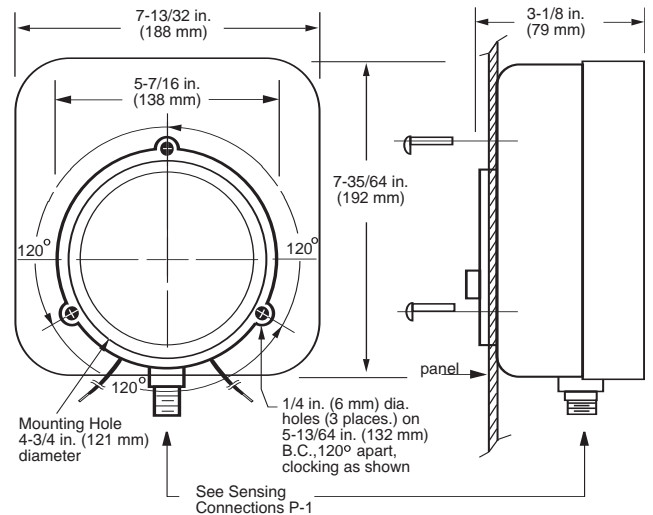

Explosion-proof Case Mount

Explosion-proof case can be mounted from face or rear.

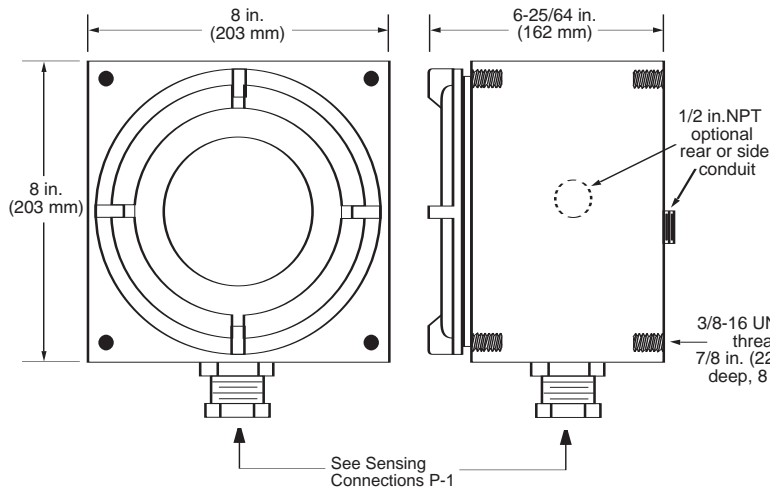

Flush mount/Wall Mount

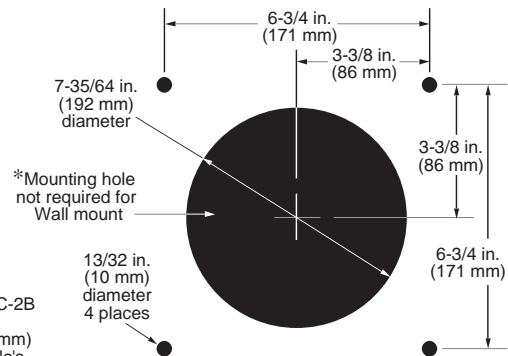

INSTALLATION INSTRUCTIONS AND OPTIONS

IMPORTANT: Gages are pre-calibrated in feet of static head above gage connection. If gage is installed at an elevation higher or lower than tank bottom the gage pointer must be reset for proper level indication. See *Adjusting Limit Contacts and Gage Pointer* section below.

Direct Mount

1. Connection should be made near the bottom of the tank, but above sludge level. See **DETAIL "A"**.
2. The Swichgag connection can be into side or bottom of the tank.
3. After initial installation "stick" tank to determine level and reset pointer to that level. See *Adjusting Limit Contacts and Gage Pointer* section below.

Bubbler System for Above/Underground Tanks

1. Connect a level sensor tube to Swichgag instrument. See **DETAILS "B"** and **"C"**.
2. Keep sensing tubing above sludge level. Keep connections away from a suction line of the pump. A consistent air flow through the tubing is suggested and will increase the accuracy of the unit. A flow control should be used to limit the flow of air. There should be a constant flow of air. Too high of a rate of air flow will cause the reading to have errors showing the tank level to be higher than it is.

NOTE: Minimum pressure regulator setting in psi = maximum Swichgag instrument range in feet of head x conversion factor (example: 0.4335 for fresh water).

3. After initial installation, "stick" tank to determine level and reset pointer to that level. See *Adjusting Limit Contacts and Gage Pointer* section below.

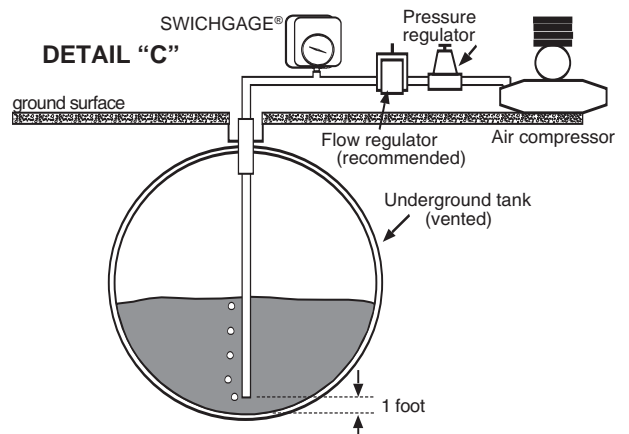
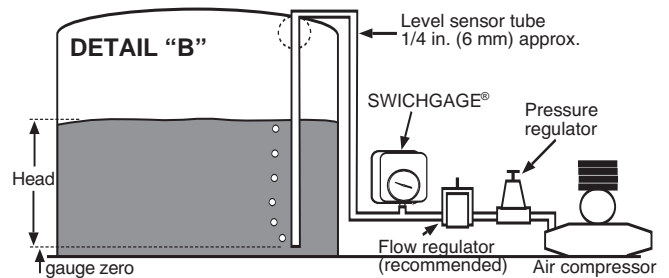
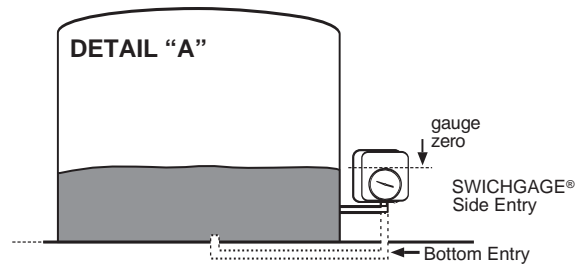

ADJUSTING LIMIT CONTACTS AND GAGE POINTER

Limit Contact Adjustments

Facing the dial, left side knob is "Low limit" contact. "High limit" contact is located next to the right of the "Low" limit contact.

To set limit contact simply turn the fingertip type knob to the desired point on the scale.

Limit Contact Wiping Feature

The force of pointer causes the flexible contact arm (A) to "tilt" resulting in a wiping action (D). This clears away film or corrosion formed on the contact surfaces.

- A. Contact arm-flex
- B. Contact arm
- C. Pointer Contact
- D. Initial point of contact
- E. Limit contact knob

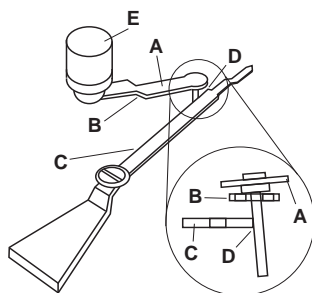

IMPORTANT: To adjust the gage pointer for high or low elevated tanks, subtract the tank elevation from the gage reading to determine the actual tank reading.

Gage Pointer Adjustments

To reset to zero or to a known value proceed as follows:

1. Turn off power. Remove the snap ring and the lens/contact assembly (or open hinged cover).
2. Hold the pointer hub with thumb and forefinger then turn screw to desired point. Avoid touching the gold flashed, silver contact areas. See **DETAIL "A"**.
3. Replace lens contact assembly and snap ring (or close hinged cover), and turn on power.

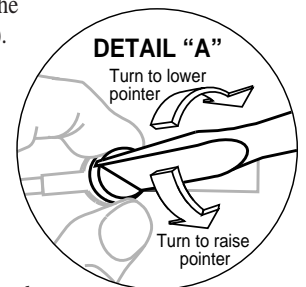

NOTE: Span adjustments and recalibration must be performed by authorized mechanic or return the unit to FWMurphy (see addresses on last page).

OPERATION TEST

FOR ALL MODELS

1. Operational test(s) are performed after the unit is properly installed and wired.
2. When pressure (level) is applied to the instrument, the pointer will travel upscale in a clockwise direction. Adjust the contacts so that neither is touching the pointer.
3. Test each limit contact separately by turning it so that it touches the pointer. This should operate the control circuit or device; Example: start a pump on high tank level and stop it on low tank level.
4. When desired operation is verified, set the adjustable contacts at the low and high levels.

TYPICAL ELECTRICAL DIAGRAMS



CAUTION: Perform the wiring operation with the power source "OFF". Make sure the voltage and current requirements are within the SWICHGAGE® ratings. Before wiring determine voltage and polarity for the application. Use the appropriate wire size. All connections should be made using a spade (forked) or ring terminals. For pigtail connections use wire nuts. Conduit is recommended to protect wires from damage.

OPLHC, OPLHFC, OPLHCE, OPLHACS, OPLHAFCS, OPLHACES

Contact Rating: 1 SPDT, Center Off; 2 A, 30 VDC, 1 A, 125 VAC pilot duty.

SQUARE CASE VERSIONS

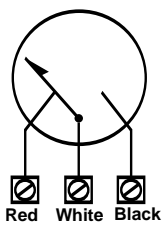

ROUND CASE VERSIONS

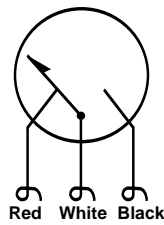

NOTE: Diagrams above show the pointer in the at rest (shelf) position.

Transformer Relay Assemblies

For higher voltages the Murphy TR Assemblies can be used in conjunction with any Switchgauge instrument.

"BP" Versions

Contact Rating: SPDT dry relay contacts, 10 A, 125 VAC.

NOTE: Diagram below shows the pointer in the rest (shelf) position.

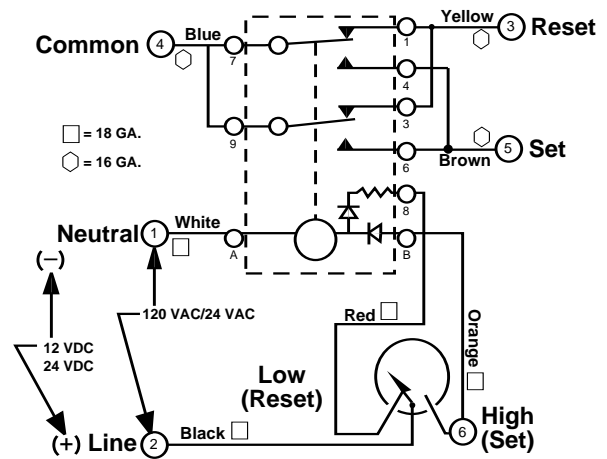

Warranty

A limited warranty on materials and workmanship is given with this FW Murphy product.
A copy of the warranty may be viewed or printed by going to www.fwmurphy.com/support/warranty.htm

FW Murphy
P.O. Box 470248
Tulsa, Oklahoma 74147 USA
+1 918 317 4100 Fax: +1 918 317 4266
E-mail: sales@fwmurphy.com

Industrial Panel Division
Fax: +1 918 317 4124
E-mail: ipdsales@fwmurphy.com

Murphy Power Ignition
Web site: www.murphy-pi.com
Control Systems & Services Division
P.O. Box 1819

Rosenberg, Texas 77471 USA
Phone: +1 281 633 4500 Fax: +1 281 633 4588
E-mail: sales@fwmurphy.com

FRANK W. MURPHY, LTD
Church Rd Laverstock
Salisbury SP1 1QZ UK
Phone: +44 172 241 0055 Fax: +44 172 241 0088
E-mail: sales@fwmurphy.co.uk
Web site: www.fwmurphy.co.uk

COMPUTRONIC CONTROLS, LTD
41 - 43 Railway Terrace
Nechells, Birmingham B7 5NG UK
Phone: +44 121 327 8500 Fax: +44 121 327 8501
E-mail: sales@computroniccontrols.com
Web site: www.computroniccontrols.com

www.fwmurphy.com

FW MURPHY INSTRUMENTS (HANGZHOU) CO. LTD
77 23rd Street
Hangzhou Economic & Technological Development Area
Hangzhou, Zhejiang 310018 China
Phone: +86 571 8788 6060 Fax: +86 571 8684 8878

FW MURPHY INTERNATIONAL TRADING (SHANGHAI) CO., LTD.
Suite 1704, Tower B, City Center of Shanghai; 100 Zunyi Road
Shanghai, 200051 China
Phone: +86 21 6237 2082 Fax: +86 21 6237 2083
Web site: mhong@fwmurphy.com



ISO 9001
REGISTERED

Printed in U.S.A.