

Tachometers and Tach/Hourmeters – AT and ATH Series



Features

- 4000 RPM –0 to 100,000 hours
- Sensing from Magnetic Sensor, Battery Charging Alternator or Ignition Signal
- High Visibility Analog Readout
- Air Core Movement
- Easy Calibration through Dip Switches
- Through Dial Lighting
- Powered by 11-28 VDC Battery Available



Products covered by this bulletin comply with European Council electromagnetic compatibility directive 89/336/EEC, except as noted.

The AT Series tachometers are rugged, transistorized instruments with solid-state circuitry for indication of engine RPM. They are equipped with a bracket for mounting into a standard 3- 3/8 in. (86 mm) dash mounting hole. A full 270° sweep of the pointer gives an accurate indication on a large easy-to-read scale and the dial can be illuminated for night reading. The ATH Series models are also equipped with hourmeter to record the elapsed running time of an engine.

Models available for Alternator, Magnetic Sensor or Ignition signal. These instruments are designed to function from pulses generated by an alternator with 4, 8, 12, 14, or 16 poles on the rotor (3 - 40 PPR). The pulses can also be obtained from the ring gear of an engine by means of an **electromagnetic sensor** (magnetic pickup). Murphy's magnetic sensor driven models are designed to function with flywheels having anywhere from 50 to 304 teeth. **Ignition signal** model available for 2 - 10 cylinder, 4 cycle spark-ignited engines. All models are for negative ground, positive ground or isolated electrical systems and are protected against reverse polarity hookup.

All models are powered by a 11-28 VDC battery and are reverse polarity protected.

Series Models

ATS Series Magnetic Sensor Signal Tach

50-304 flywheel teeth* 11-28 VDC, 3333 Hz to 20.27 kHz @ 4000 RPM

ATHS Series Magnetic Sensor Signal Tachometer/Hourmeter
50-304 flywheel teeth* 11-28 VDC, 3333 Hz to 20.27 kHz @ 4000 RPM

* To determine pulses per engine revolution, work the formulas on the back page and use the pulses per revolution number to determine if the tachometer can be used for your application.

ATA Series Alternator Signal Tachometer

3-40 pulses*/engine revolution 12 VDC, 200 Hz to 2667 Hz @ 4000 RPM

ATHA Series Alternator Signal Tachometer/Hourmeter

3-40 pulses*/engine revolution 12 VDC, 200 Hz to 2667 Hz @ 4000 RPM

ATHI Series Ignition Signal Tachometer/Hourmeter

2 - 10 cylinder, 4 cycle engines, 66.7 Hz to 333.3 Hz @ 4000 RPM

Bezel Styles

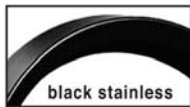

Applications

These tachometers are specially designed for use on truck, marine, industrial, or stationary engines.

Dimensions

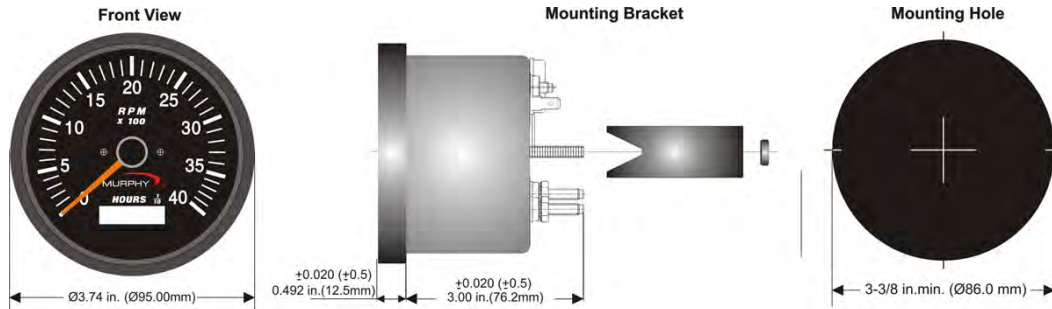

Specifications

Magnetic Sensor Driven Models

Power Input: 11-28VDC (70mA – 120mA except lamp load)

Backlight: 3.4W T-10 wedge base bulb

RPM Input Signal Voltage: 1.5Vrms minimum

Accuracy: Tachometer: +2% full scale
Hourmeter: +0.01% hours, +1 count

Temperature Range: -40°C to +82°C (no permanent damage shall occur)

Dial (Face Plate): 270° sweep with white numerals (over black background)

Bezel: 304 stainless steel for bright and IS 513 E.E.E. CRCA steel for black

Scale: 0-4000RPM

Case Material: Plastic

Hourmeter Range: 99999.9 hours in 0.1 increments.

Alternator Driven and Ignition Driven Models

Power Input: 11-28VDC (70mA-120mA except lamp load)

Backlight: 3.4W T-10 wedge base bulb

RPM Input Signal Voltage: V low: 0.5V max, V high: 8.0V min.

Accuracy: Tachometer: +2% full scale
Hourmeter: +0.01% hours, +1 count

Temperature Range: -40°C to +82°C (no permanent damage shall occur)

Dial (Face Plate): 270° sweep with white numerals (over black background)

Bezel: 304 stainless steel for bright and IS 513 E.E.E. CRCA steel for black

Scale: 0-4000RPM

Case Material: Plastic

Hourmeter Range: 99999.9 hours in 0.1 increments.

How to Order

Order the Tachometer or Tachometer/Hourmeter by model number.

Magnetic Sensor Tachometer 4000 RPM; 50 - 304 flywheel teeth 11-28 VDC

Model #	Designation
ATS-40	Bright Stainless Steel Bezel
ATS-40-A	Black Stainless Steel Bezel
ATS-40-B	SAE Bright Stainless Steel Bezel
ATS-40-C	SAE Black Stainless Steel Bezel

Magnetic Sensor Tach/Hourmeter 4000 RPM; 50-304 flywheel teeth 11-28 VDC

ATHS-40	Bright Stainless Steel Bezel
ATHS-40-A	Black Stainless Steel Bezel
ATHS-40-B	SAE Bright Stainless Steel Bezel
ATHS-40-C	SAE Black Stainless Steel Bezel

Alternator Signal Tachometer 4000 RPM; 3 - 40 pulses/rev 11-28 VDC

ATA-40	Bright Stainless Steel Bezel
ATA-40-A	Black Stainless Steel Bezel
ATA-40-B	SAE Bright Stainless Steel Bezel

Alternator Signal Tach/Hourmeter 4000 RPM; 3 - 40 pulses/rev 11-28 VDC

ATHA-40	Bright Stainless Steel Bezel
ATHA-40-A	Black Stainless Steel Bezel
ATHA-40-B	SAE Bright Stainless Steel Bezel
ATHA-40-C	SAE Black Stainless Steel Bezel

Ignition Signal Tach/Hourmeter 4000 RPM; 1-5 pulses/engine rev

ATHI-40-A	Black Stainless Steel Bezel
-----------	-----------------------------

FW MURPHY

5311 South 122nd East Avenue
Tulsa, Oklahoma 74146 USA
Phone: +1 918 317 4100 Fax: +1 918 317 4266
E-mail: sales@fwmurphy.com
Website: www.fwmurphy.com

ECONROLS, INC.

5757 Farinon Drive
San Antonio, Texas 78249 USA
Phone: +1 210 495 9772 Fax: +1 210 495 9791
E-mail: info@econrols.com
Website: www.econrols.com

FWM INDUSTRIAL PANEL DIVISION

5311 South 122nd East Avenue
Tulsa, Oklahoma 74146 USA
Phone: +1 918 317 4100 Fax: +1 918 317 4124
E-mail: ipd@fwmurphy.com
Website: www.fwmurphy.com

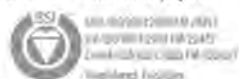

FRANK W. MURPHY, LTD.

Church Road, Laverstock
Salisbury, SP1 1GZ, UK
Phone: +44 1722 410055 Fax: +44 1722 410088
E-mail: sales@fwmurphy.co.uk
Website: www.fwmurphy.co.uk

FW MURPHY INSTRUMENTS (HANGZHOU) CO., LTD.

77 23rd Street
Hangzhou Economic & Technological Development Area
Hangzhou, Zhejiang, 310018, China
Phone: +86 571 8788 6060 Fax: +86 571 8684 8878
E-mail: aps@fwmurphy.com
Website: www.fwmurphy.com/company_ch

FW MURPHY (LATIN AMERICA & CARIBBEAN)

Apdo. Postal 2-06, Admon "Lomas"
Cord. Anekán 606-16, Lomas 4^a Secc.
78211 San Luis Potosí, S.L.P. - México
Phone: +1 918 317 2500
E-mail: lasales@fwmurphy.com
Website: www.fwmurphy.com

FW MURPHY (INDIA)

230, Ragus, Connaught Place Centre
Bund Garden Road, Pune 411001
Maharashtra State, India
Phone: +91 915 813 7633
E-mail: indiasales@fwmurphy.com
Website: www.fwmurphy.com

COMPUTRONIC CONTROLS

41 - 46 Railway Terrace
Nechells, Birmingham, B7 5NG, UK
Phone: +44 1722 410055
Fax: +44 1722 410088
E-mail: sales@computroniccontrols.com
Web site: www.computroniccontrols.com

