

**INDUSTRIAL DIESEL ENGINE**

**KUBOTA SUPER MINI SERIES (3-cylinder)**

# D902-E4B

**RATED POWER**

- **16.1kW @ 3200rpm**
- **18.5kW @ 3600rpm**

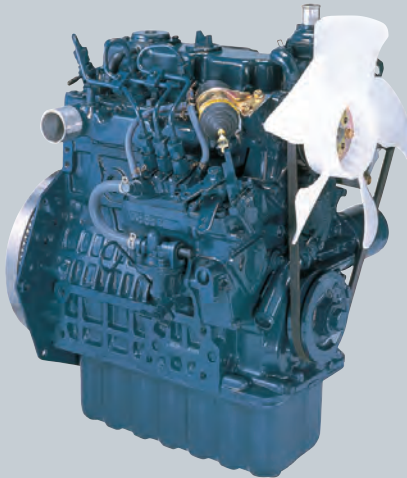

Photograph may show non-standard equipment.

**PERFORMANCE CURVE**

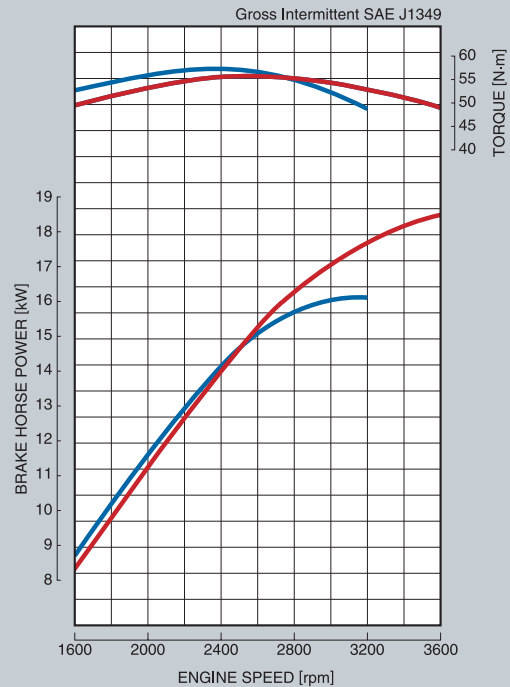

**FEATURES and BENEFITS**

**Emissions**

Kubota Super Mini Series, the most compact multi-cylinder liquid cooled industrial diesel engines, complies with EPA Tier 4 emissions regulations. These are the most stringent emissions regulations in the world in this class. Kubota engine less than 19kW meets emission standards over the NRTC and also meets the NTE requirements.

**Durable Power**

The D902 engine delivers the highest output within the Kubota Super Mini Series engines. By expanding the bore and stroke, Kubota increased engine displacement, while maintaining the same footprint as the D722 engine. By adopting an extended shallow oil pan, the engine height is lower than the D722 engine, providing a compact engine package. The cooling water passages between the cylinder bores, using Kubota's original casting technology as a countermeasure against heat load of high power density, provides both superior endurance and reliable engine characteristics. This engine offers a seamless transition from E3 to E4 by totally maintaining the same performance and physical characteristics of the previous E3 engines. Alternative fuel engines, WG972-G (Gasoline), WG972-L (LPG) and WG972-GL (Dual Fuel:Gasoline/LPG) are available with the same footprint as the D902 engine.

**Clean and Quiet Power**

Kubota's original E-TVCS (Three Vortex Combustion System) has been further improved for better emissions.

# KUBOTA SUPER MINI SERIES D902-E4B

## GENERAL SPECIFICATION

Model		D902-E4B	
Emission Regulation		Tier 4	
Type		Vertical 4-cycle Liquid Cooled Diesel	
Number of Cylinders		3	
Bore	mm (in)	72 (2.83)	
Stroke	mm (in)	73.6 (2.9)	
Displacement	L (cu.in)	0.898 (54.80)	
Combustion System		IDI	
Intake System		Naturally Aspirated	
Maximum Speed	rpm	3200	3600
Output: Gross Intermittent ( Industrial Use )	kW	16.1	18.5
	hp	21.6	24.8
	ps	21.9	25.2
Direction of Rotation		Counterclockwise Viewed on Flywheel	
Oil Pan Capacity	L (gal)	3.7 (0.98)	
Starter Capacity	V-kW	12-1.0	
Alternator Capacity	V-A	12-40	
Output: Stand-by ( Generator Use )	kW	16.6	
	hp	22.3	
	ps	22.6	
Output: Continuous ( Generator Use )	kW	15.2	
	hp	20.4	
	ps	20.7	
Length	mm (in)	467.1 (18.40)	
Width	mm (in)	420.5 (16.6)	
Height (1)	mm (in)	544.1 (21.42)	
Height (2)	mm (in)	204.0 (8.03)	
Dry Weight	kg (lb)	72.0 (158.8)	

## DIMENSIONS

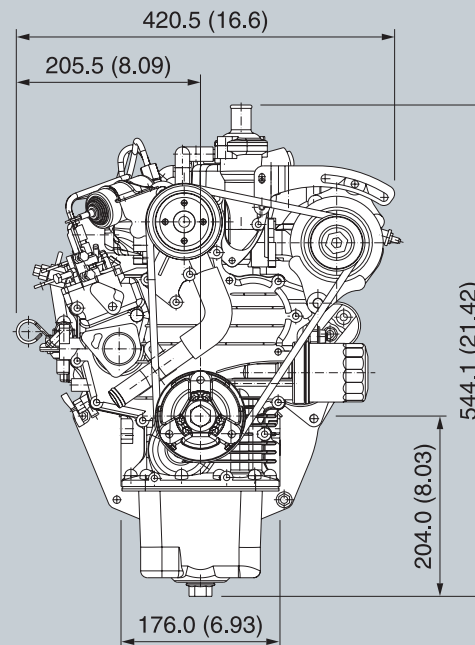
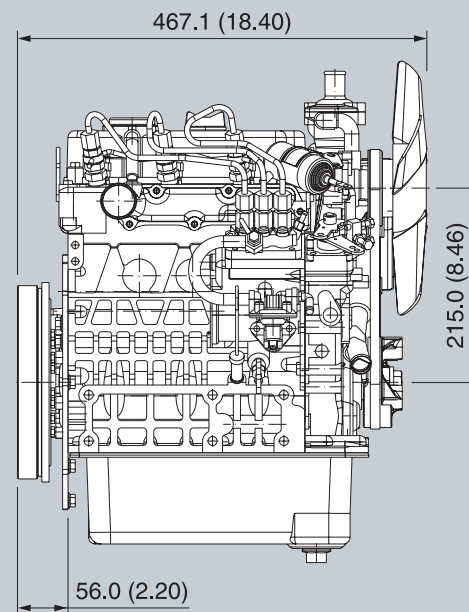

\*Specification is subject to change without notice.

\*Output: Gross Intermittent SAE J1995

\*Output: Stand-by, Continuous ISO 3046

\*Dry weight is according to Kubota's standard specification.

When specification varies, the weight will vary accordingly.



## KUBOTA Engine America Corporation

505 Schelton Road, Lincolnshire, IL 60069

Phone: 847-955-2500 Fax: 847-955-2699

[www.kubotaengine.com](http://www.kubotaengine.com)