

INDUSTRIAL DIESEL ENGINE

V3800-CR-TE4B V3800-TIE4B

KUBOTA V3 SERIES (4-cylinder)

RATED POWER

55.4kW @ 2200rpm



Photographs may show non-standard equipment.

PERFORMANCE CURVES

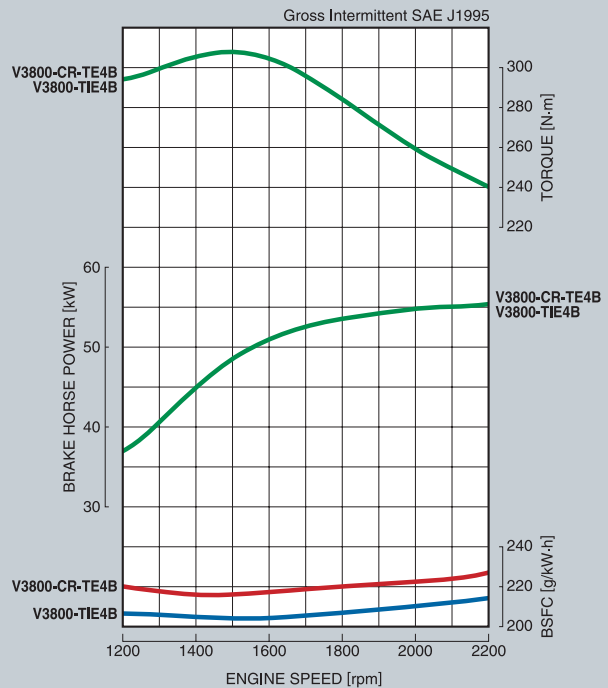

FEATURES and BENEFITS

Performance and Technology

Customers expect two things from Kubota: the strong performance and the latest technology.

We continue to provide both by seeking excellence in emissions compliance and new strides in fully electronic controlled engine. These key areas allow Kubota to offer flexibility in our products and services to customers worldwide.

Emission Compliance

Meeting rigid emission regulations can be a challenge for any company. At Kubota, our V3800-CR-TE4B and V3800-TIE4B engines have been designed to comply with the stringent regulations: The EPA/CARB Tier4 and the EU Stage IIIB. In addition, innovative emission solutions, such as an aftertreatment device, have also been integrated into the engine.

Clean and Quiet Power

The Common Rail System has made it possible to optimize combustion and create a more durable, quiet, and fuel efficient engine. The engine model is available with Diesel Oxidation Catalyst (DOC) only or Diesel Particulate Filter (DPF) + DOC aftertreatment.

Flexibility

When working with customers in different countries who have different engine requirements, flexibility is a must. Since Kubota's V3 Series engines have evolved step-by-step to meet every EPA Tier, we can provide the appropriate emission regulation certified engine to any customer worldwide. In addition, we have designed an aftertreatment device with minimum package impact for easy installation.

Reliability

The Kubota's V3 Series engines are the best solution for your company's global marketing strategy. We continuously strive to meet your needs with the experience and expertise you expect and deserve.

KUBOTA V3 SERIES V3800-CR-TE4B / V3800-TIE4B

GENERAL SPECIFICATIONS

Model		V3800-CR-TE4B	V3800-TIE4B
Emission Regulation		Tier4 / Stage III B	
Type		Vertical 4-cycle liquid cooled Diesel	
Number of Cylinders		4	
Bore	mm (in)	100.0 (3.937)	
Stroke	mm (in)	120.0 (4.724)	
Displacement	L (cu.in)	3.769 (230.0)	
Combustion System		DI	
Aspiration		Turbocharged	Turbocharged + Turbo After Cooler
Aftertreatment device		DOC + DPF	DOC
Rated Speed	rpm	2200	
Output: Gross Intermittent	kW	55.4	
	HP	74.3	
	ps	75.3	
Direction of Rotation		Counter clockwise viewed from flywheel side	
Oil Pan Capacity	L (U.S.gal)	13.2 (3.5)	
Starter Capacity	V-kW	12-3.0	
Alternator Capacity	V-A	12-100	
Length	mm (in)	889 (35.0)	
Width	mm (in)	581 (22.8)	
Height	mm (in)	851 (33.5)	
Dry Weight	kg (lb)	325 (717)	324 (714)

DIMENSIONS

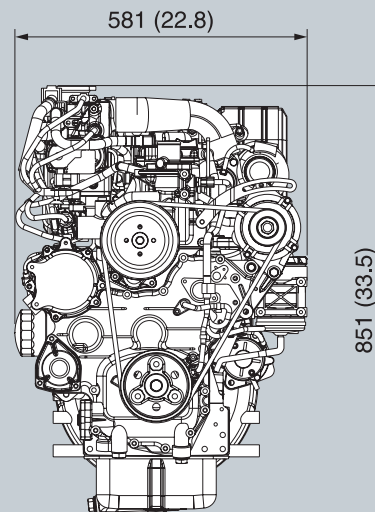
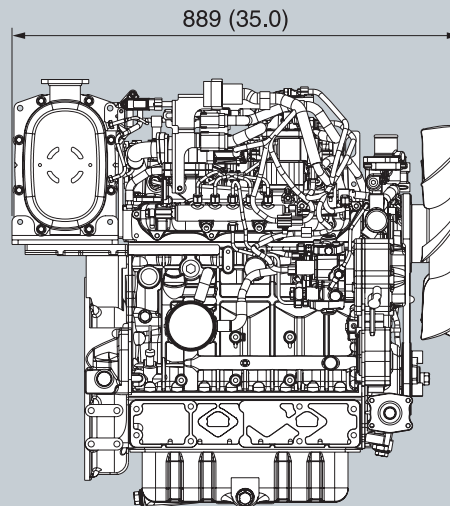

Dimensions and weight depend on composed specifications.

*Specification is subject to change without notice.

*Diesel Oxidation Catalyst (DOC)

*Diesel Particulate Filter (DPF)

*Output: Gross Intermittent SAE J1995

*Dimensions and weight are according to Kubota's standard specifications.



KUBOTA Engine America Corporation

505 Schelter Road, Lincolnshire, IL 60069

Phone: 847-955-2500 Fax: 847-955-2699

www.kubotaengine.com