

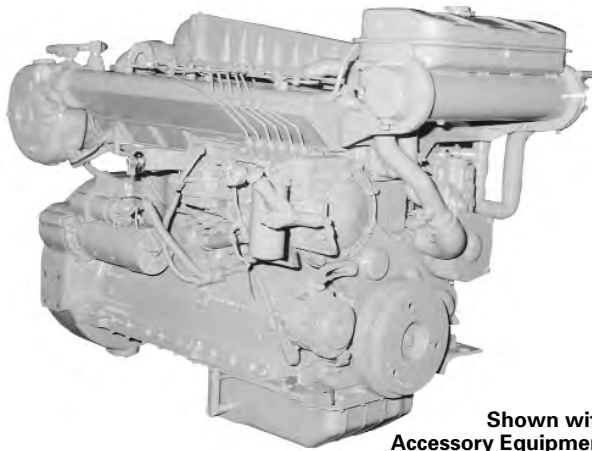

Marine Auxiliary Engine 3306B

102 bkW (137 bhp) 139 mhp @ 1200 rpm



Shown with Accessory Equipment

STANDARD EQUIPMENT

Air Inlet System

Regular duty air cleaner, rain cap

Charging System

24V 35 Amp alternator

Cooling System

Gear driven, self-priming, centrifugal auxiliary water pump with rubber impeller (heat exchanger engines); gear driven, centrifugal, jacket water pump; expansion tank; oil cooler; engine mounted heat exchanger with removable tube bundle and replaceable copper-nickel tubes (heat exchanger engines); thermostat and housing

Exhaust System

Watercooled manifold and turbocharger; dry elbow and flange, 127 mm (5 in.)

Flywheel and Flywheel Housing

SAE No. 1 (156 teeth)

Fuel System

Fuel priming pump, fuel transfer pump, fuel filter, primary fuel filter, flexible fuel lines

Instruments

RH instrument panel with oil pressure, water temperature, and fuel pressure gauges; service meter

Lube System

Top mounted crankcase breather, LH oil filter and oil level gauge, oil pan

Mounting System

Supports

Starting System

24V electric starting motor

General

Vibration damper and guard, Caterpillar yellow paint, lifting eyes

SPECIFICATIONS

I-6, 4-Stroke-Cycle-Diesel

Emissions IMO compliant
 Displacement 10.5 L (641 cu. in.)
 Bore 120.7 mm (4.75 in.)
 Stroke 152.4 mm (6.0 in.)
 Aspiration Turbocharged-Aftercooled
 Governor Hydra-mechanical or PSG
 Engine Weight, Net Dry (approx)
 Heat Exchanger Cooled 1027 kg (2265 lb)
 Capacity for Liquids
 Cooling System (engine only) 15.9 L (4.2 U.S. gal)
 Lube Oil System 38.8 L (10.25 U.S. gal)
 Oil Change Interval 250 hr
 Caterpillar DEO 10W30 or 15W40
 Rotation (from flywheel end) Counterclockwise

ACCESSORY EQUIPMENT

Air Starting Motor
 Alarm Contactor — Oil Pressure, Water Temperature
 24V 35 Amp, 24V 60 Amp Alternator
 Auxiliary Drive Pulley
 Digital Tachometer
 Double Wall Fuel Lines and Drain
 12V Electric Gauges — Oil Pressure, Water Temperature
 24V or 32V Electric Gauges — Oil Pressure, Water Temperature
 Electric Shutoffs — Oil Pressure, Water Temperature, Overspeed
 Ether Starting Aid
 Exhaust Elbow, Pipe, Flexible Fittings
 Fuel Ratio Control
 Generator Installation Arrangement
 Hydraulic Pump Drive and Adapter
 Magnetic Pickup
 Manual Shutoff Lever
 Manual Voltage Control
 Mechanical Tachometer Drive
 Mechanical Overspeed Contactor
 Paralleling Kit
 Rear Enclosed Clutch and Support
 RFI Filter
 RH Oil Level Gauge
 Solenoid Shutoff — 12V or 24V, ETR or ETS
 Spare Parts Kit

PERFORMANCE DATA

Turbocharged-Aftercooled

DM0676-00

102 bkW (.8 pf) 137 bhp			
% load	bkW	Lph	gph
100	96	30.4	8.0
75	75	23.9	6.3
50	50	16.7	4.4
25	26	10.3	2.7

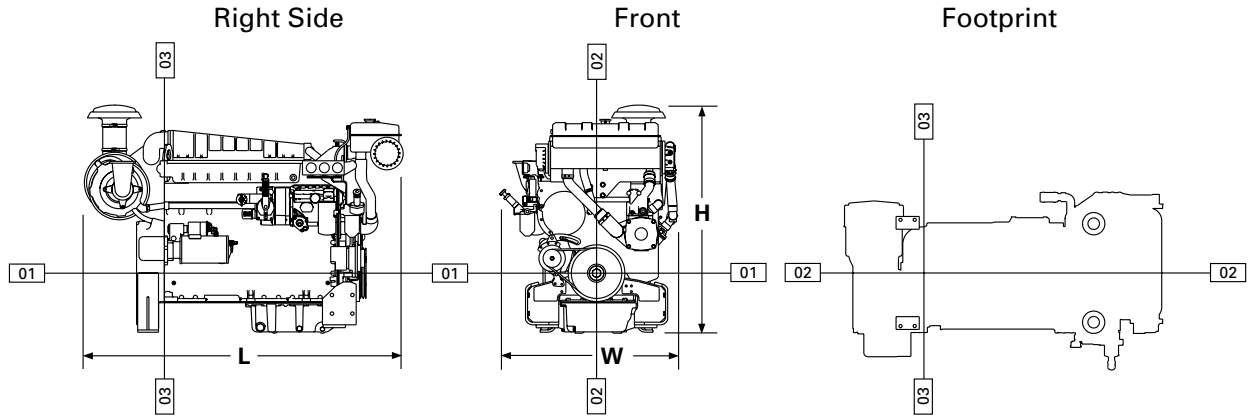

DIMENSIONS*

	mm	in.		mm	in.
Overall Length	1715.6	67.5			
Length from front to rear face of block	1285.0	50.6			
Length from rear face of block to back of flywheel housing	149.8	5.9			
Overall Height	1227.2	48.3			
Height from crankshaft centerline to top of engine	904.4	35.6			
Height from crankshaft centerline to bottom of oil pan	322.8	12.7			
Overall Width	956.7	37.7			
Width from crankshaft centerline to port side (left side)	434.8	17.1			
Width from crankshaft centerline to starboard side (right side)	521.9	20.6			
			Front	Rear	
Customer mounting hole diameter	62.0	2.4	mm	mm	in.
Width from crankshaft centerline to side	265.1	10.4	in.	in.	in.
Length from rear face of block to mounting hole	913.9	36.0		285.8	11.3
				49.5	2.0
				125.7	5.0

*Illustrations and dimensions from drawing: 118-7822.

RATING CONDITIONS

Engine Performance Parameters

Power.....	±3%
Specific Fuel Consumption	±3%
Fuel Rate	±5%

Ratings are based on SAE J1228/ISO8665 standard conditions of 100 kPa (29.61 in. Hg), 25°C (77°F), and 30% relative humidity. These ratings also apply at ISO3046/1, DIN6271/3, and BS5514 conditions of 100 kPa (29.61 in. Hg), 27°C (81°F), and 60% relative humidity.

Fuel rates are based on fuel oil of 35° API [16°C (60°F)] gravity having an LHV of 42 780 kJ/kg (18,390 Btu/lb) when used at 29°C (85°F) and weighing 838.9 g/L (7.001 lb/U.S. gal).

Additional ratings may be available for specific customer requirements. Consult your Caterpillar representative for additional information.

Performance data is calculated in accordance with tolerances and conditions stated in this specification sheet and is only intended for purposes of comparison with other manufacturers' engines. Actual engine performance may vary according to the particular application of the engine and operating conditions beyond Caterpillar's control.

TMI Reference No.: DM0676-00 (6-15-01)

Materials and specifications are subject to change without notice.

The International System of Units (SI) is used in this publication.

LEHM1567-00 (6-01)

Supersedes LEHM5611

Printed in U.S.A.

©2001 Caterpillar
All rights reserved.